

HP Ethernet MCU card with STM32F407VGT6 (100-pin TQFP)

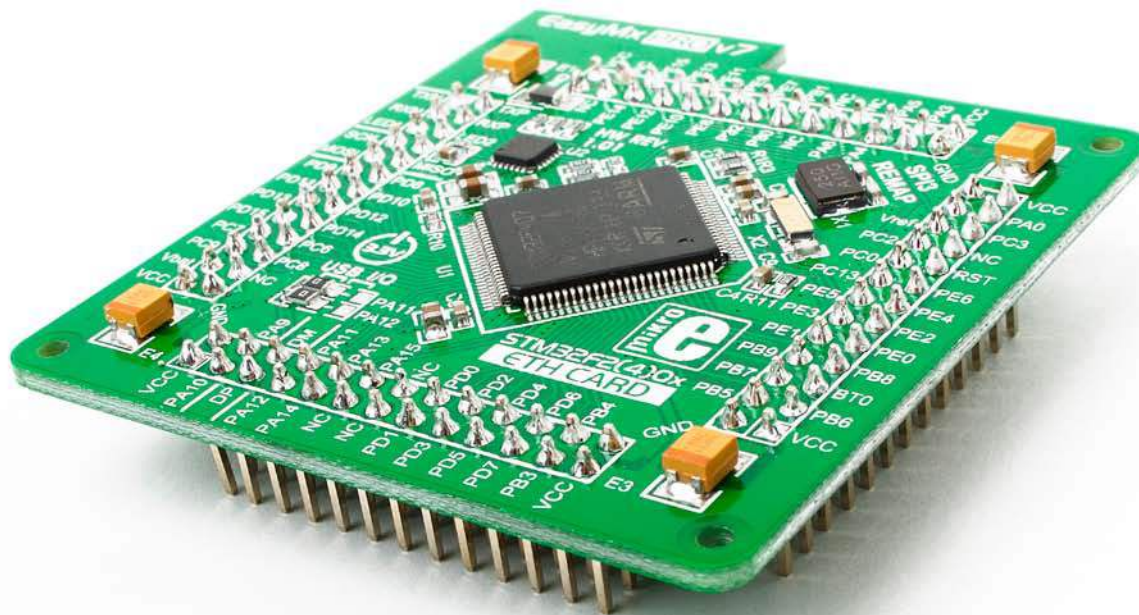

Card information

The **HP ETH MCU card** is shown on **Figure 1**. It contains **STM32F407VGT6** microcontroller with on-chip peripherals and is a great choice for both beginners and professionals. After testing and building the final program, this card can also be taken out of the board socket and used in your final device.

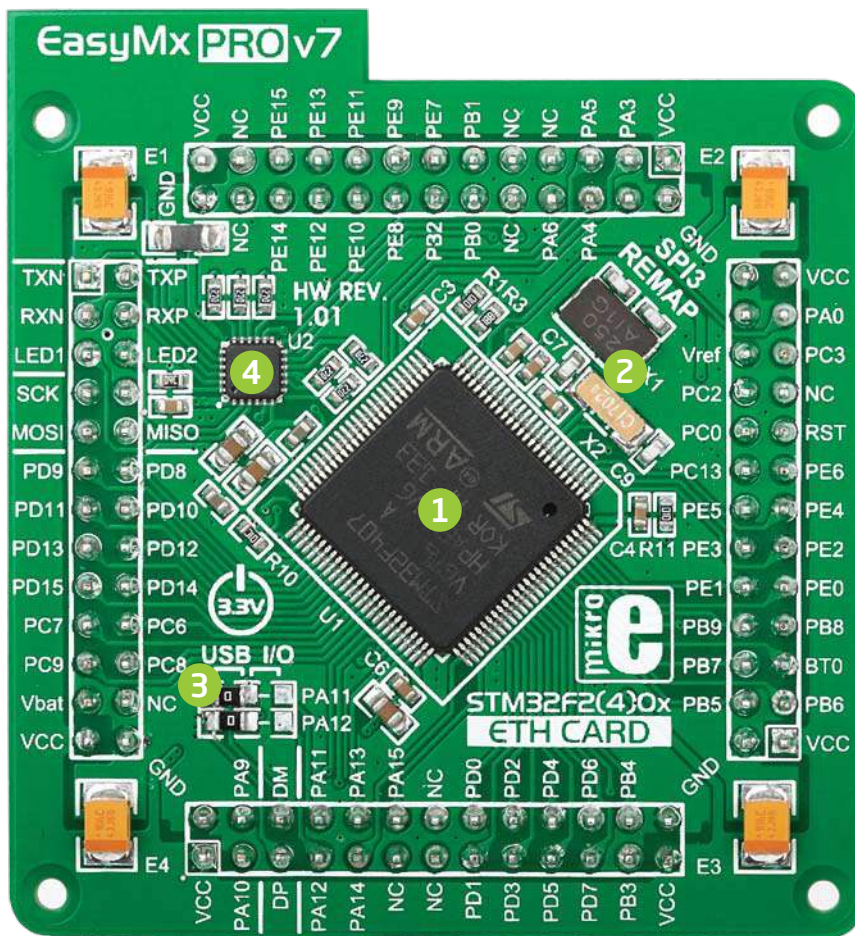

Figure 1: MCU card with STM32F407VGT6

- 1 **STM32F407VGT6** chip has **168MHz** frequency, **1 Mbyte** of Flash memory, **192K + 4K bytes** of general-purpose SRAM, integrated Ethernet controller, **USB 2.0** (OTG, Host, Device), 83 General purpose **I/O pins**, 12x16-bit and 2x32-bit **timers**, 3x12-bit **A/D** (24 channels), 2x12-bit **D/A**, 4x**USARTs**, 2x**UARTs**, Real time clock (**RTC**), 2x**I2C**, 3x**SPI** and 2x**CAN** controllers.
- 2 **25MHz crystal oscillator**. We carefully chose the most convenient crystal value that provides clock frequency which can be used directly, or with the PLL multipliers to create higher MCU clock value. MCU card also contains 32.768 kHz crystal oscillator which provides external clock for RTCC module.
- 3 **USB communications lines**. These two jumpers, when in USB position, connect D+ and D- lines of the on-board USB connector with PA11 and PA12 microcontroller pins. Since **STM32F407VGT6** supports USB, jumpers are in USB position.
- 4 **Ethernet transceiver**. MCU card contains single-chip Ethernet physical (PHY) layer transceiver which provides additional Ethernet functionality to **STM32F407VGT6** controller

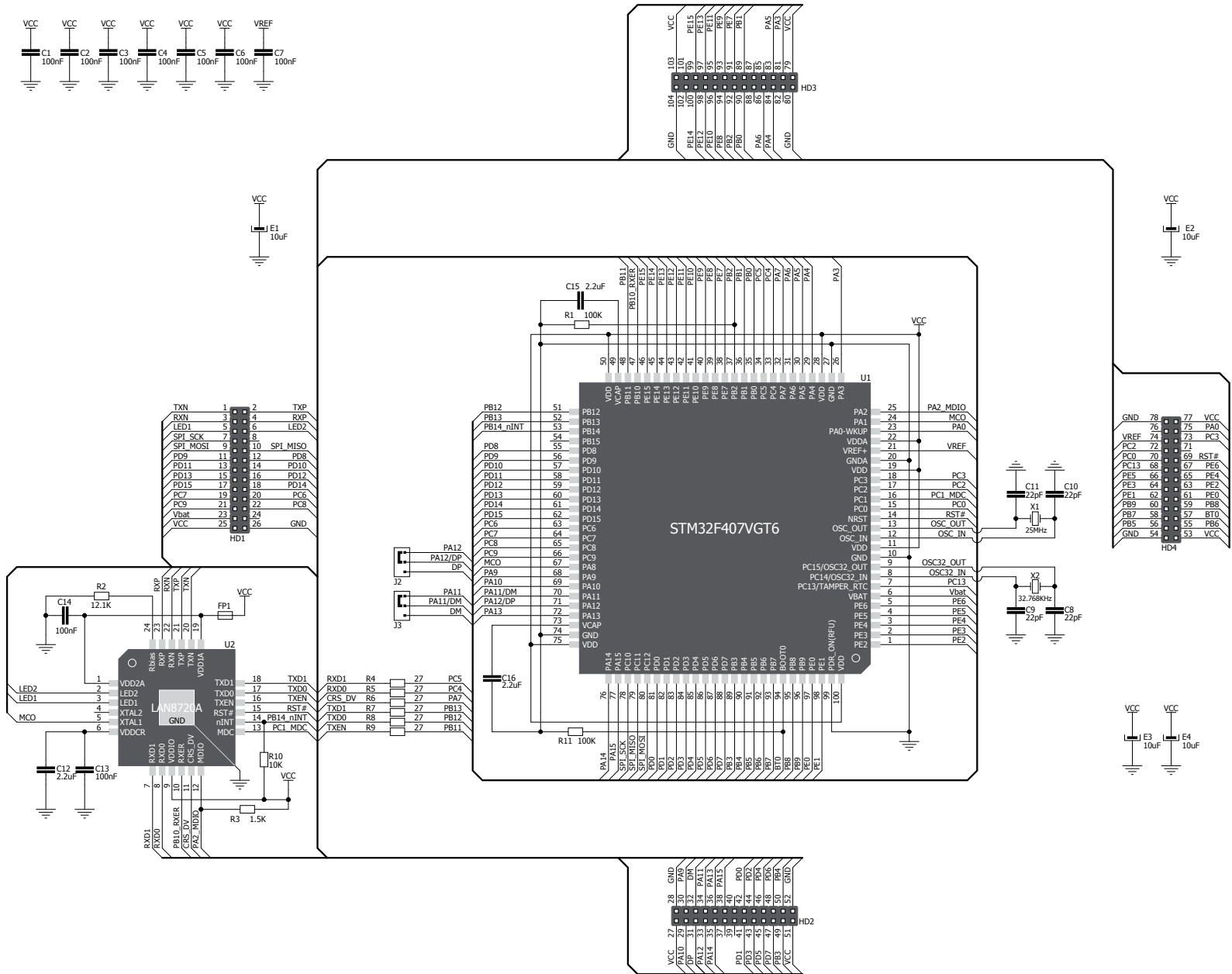

Figure 2: MCU card schematics

Card dimensions

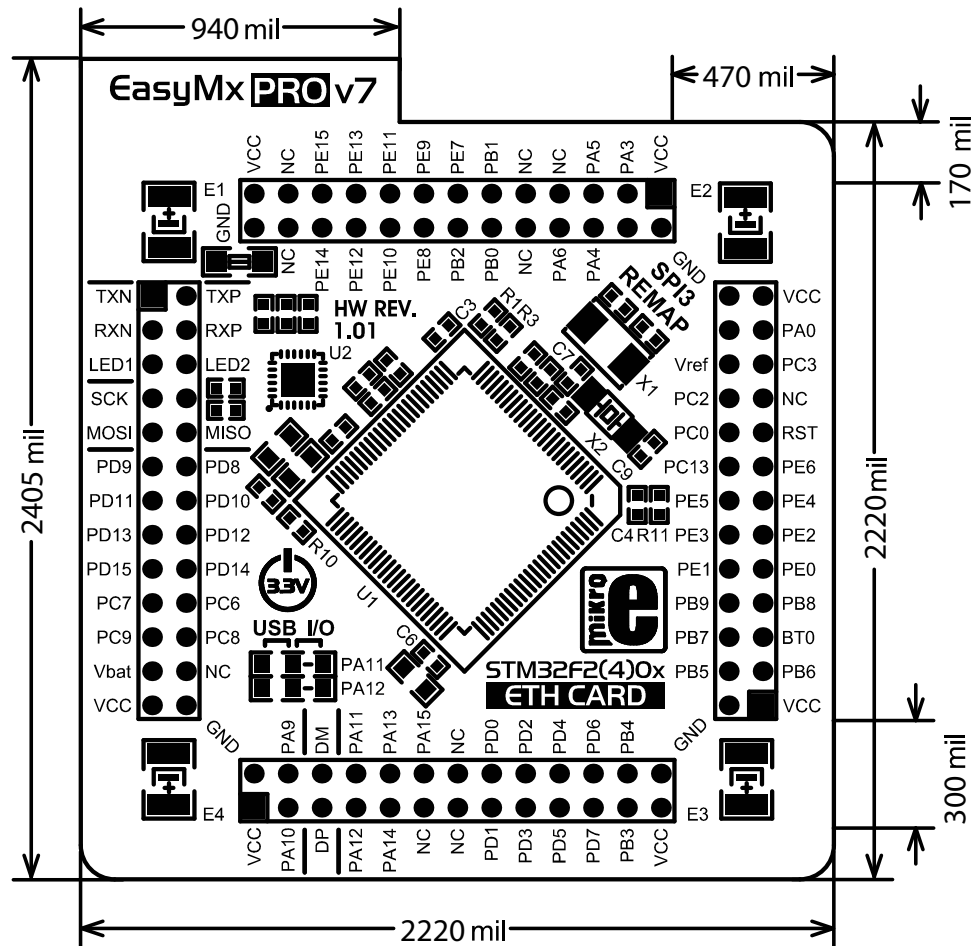

Figure 3: MCU card dimensions. Values are in mils.



If you want to learn more about our products, please visit our web site at www.mikroe.com

If you are experiencing some problems with any of our products or just need additional information, please place your ticket at www.mikroe.com/esupport

If you have any questions, comments or business proposals, do not hesitate to contact us at office@mikroe.com