

NOTES:

1. MATERIALS AND FINISHES:  
 BODY - BRASS, GOLD PLATING  
 CONTACT - BRASS, GOLD PLATING  
 INSULATOR - PTFE
2. ELECTRICAL:  
 A. IMPEDANCE: 50 OHM  
 B. DIELECTRIC WITHSTANDING VOLTAGE: 1000 VRMS, MIN.
3. MECHANICAL:  
 A. DURABILITY: 500 CYCLES MIN.  
 B. TEMPERATURE RANGE: -65° C TO +165° C
4. PACKAGING:  
 A. QUANTITY: SINGLE PACK  
 B. MARKING: BAG TO BE MARKED  
 "AMPHENOL RF, 901-155-16, AND DATE CODE"
5. SHOWS CABLE ENTRY DIMENSIONS.
6. FOR CABLE ASSEMBLY INSTRUCTIONS, SEE SHEET 17 OF AMPHENOL SPEC 349-50114.

901-155-16		REVISIONS			
DRAWING NO.	REV	DESCRIPTION	DATE	ECO	APPR
THIRD ANGLE PROJ.	--	RELEASE TO MFG.	--	--	
	J	REDRAWN IN PRO-E, ADD COD	7/14/11	48601	BM
	K	ADD STAMPING TO COD	11/15/11	48803	CPM

# MIL-C-39012 INSPECTION

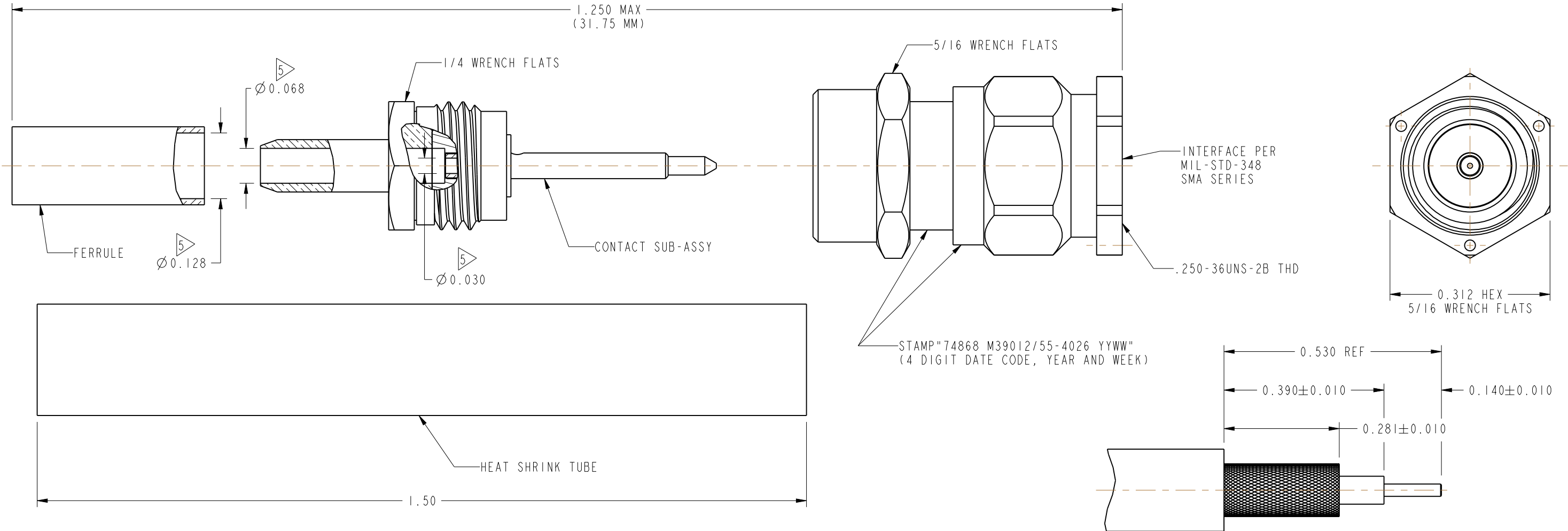
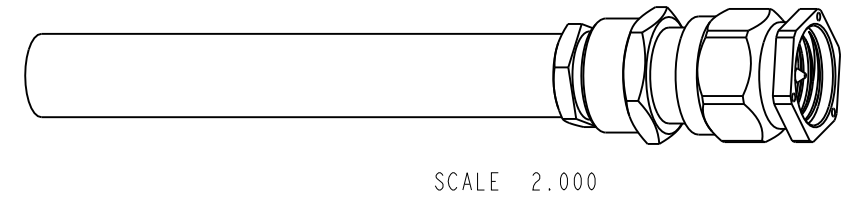

## RECOMMENDED CABLE STRIPPING DIMENSIONS

## CUSTOMER OUTLINE DRAWING

ALL OTHER SHEETS ARE FOR INTERNAL USE ONLY

UNLESS OTHERWISE SPECIFIED, DIMENSIONS ARE IN INCHES AND TOLERANCES ARE: 2 PLACE DECIMAL ±.015 (0,381 mm) 3 PLACE DECIMAL ±.005 (0,127 mm) ANGLES ± 1°	MATERIAL SEE NOTES	DRAWN BALAJI M	DATE 22-Jun-09	TITLE SMA STR PLUG CRIMP TYPE FOR RG-174/U & RG-316/U CABLES	Amphenol RF Danbury, CT, USA Tainan, Taiwan Shenzhen, China www.amphenolrf.com
	REFERENCE DOR 313050-51 MIL-C-39012/55-4026	ENGINEER	DATE		
NOTICE - These drawings, specifications, or other data (1) are, and remain the property of Amphenol Corp. (2) must be returned upon request; and (3) are confidential and not to be disclosed to any person other than those to whom they are given by Amphenol Corp. The furnishing of these drawings, specifications, or other data by Amphenol Corp., or to any other person to anyone for any purpose is not to be regarded by implication or otherwise in any manner licensing, granting rights or permitting such holder or any other person to manufacture, use or sell any product, process or design, patented or otherwise, that may in any way be related to or disclosed by said drawings, specifications, or other data.	APPROVED K. CAPOZZI	DATE 6/30/11	CODE ID 74868	DWG SIZE B	DRAWING NO. 901-155-16
	CAD FILE Root Folder/SMA/901-155-16	SCALE: 5.0:1	SHEET 2 OF 2	REV K	