

REVISION D

DO NOT SCALE FROM THIS PRINT

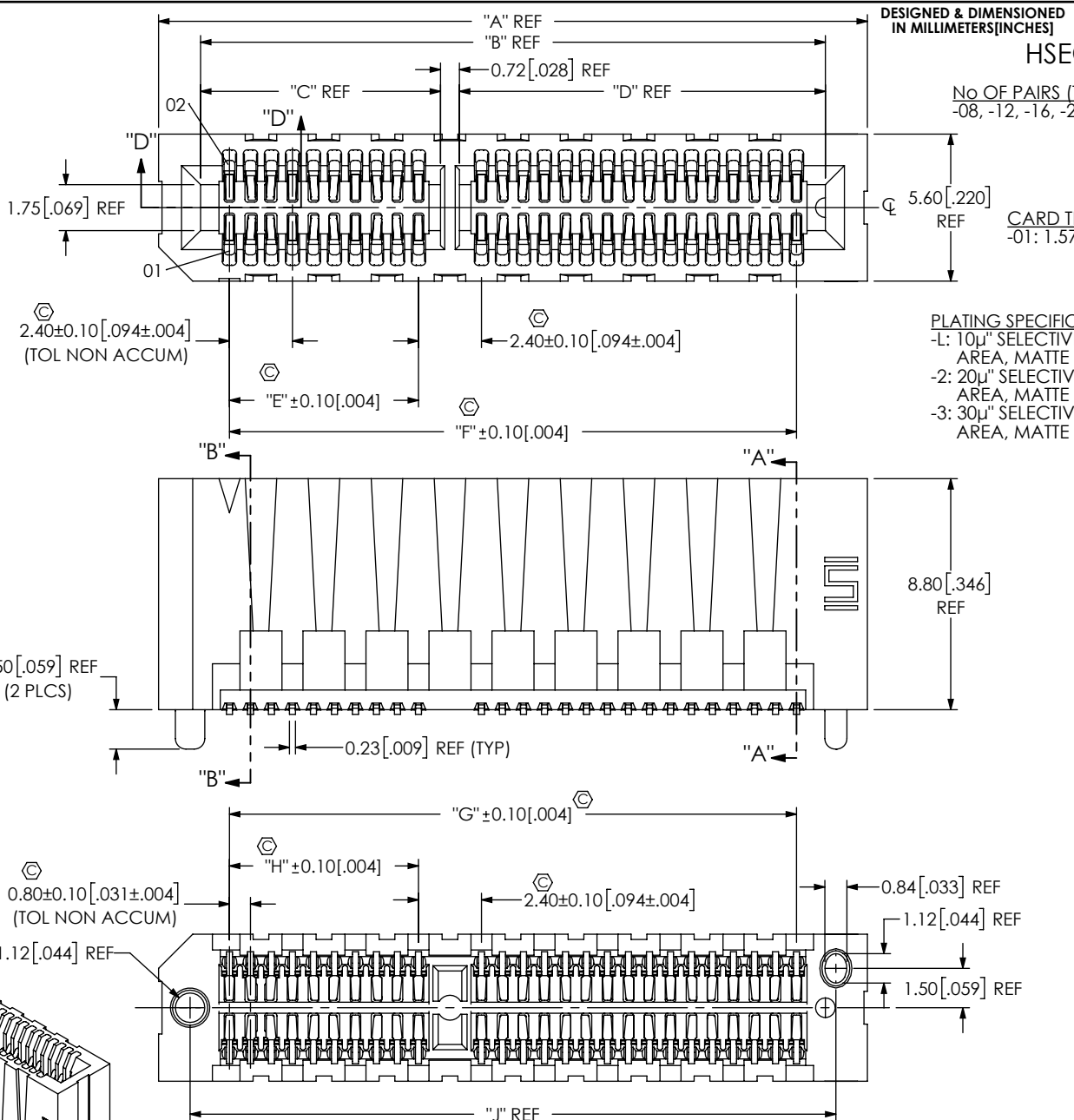

TABLE 1

No OF PAIRS	"A"	"B"	"C"
-08	17.40 [0.685]	14.20 [0.559]	4.34 [0.171]
-12	22.20 [0.874]	19.00 [0.748]	6.74 [0.265]
-16	27.00 [1.063]	23.80 [0.937]	9.14 [0.360]
-20	31.80 [1.252]	28.60 [1.126]	11.54 [0.454]
-32	46.20 [1.819]	43.00 [1.693]	18.74 [0.738]
-56	75.00 [2.953]	71.80 [2.827]	33.14 [1.305]

No OF PAIRS	"D"	"E"	"F"
-08	9.14 [0.360]	2.40 [0.094]	12.00 [0.472]
-12	11.54 [0.454]	4.80 [0.189]	16.80 [0.661]
-16	13.94 [0.549]	7.20 [0.283]	21.60 [0.850]
-20	16.34 [0.643]	9.60 [0.378]	26.40 [1.039]
-32	23.54 [0.927]	16.80 [0.661]	40.80 [1.606]
-56	37.94 [1.494]	31.20 [1.228]	69.60 [2.740]

No OF PAIRS	"G"	"H"	"J"
-08	12.00 [0.472]	2.40 [0.094]	15.00 [0.591]
-12	16.80 [0.661]	4.80 [0.189]	19.80 [0.780]
-16	21.60 [0.850]	7.20 [0.283]	24.60 [0.969]
-20	26.40 [1.039]	9.60 [0.378]	29.40 [1.157]
-32	40.80 [1.606]	16.80 [0.661]	43.80 [1.724]
-56	69.60 [2.740]	31.20 [1.228]	72.60 [2.858]

- FIG 1
HSEC8-116-01-X-DP-A SHOWN (SOME FEATURES NOT SHOWN FOR CLARITY)
- NOTES:
- ⊕ REPRESENTS A CRITICAL DIMENSION.
 - MINIMUM PUSHOUT FORCE: 2.2 NEWTONS.
 - DIMENSIONS MEASURED TIP TO TIP.
 - SEE SAMTEC FOOTPRINT FOR MATING CARD SPECIFICATIONS.
 - TAPE & REEL IS STANDARD PACKAGING.
 - NOTE DELETED
 - K-DOT PROVIDED AS STANDARD.
 - ORDERS WILL BE PACKAGED ACCORDING TO THE SAMTEC PACKAGING EFFICIENCY STANDARDS (SPES) FOUND ON WWW.SAMTEC.COM
 - ATTACH LABEL TO EACH REEL

UNLESS OTHERWISE SPECIFIED, DIMENSIONS ARE IN MILLIMETERS. TOLERANCES ARE:

DECIMALS ANGLES
X.X: ±0.3 [01] 2°
X.XX: ±0.13 [005]
X.XXX: ±0.051 [0020]

PROPRIETARY NOTE
THIS DOCUMENT CONTAINS CONFIDENTIAL AND PROPRIETARY INFORMATION AND ALL DESIGN, MANUFACTURING, REPRODUCTION, USE, PATENT RIGHTS AND SALES RIGHTS ARE EXPRESSLY RESERVED BY SAMTEC, INC. THIS DOCUMENT SHALL NOT BE DISCLOSED, IN WHOLE OR PART, TO ANY UNAUTHORIZED PERSON OR ENTITY NOR REPRODUCED, TRANSFERRED OR INCORPORATED IN ANY OTHER PROJECT IN ANY MANNER WITHOUT THE EXPRESS WRITTEN CONSENT OF SAMTEC, INC.

MATERIAL: DO NOT SCALE DRAWING SHEET SCALE: 4:1
INSULATOR: LCP, UL 94 V0, COLOR: BLACK
CONTACT: COPPER ALLOY
WELD TAB: BRASS ALLOY

DESCRIPTION:
0.8MM DIFF PAIR EDGE CARD ASSEMBLY

DWG. NO.
HSEC8-1XX-XX-X-DP-A-XX-K-XX

BY: JESSIE W 8/23/2016 SHEET 1 OF 3

F:\DWG\MISC\MKTG\HSEC8-1XX-XX-X-DP-A-XX-K-XX-MKT.SLDDRW



520 PARK EAST BLVD, NEW ALBANY, IN 47150
PHONE: 812-944-6733 FAX: 812-948-5047
e-Mail: info@SAMTEC.com code 53322

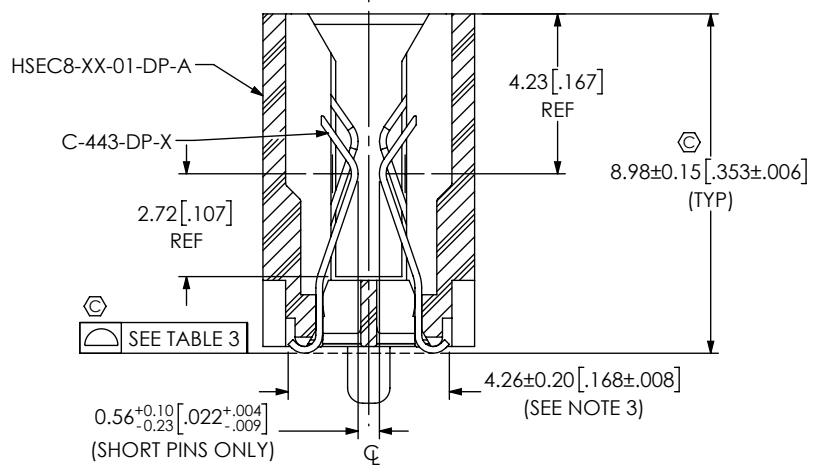

SECTION "A"-"A"
SCALE 5 : 1

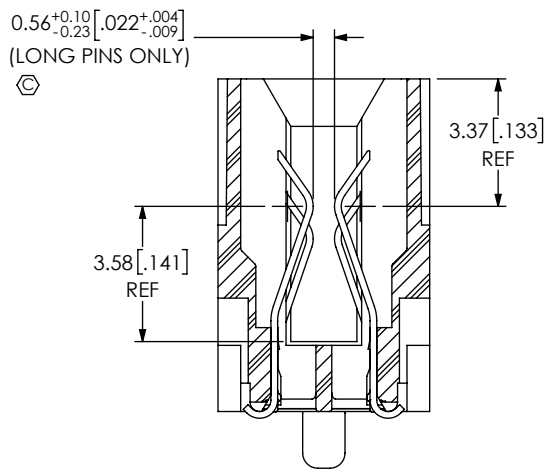

SECTION "B"-"B"
SCALE 5 : 1
(DIFFERENT AS SHOWN, OTHERWISE SAME AS SECTION "A"-"A")

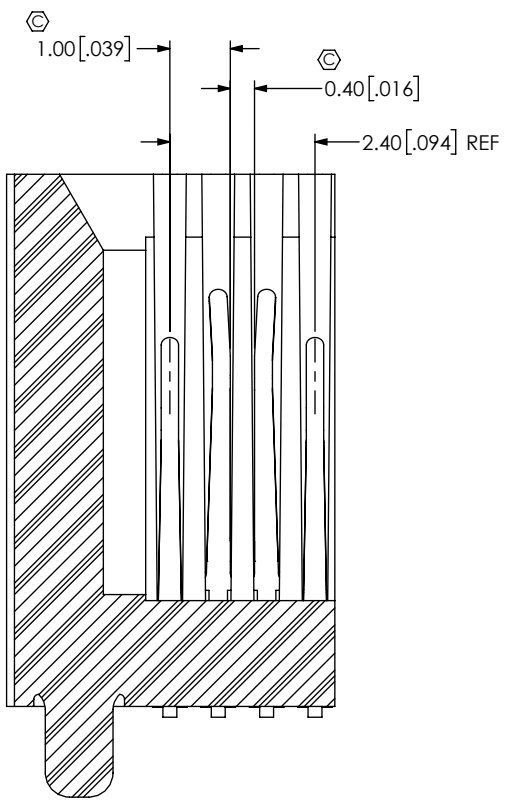

SECTION "D"-"D"
SCALE 8 : 1

TABLE 3	
No OF PAIRS	COPLANARITY
-08 THRU -32	0.10 [.004]
-56	0.15 [.006]

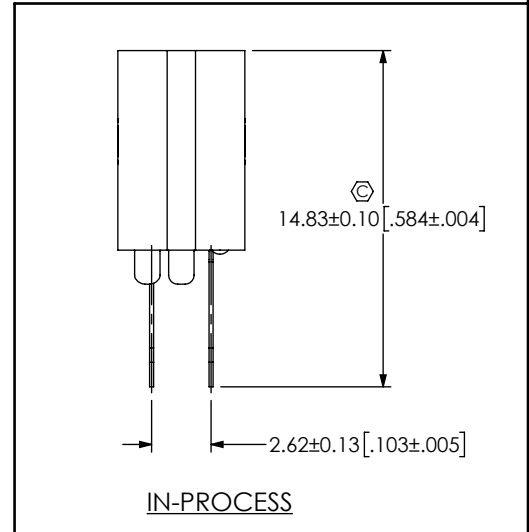

IN-PROCESS

PROPRIETARY NOTE
THIS DOCUMENT CONTAINS CONFIDENTIAL AND PROPRIETARY INFORMATION AND ALL DESIGN, MANUFACTURING, REPRODUCTION, USE, PATENT RIGHTS AND SALES RIGHTS ARE EXPRESSLY RESERVED BY SAMTEC, INC. THIS DOCUMENT SHALL NOT BE DISCLOSED, IN WHOLE OR PART, TO ANY UNAUTHORIZED PERSON OR ENTITY NOR REPRODUCED, TRANSFERRED OR INCORPORATED IN ANY OTHER PROJECT IN ANY MANNER WITHOUT THE EXPRESS WRITTEN CONSENT OF SAMTEC, INC.



520 PARK EAST BLVD, NEW ALBANY, IN 47150
PHONE: 812-944-6733 FAX: 812-948-5047
e-Mail: info@SAMTEC.com code 55322

DO NOT SCALE DRAWING
SHEET SCALE: 3:1

DESCRIPTION:
0.8MM DIFF PAIR EDGE CARD ASSEMBLY

DWG. NO.
HSEC8-1XX-XX-X-DP-A-XX-K-XX

BY: JESSIE W 8/23/2016 SHEET 2 OF 3

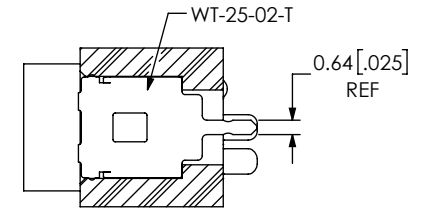
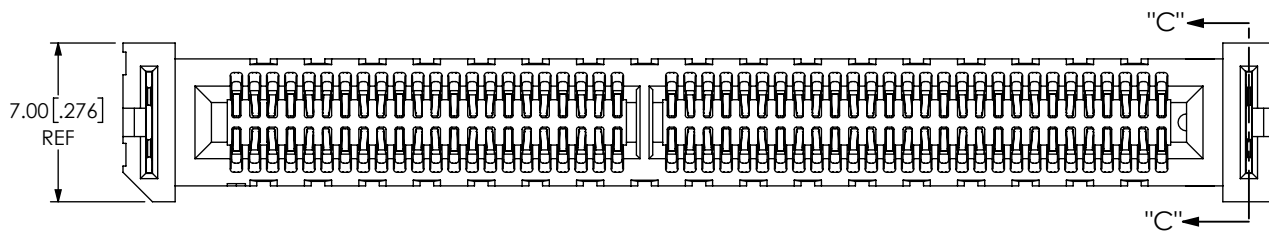

SECTION "C"- "C"

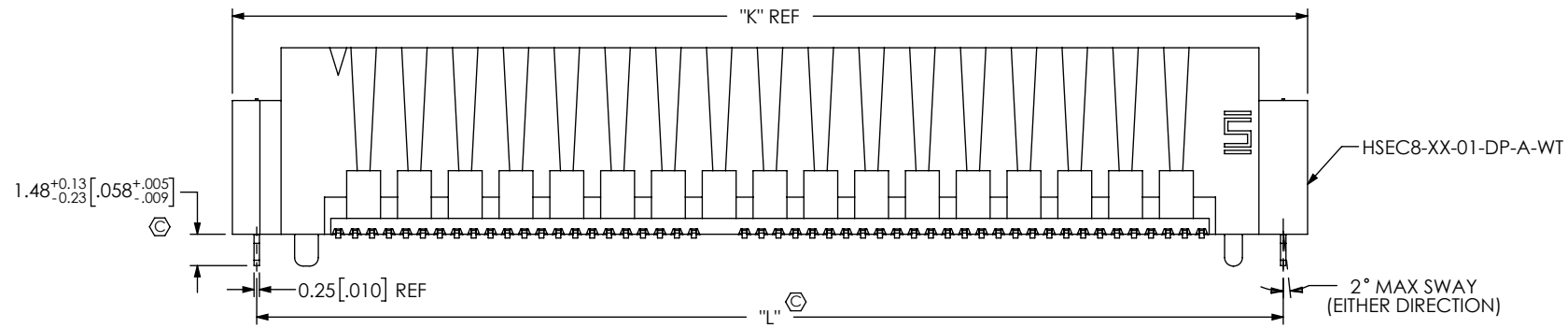

FIG 2
HSEC8-132-01-X-DP-A-WT SHOWN
(DIFFERENT AS SHOWN, OTHERWISE SAME AS FIG 1)

TABLE 2

No OF PAIRS	"K"	"L"	"M" (-A OPTION)	"M" (-WT OPTION)
-08	22.00 [.866]	19.70 [.776]	5.58 [.220]	7.88 [.310]
-12	26.80 [1.055]	24.50 [.965]	7.98 [.314]	10.28 [.405]
-16	31.60 [1.244]	29.30 [1.154]	10.38 [.409]	12.68 [.499]
-20	36.40 [1.433]	34.10 [1.343]	12.78 [.503]	15.08 [.594]
-32	50.80 [2.000]	48.50 [1.909]	19.98 [.787]	22.28 [.877]
-56	79.60 [3.134]	77.30 [3.043]	34.38 [1.354]	36.68 [1.444]

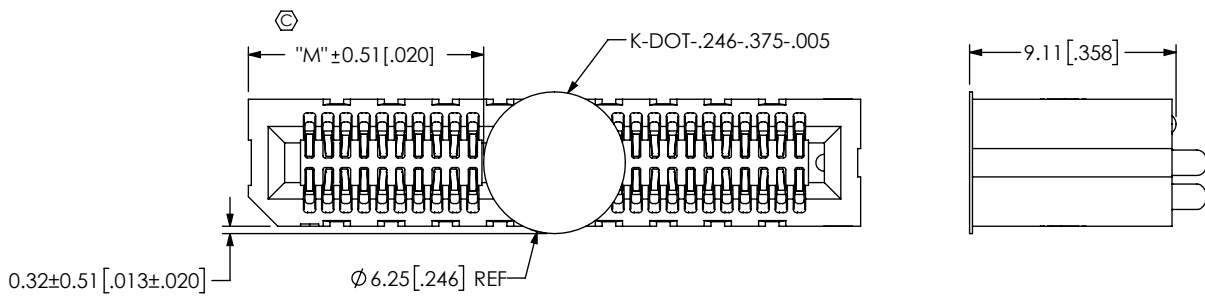

FIG 3
HSEC8-116-01-X-DP-A SHOWN WITH K-DOT
(DIFFERENT AS SHOWN, OTHERWISE SAME AS FIG 1)

PROPRIETARY NOTE

THIS DOCUMENT CONTAINS CONFIDENTIAL AND PROPRIETARY INFORMATION AND ALL DESIGN, MANUFACTURING, REPRODUCTION, USE, PATENT RIGHTS AND SALES RIGHTS ARE EXPRESSLY RESERVED BY SAMTEC, INC. THIS DOCUMENT SHALL NOT BE DISCLOSED, IN WHOLE OR PART, TO ANY UNAUTHORIZED PERSON OR ENTITY NOR REPRODUCED, TRANSFERRED OR INCORPORATED IN ANY OTHER PROJECT IN ANY MANNER WITHOUT THE EXPRESS WRITTEN CONSENT OF SAMTEC, INC.

samtec

520 PARK EAST BLVD, NEW ALBANY, IN 47150
PHONE: 812-944-6733 FAX: 812-948-5047
e-Mail: info@SAMTEC.com code 55322

DO NOT SCALE DRAWING

SHEET SCALE: 3:1

DESCRIPTION:
0.8MM DIFF PAIR EDGE CARD ASSEMBLY

DWG. NO.
HSEC8-1XX-XX-X-DP-A-XX-K-XX

BY: JESSIE W 8/23/2016 SHEET 3 OF 3