

Accessories

MK-923

RASPBERRY PI COMPUTE MODULE HEATSINK ACCESSORY

Compatible with Raspberry Pi Modules*

Dimensions = 90(l)x 75(w)x 10(h) mm
3.5(l)x 3(w)x 0.4(h) inches

Weight = 0.01 kg, 0.35 ounces

Includes: 2x M1.6 & 2x M2.0 screws and nuts, spare heatpad, and heatsink

This aluminium heatsink sits in direct contact with the Raspberry Pi compute module's integrated processing chip (SoC). The surface area of the heatsink is maximised to most efficiently utilise thermal conduction and draw heat away from the processor. Used by Brainboxes in the BB-400 and BB-411.

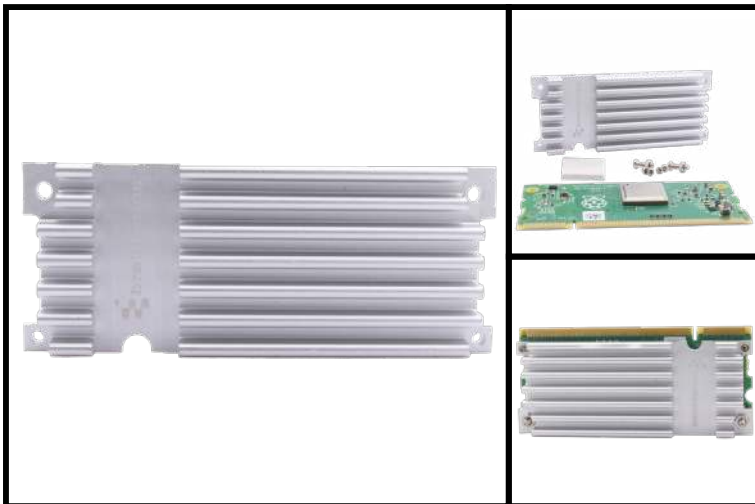

Type: Board Level

Mounting Configuration: Screw On 2xM2.0 + 2xM1.6 (Included)

Power Dissipation @ Temp. Rise: 2W @ 40°C

Thermal Resistance Forced Air Flow: 6.9°C/W @ 300LFM (1.5m/s)

Thermal Resistance Natural: 20.2°C/W

Material: Aluminium

Finish: Silver

Height above PCB: 8.7mm

*Rasp Pi not included.

Compatible with Raspberry Pi Compute Modules (CM):

- CM 3+
- CM3 Lite, CM3 and CM1 (use additional included thermal pad)

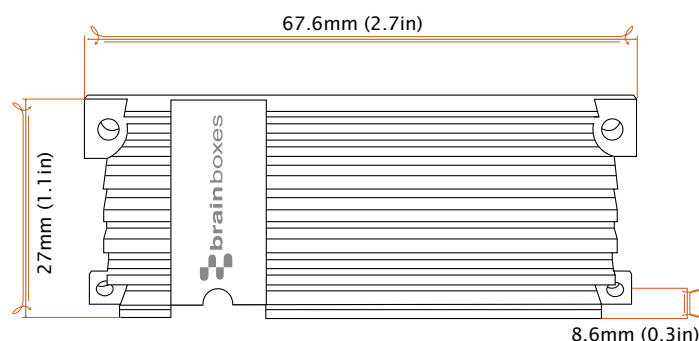
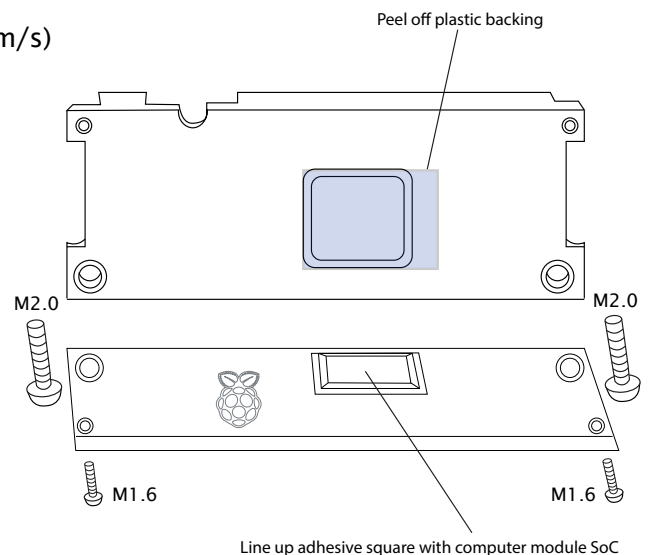

THERMAL RESISTANCE GRAPH

