

Evaluating the **AD4112** with ± 10 V and 0 mA to 20 mA Inputs and Integrated Analog Front End for Industrial Automation Systems

FEATURES

- Fully featured evaluation board for the **AD4112**
- PC control in conjunction with **SDP-B** system demonstration platform (**EVAL-SDP-CB1Z**)
- PC software for control and data analysis (time domain)

EVALUATION KIT CONTENTS

- EVAL-AD4112SDZ evaluation board
- AD411X Eval+ evaluation software

EQUIPMENT NEEDED

- EVAL-SDP-CB1Z** system demonstration platform
- DC signal source
- PC running Windows® with USB 2.0 port

GENERAL DESCRIPTION

The EVAL-AD4112SDZ is a full featured evaluation board that can be used to evaluate all the features of the **AD4112**. The **AD4112** is a 24-bit, 31.25 kSPS analog-to-digital converter (ADC) with a ± 10 V input voltage range (eight single-ended channels or four fully differential channels) and four current channels operating from 0 mA to 20 mA. All channels have on-board overvoltage and overcurrent protection.

The EVAL-AD4112SDZ board includes voltage references and power and data insulation, and can be connected to the Analog Devices, Inc., **SDP-B** system demonstration platform (**EVAL-SDP-CB1Z**). The **SDP-B** board provides connection to a PC via a universal serial bus (USB) port and can provide power for the EVAL-AD4112SDZ board from the PC USB port.

The **AD411X Eval+** evaluation software configures the **AD4112** device functionality and provides dc time domain analysis in the form of waveform graphs, histograms, and associated noise analysis for ADC performance evaluation.

Full specifications for the **AD4112** are available in the product data sheet, which must be consulted in conjunction with this user guide when working with the EVAL-AD4112SDZ.

EVALUATION BOARD PHOTOGRAPH

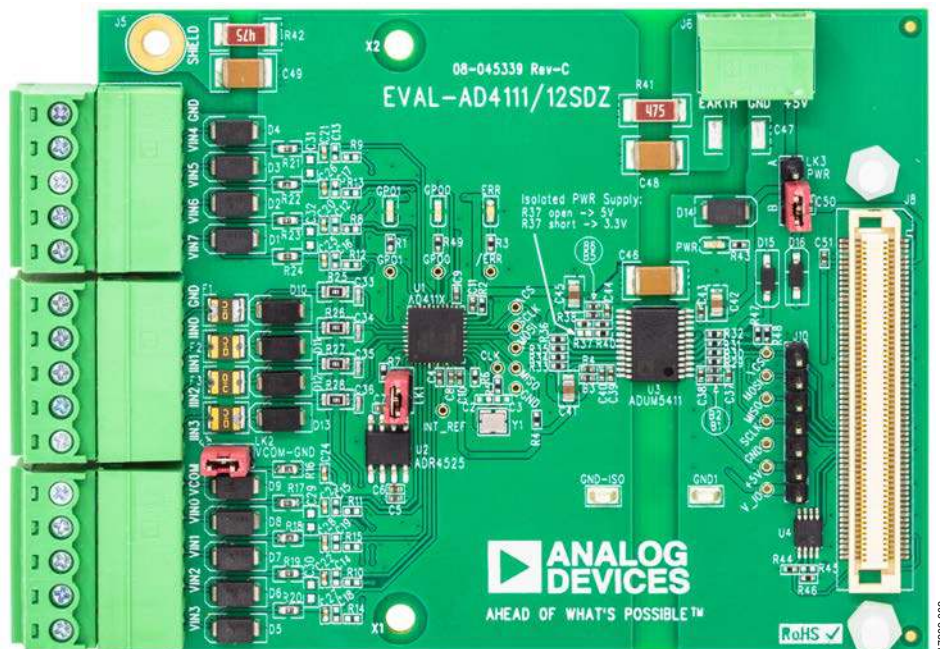

Figure 1.

TABLE OF CONTENTS

Features	1	Power Supplies.....	6
Evaluation Kit Contents.....	1	Analog Inputs	6
Equipment Needed.....	1	Reference Options.....	6
General Description.....	1	Evaluation Board Software.....	7
Evaluation Board Photograph.....	1	Software Installation Procedures.....	7
Revision History	2	Software Operation	10
Evaluation Board Block Diagram.....	3	Configuration Tab.....	10
EVAL-AD4112SDZ Quick Start Guide	4	Waveform Tabs	12
Recommended Quick Start Guide	4	Histogram Tab	14
Quick Start Measurement	4	Register Map Tab (Advanced Mode Only)	15
Evaluation Board Hardware.....	5	Exiting the Software.....	15
Device Description.....	5	Evaluation Board Schematics and Artwork.....	16
Hardware Link Options.....	5	Ordering Information.....	25
Evaluation Board Setup Procedure	5	Bill of Materials.....	25
Serial Interface	6		

REVISION HISTORY

1/2019—Rev. 0 to Rev. A

Changes to Figure 21	16
Changes to Figure 22.....	17
Changes to Figure 25.....	20
Changes to Figure 26.....	21
Changes to Figure 27.....	22
Changes to Figure 28.....	23
Changes to Figure 29.....	24
Changes to Table 3.....	25

8/2018—Revision 0: Initial Version

EVALUATION BOARD BLOCK DIAGRAM

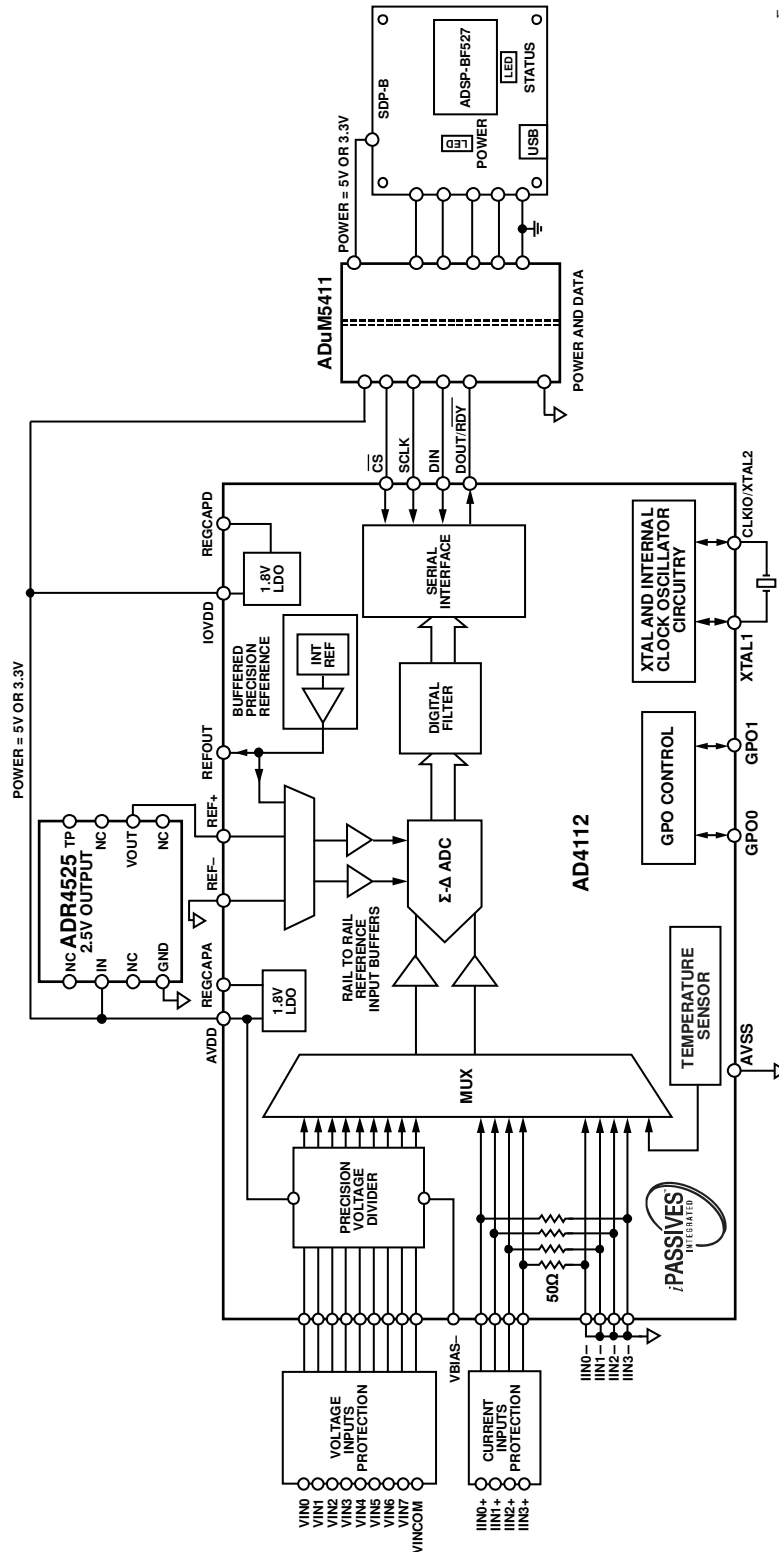

17209-001

Figure 2. Evaluation Board Block Diagram

NOTES
1. FOR SIMPLICITY DECOUPLING IS NOT SHOWN.

EVAL-AD4112SDZ QUICK START GUIDE

RECOMMENDED QUICK START GUIDE

Use the following procedure to set up the evaluation board:

1. Disconnect the **SDP-B** board from the USB port of the PC. Install the **AD411X Eval+** software. Restart the PC after installation.
2. Connect the **SDP-B** board to the EVAL-AD4112SDZ board, as shown in Figure 3.
3. Fasten the two boards together with the enclosed plastic screw washer set.
4. Connect the **SDP-B** board to the PC via the USB cable. For Windows® XP, it may be necessary to search for the system demonstration platform (SDP) drivers. Choose to automatically search for the drivers for the **SDP-B** board if prompted by the operating system.
5. Launch the **AD411X Eval+** software from the **Analog Devices** subfolder in the **Programs** menu.

QUICK START MEASUREMENT

Use the following procedure to capture data quickly:

1. Connect the dc signal source to selected voltage input (for example, VIN0 and VIN1 for differential input).
2. Launch the **AD411X Eval+** software and select **Quickstart**.
3. In the **Configuration** tab, under **Demo Mode**, click **All Single-Ended**, and then click **Sample** (see Figure 16).
4. In the **Voltage Waveform** tab, the user can evaluate the measured data.

The **Samples** box in the top right corner of the main window sets the number of samples collected in each batch.

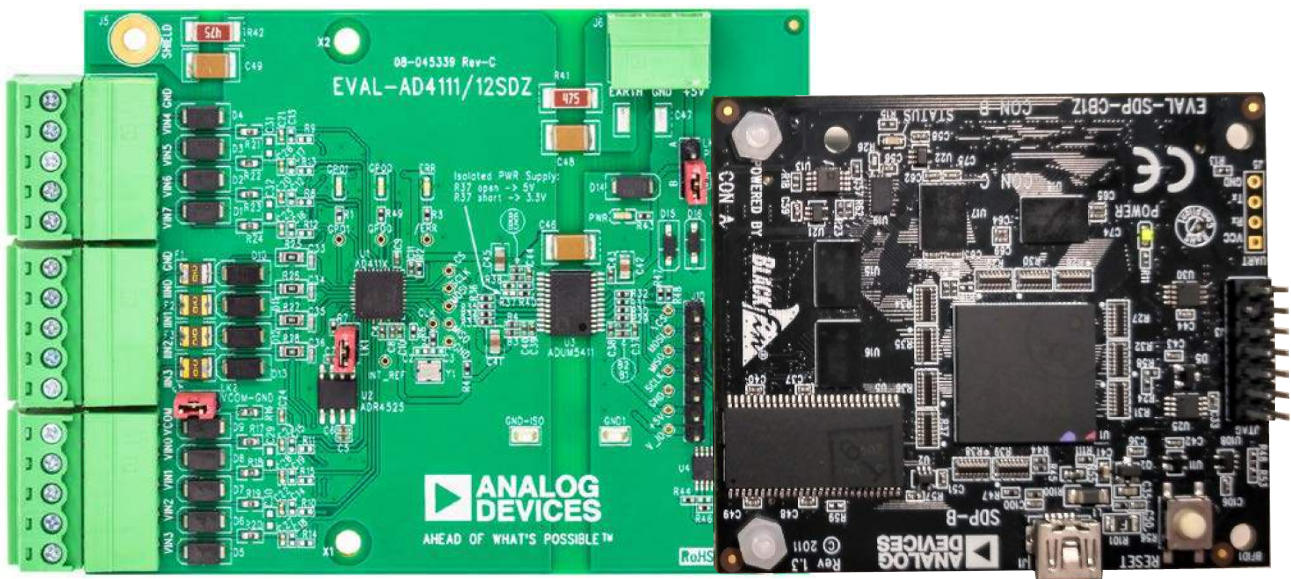

Figure 3. Hardware Configuration

EVALUATION BOARD HARDWARE

DEVICE DESCRIPTION

The [AD4112](#) is a highly accurate, high resolution, multiplexed, Σ - Δ ADC with four single-ended or eight differential voltage inputs, a voltage range of ± 10 V, and four current channels operating from -0.5 mA to $+24$ mA. The maximum channel to channel scan rate is 6.2 kSPS (161 μ s) for fully settled data. The output data rates range from 1.25 SPS to 31.25 kSPS. The device includes integrated analog reference buffers, an integrated precision 2.5 V reference, and an integrated oscillator.

See the [AD4112](#) data sheet for complete specifications. Consult the data sheet in conjunction with this user guide when using the evaluation board.

HARDWARE LINK OPTIONS

See Table 1 for the default link options. By default, the board is powered from the board connected to J8 ([EVAL-SDP-CB1Z](#)). The isolated voltage regulator (U3) output is set to 5 V.

EVALUATION BOARD SETUP PROCEDURE

After following the instructions in the Software Installation Procedures section, set up the evaluation board and SDP-B board as detailed in the Configuring the Evaluation and SDP-B Boards section.

The evaluation software and drivers must be installed before connecting the EVAL-AD4112SDZ evaluation board and [SDP-B](#) board to the USB port of the PC to ensure that the PC correctly recognizes the evaluation system.

Configuring the Evaluation and SDP-B Boards

Use the following procedure to configure the boards:

1. Connect the [SDP-B](#) board to Connector A or Connector B on the EVAL-AD4112SDZ board. Screw the two boards together firmly using the plastic screw and washer set included in the evaluation board kit.
2. Ensure that LK3 is in Position B (SDP).
3. Connect the [SDP-B](#) board to the PC using the USB cable.

Table 1. Default Link and Solder Link Options

Link	Default Option	Description
LK1	Inserted	Connects the on-board external reference ADR4525ARZ (U2) to AD4112 (U1). Remove LK1 if using a different single-ended external reference.
LK2	Inserted	Connects VCOM to GND_ISO. This configuration is typical for single-ended measurement. Remove LK2 to set the custom common analog input for single-ended channels. V_COM is available on Pin 5 of J1 or J4.
LK3	B (SDP)	Selects the power supply voltage. Position A: board is powered from the external dc power supply connector, J6 or J7. Position B: board is powered from the SDP connector, J8.
R37	Open	Sets the ADuM5411 (U3) isolated regulator output voltage. Open: +VA_ISO = 5 V. Short: +VA_ISO = 3.3 V.

SERIAL INTERFACE

The EVAL-AD4112SDZ board connects via the serial peripheral interface (SPI) to the Blackfin® [ADSP-BF527](#) on the [SDP-B](#) board. There are four primary signals, three inputs (\overline{CS} , SCLK, and DIN) and one output from the ADC (DOUT/ \overline{RDY}).

The EVAL-AD4112SDZ evaluation board connects to the [EVAL-ADuCM3029EZ-KIT](#) the same way. Connecting the evaluation board to the [EVAL-ADuCM3029EZ-KIT](#) allows the user to develop their own C code rather than using the provided evaluation software.

To operate the EVAL-AD4112SDZ in standalone mode, disconnect any board connected to J8 and use J10 to access all SPI signals and set the input/output voltage levels.

POWER SUPPLIES

By default, the board is powered from the [SDP-B](#) connector. The board can be also powered from the J6 and J7 connectors by setting LK3 to Position A or from Pin +5V on Connector J10 (see Table 2).

The [ADuM5411](#) *isoPower*® digital isolator is used to isolate power and data lines up to 2.5 kV rms.

ANALOG INPUTS

There are two types of analog inputs: voltage and current.

Eight voltage inputs are available on J1 and J2. Four current inputs are available on J3.

If a different common voltage must be set for single-ended measurement, remove LK2 and connect the desired voltage to V_COM on J1.

REFERENCE OPTIONS

The EVAL-AD4112SDZ includes an external 2.5 V reference, the [ADR4525ARZ](#). By default, LK1 is inserted, connecting the external reference to REF+ of the [AD4112](#).

Remove LK1 if using a different single-ended external reference.

In the evaluation software, click the blue pop-up button associated with Setup 0 to Setup 7 to select the reference used for conversions by the [AD4112](#). The pop-up button is located below the external reference controls in the block diagram (Label 9 in Figure 16).

Table 2. Connector Details

Connector	Function	Connector Type	Manufacturer	Part Number
J1, J2, J4	Voltage inputs to ADC	Connector, header, 90°, 5-position, 3.81 mm	Phoenix Contact	MC 1.5/5-G-3.81
J3, J4	Current inputs to ADC	Connector, header, 90°, 5-position, 3.81 mm	Phoenix Contact	MC 1.5/5-G-3.81
J5	Earth for electrostatic discharge (ESD) testing	1.25-MS3 ring tongue terminal, M3, Number 5, 16 AWG, 1.65 mm ²	Japan Solderless Terminals	1.25-MS3
J6, J7	External supply voltage (optional)	Connector, header, 90°, 5-position, 3.81 mm	Phoenix Contact	MC1.5/3-G-3.81
J8	Connector to the EVAL-ADuCM3029EZ-KIT or EVAL-SDP-CB1Z	120-way connector, 0.6 mm pitch	Hirose	FX8-120S-SV(21)
J10	SPI and power terminal	Header, in line, 7-position, 100 mil	Würth Elektronik	61300711121

EVALUATION BOARD SOFTWARE SOFTWARE INSTALLATION PROCEDURES

The EVAL-AD4112SDZ evaluation kit includes a link to the software that needs to be installed before using the EVAL-AD4112SDZ evaluation board.

There are two parts to the installation:

- AD411X Eval+ software installation
- EVAL+ Dependencies installation, including SDP-B board drivers

The evaluation software and drivers must be installed before connecting the EVAL-AD4112SDZ evaluation board and SDP-B board to the USB port of the PC to ensure that the PC correctly recognizes the evaluation system.

Installing the AD411X Eval+ Software

To install the AD411X Eval+ software,

1. With the SDP-B board disconnected from the USB port of the PC, download and unzip the AD411X Eval+ software installer file from the EVAL-AD4112SDZ product page.
2. Double-click the **setup.exe** file to begin the evaluation board software installation. The software then installs to the following default location: **C:\Program Files\Analog Devices\AD411X EVAL+**.
3. A dialog box appears asking for permission to allow the program to make changes to the PC. Click **Yes**.



Figure 4. Granting Permission for the Program to Make Changes to PC

4. Select a location to install the software and then click **Next**. Figure 5 shows the default locations, which are displayed when the dialogue box opens, but another location can be selected by clicking **Browse**.

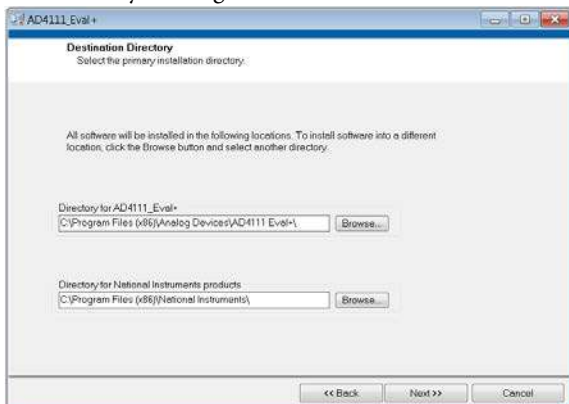

Figure 5. Selecting the Location for Software Installation

5. A license agreement appears. Read the agreement, select **I accept the License Agreement**, and click **Next**.

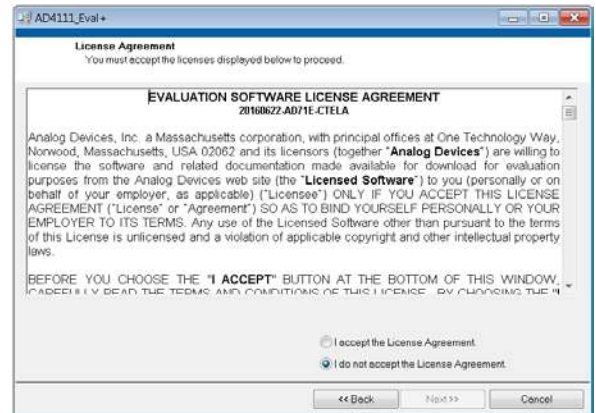

Figure 6. Accepting the License Agreement

6. A summary of the installation displays. Click **Next** to continue.

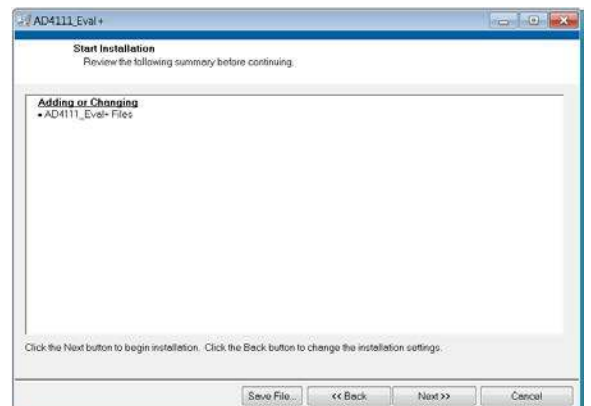

Figure 7. Reviewing a Summary of the Installation

7. The message in Figure 8 appears when the installation is complete. Click **Next**.

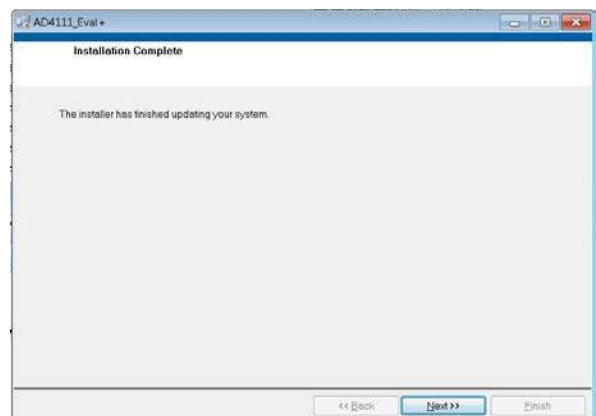

Figure 8. Indicating when the Installation is Complete

Installing the Eval+ Dependencies Drivers

After the installation of the evaluation software is complete, a welcome window appears for the installation of the **Eval+ Dependencies**.

1. With the **SDP-B** board still disconnected from the USB port of the PC, ensure that all other applications are closed, and then click **Install**.

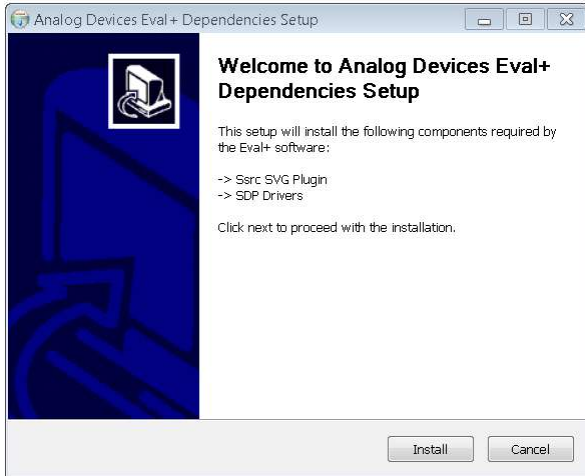

Figure 9. Beginning the Drivers Installation

2. To complete the driver installation, click **Close**, which closes the installation setup wizard.

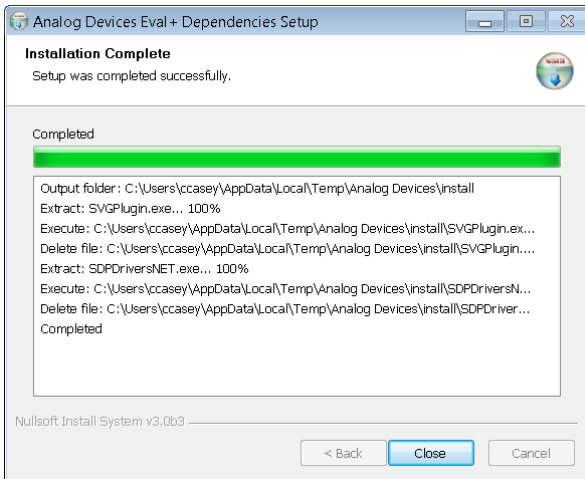

Figure 10. Completing the Drivers Setup Wizard

3. Before using the evaluation board, restart the PC.

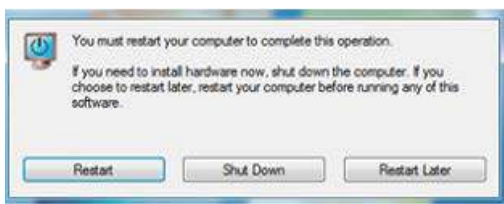

Figure 11. Restarting the PC

Setting Up the System for Data Capture

After completing the steps in the Software Installation Procedures section and the Evaluation Board Hardware section, set up the system for data capture as follows:

1. Allow the **Found New Hardware** wizard to run after connecting the **SDP-B** board to the PC. If using Windows XP, it may be necessary to search for the **SDP-B** drivers. Choose to automatically search for the drivers for the **SDP-B** board if prompted by the operating system.
2. Check that the board is connecting to the PC correctly using the **Device Manager** of the PC. Access the **Device Manager** as follows:
 - a. Right-click **My Computer** and then click **Manage**.
 - b. A dialog box appears asking for permission to allow the program to make changes to the PC. Click **Yes**.
 - c. The **Computer Management** window appears. Click **Device Manager** from the **System Tools** list (see Figure 12).
 - d. If the **SDP-B** board appears under **ADI Development Tools** in the **TEST PC** nested list, the driver software has installed and the board is connecting to the PC correctly.

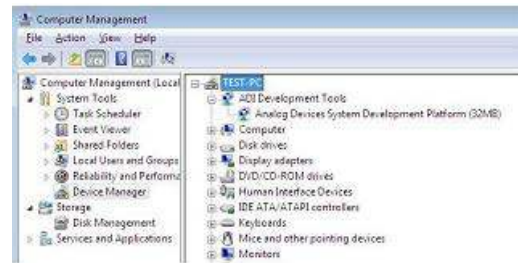

Figure 12. Checking if the Board is Connected to the PC Correctly

Launching the Software

After completing the steps in the Setting Up the System for Data Capture section, launch the **AD411X Eval+** software as follows:

1. From the **Start** menu, click **Programs > Analog Devices > AD411X Eval+ > AD411X Eval+**. The dialog box shown in Figure 13 appears. Select **AD4112 Evaluation Board** and the main window of the software shown in Figure 16 appears.

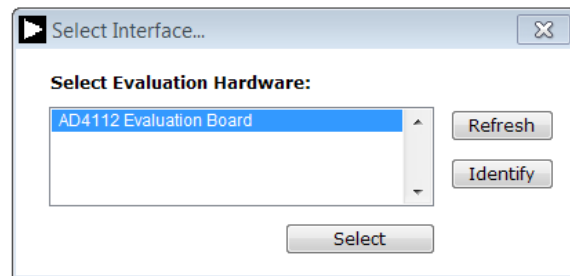

Figure 13. AD4112 Evaluation Board Selection

- If the EVAL-AD4112SDZ evaluation system is not connected to the USB port via the SDP-B when the software is launched, the software displays the dialog box shown in Figure 14. Connect the evaluation board to the USB port of the PC, wait a few seconds, then click **Refresh**, and the dialog box shown in Figure 13 appears.

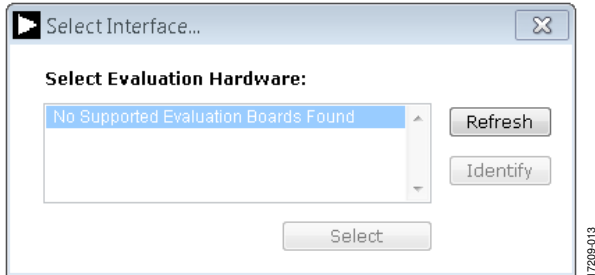

Figure 14. Evaluation Board Selection, No Board Connected

- The dialog box shown in Figure 15 appears. Quickstart mode provides a simplified version of the software that can be used as a starting point for evaluating the AD4112. This mode provides a graphical user interface (GUI) for setting up inputs, as shown in Figure 16, and allows the user to configure the device further by using the blue configuration buttons (Label 7 Figure 16).
- Advanced mode can be used when more configurability of the inputs is required. In this mode, the input GUI is not available. However, the user has access to the **Registers** tab, which provides full control of the AD4112 register map. When operating in advanced mode, the user must consult the AD4112 data sheet.

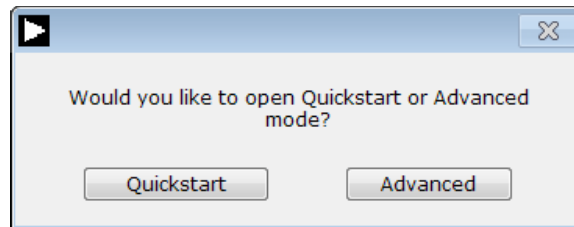

Figure 15. AD411X Eval+ Startup Mode Selection

Inputs		
Voltage	Current	
SE Diff	Range	
Vin 0 <input type="checkbox"/>	<input checked="" type="checkbox"/> +/-10V	Iin 0 <input type="checkbox"/>
Vin 1 <input type="checkbox"/>	<input type="checkbox"/> +/-10V	Iin 1 <input type="checkbox"/>
Vin 2 <input type="checkbox"/>	<input type="checkbox"/> +/-10V	Iin 2 <input type="checkbox"/>
Vin 3 <input type="checkbox"/>	<input type="checkbox"/> +/-10V	Iin 3 <input type="checkbox"/>
Vin 4 <input type="checkbox"/>	<input type="checkbox"/> +/-10V	
Vin 5 <input type="checkbox"/>	<input type="checkbox"/> +/-10V	
Vin 6 <input type="checkbox"/>	<input type="checkbox"/> +/-10V	
Vin 7 <input type="checkbox"/>	<input type="checkbox"/> +/-10V	

ODR(Hz)	Time(ms)	Total Time
31250	0.0032	0.0032

Figure 16. Configuration Tab in Quickstart Mode

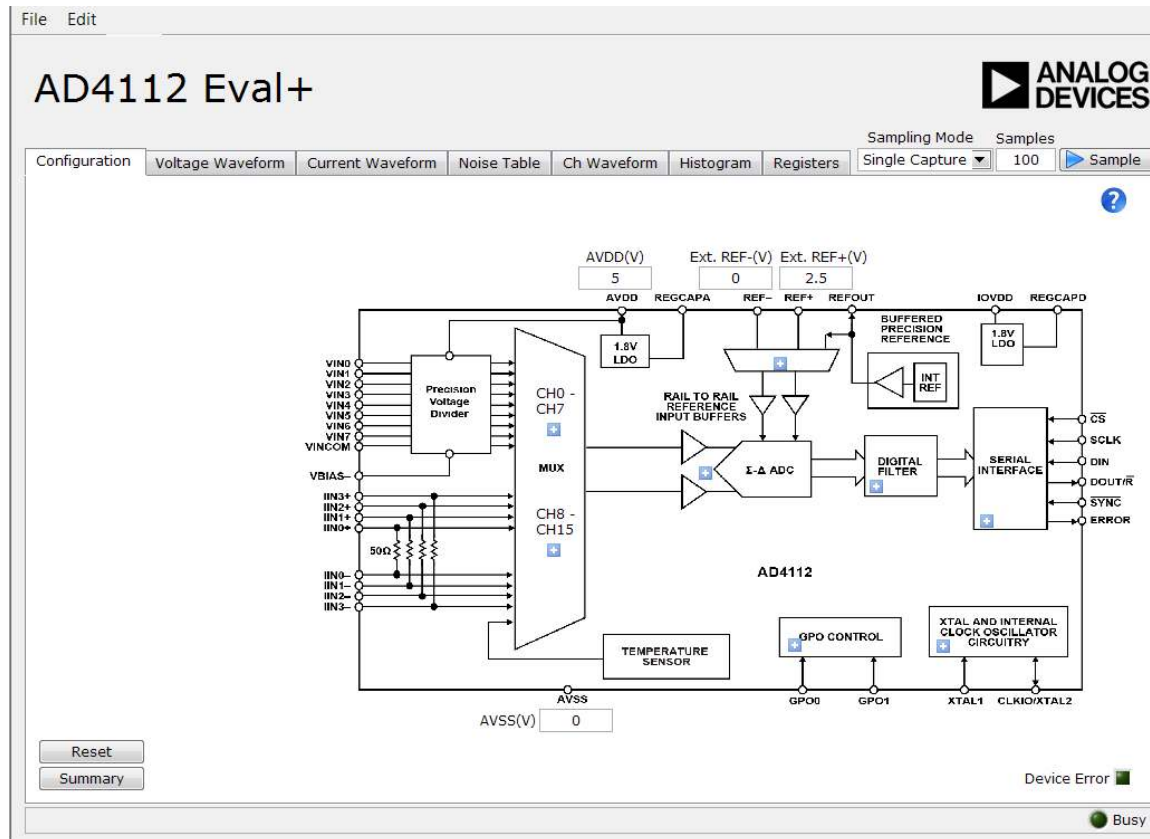

Figure 17. Configuration Tab in Advanced Mode

SOFTWARE OPERATION

Overview of the Main Window

After selecting **AD4112 Evaluation Board**, the main window of the evaluation software displays, as shown in Figure 16. This tab shows the control buttons and analysis indicators of the **AD411X Eval+** software. The main window of the **AD411X Eval+** software in **Quickstart** mode contains five tabs: **Configuration**, **Voltage Waveform**, **Current Waveform**, **Noise Table**, and **Histogram**.

In advanced mode, two additional tabs are available: **Ch Waveform** and **Registers**.

CONFIGURATION TAB

The **Configuration** tab shows a block diagram of the **AD4112**. This tab allows the user to select inputs, set up the ADC, reset the ADC, view errors present, and configure the device for different demonstration modes. Figure 16 shows the **Configuration** tab in detail, and the following sections discuss the different elements on the **Configuration** tab of the software window.

Inputs (Quickstart Mode Only)

The **AD4112** has eight voltage inputs, which can be configured as single-ended or fully differential pairs, and four current inputs (Label 1 in Figure 16).

The voltage range can also be set per input to ± 10 V, ± 5 V, 0 V to 10 V, or 0 V to 5 V. Changing the appropriate voltage range

provides more realistic values for **P - P Resolution** and **RMS Resolution** shown in the **Noise Analysis** area (Label 22 in Figure 18).

Output Data Rate (ODR)/Measurement Time

The ODR can be set for all inputs in the **Configuration** tab (Label 2 in Figure 16). Set the ODR by entering a value in hertz into the **ODR(Hz)** box or a measurement time in milliseconds into the **Time(ms)** box. If an ODR is entered, the software calculates the measurement time. If a time is entered, the software calculates the fastest ODR that can achieve the required measurement time.

The device only supports a certain number of ODRs. Therefore, the software rounds up to the closest available value. ODR values depend on if a single or multiple channels are enabled. The fastest ODRs are available if only one channel is enabled. The values shown are valid for the sinc5 + sinc1 filter, which is enabled by default. If the sinc3 filter is enabled instead, refer to the **AD4112** data sheet for the corresponding values.

The value in the **Time(ms)** box represents time taken for one sample for one enabled channel.

The value in the **Total Time** box represents the total time to take one sample for all enabled **Inputs**.

Demo Modes

The AD411X Eval+ software contains a number of demonstration modes in the **Demo Modes** area (Label 3 in Figure 16). These demonstration modes configure the AD4112 for each of the input types (represented by the **All Single-Ended**, **All Differential**, and **All Current** buttons).

Reset

Click **Reset** to perform a software reset of the AD4112 (Label 4 in Figure 16). There is no hardware reset pin on the AD4112.

To perform a hard reset, remove power from the board. The software reset has the same effect as a hard reset.

Tutorial Button

Click the tutorial button (Label 5 in Figure 16) to open a tutorial on using the software and additional information on using the AD411X Eval+ software. Click the blue information buttons for further information on different elements of the **Configuration** tab.

Functional Block Diagram

The functional block diagram of the AD4112 (Label 6 in Figure 16) shows each of the functional blocks within the AD4112. Clicking a configuration button on the block diagram opens the configuration window for that block.

Configuration Pop-Up Button

Each configuration button (Label 7 in Figure 16) opens a different window to configure the relevant functional block.

External Parameters

There are three external parameters that are set by the EVAL-AD4112SDZ board but must be entered into the software: the external reference (Label 8 in Figure 16), AVDD (Label 9 in Figure 16), and AVSS (Label 10 in Figure 16). The external reference on the EVAL-AD4112SDZ board is set to 2.5 V by using an ADR4525. If bypassing the ADR4525 on board, change the external reference voltage value in the software to ensure correct calculation of results in the **Waveform** and **Histogram** tabs.

Configuration Summary

Clicking **Summary** (Label 11 in Figure 16) shows the input configuration, channel configuration, and information on each of the individual setups as well as information on any error present. These tabs can be used to quickly check how the ADC inputs and channels are configured, as well as any errors that are present.

Status Bar

The status bar (Label 12 in Figure 16) displays status updates such as **Analysis Completed**, **Reset Completed**, and **Writing to Registers** during software use, as well as the **Busy** indicator.

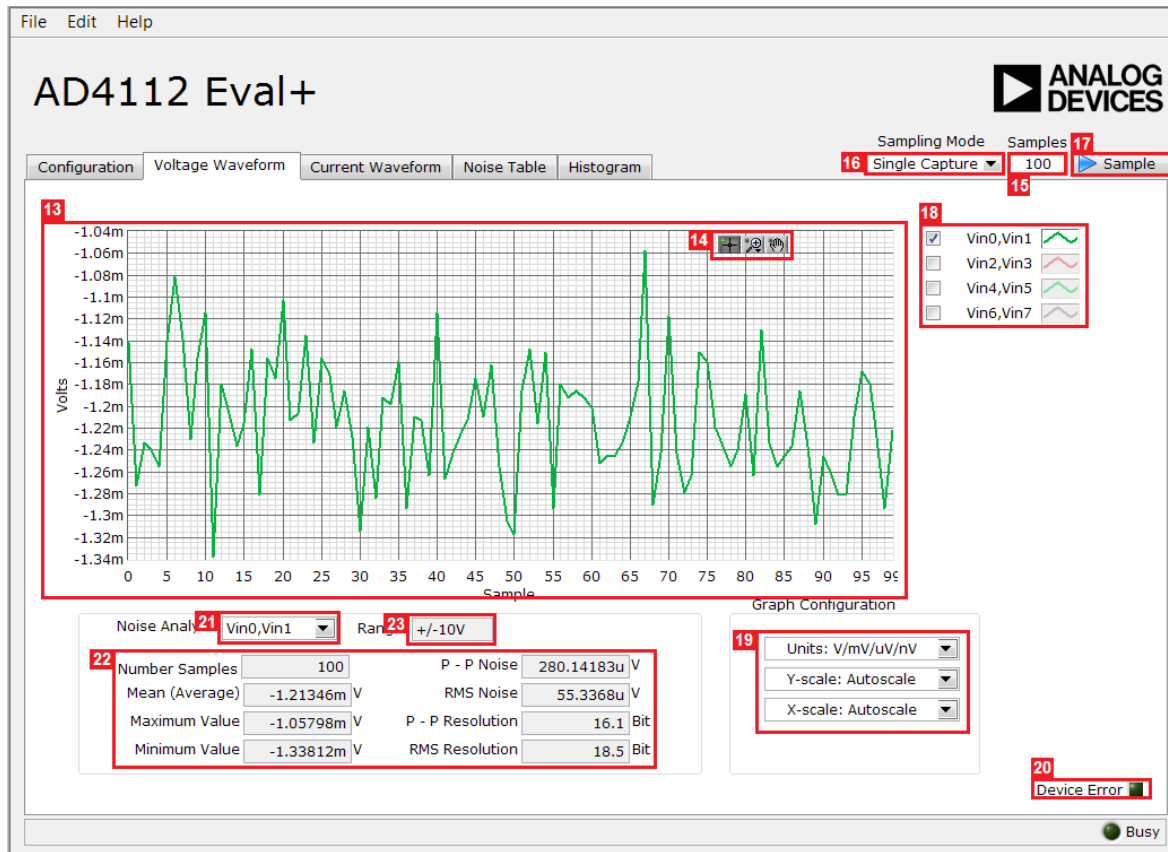

Figure 18. Voltage Waveform Tab

WAVEFORM TABS

The AD411X Eval+ software has three different waveform tabs: **Voltage Waveform**, **Current Waveform**, and **Ch Waveform** (in advanced mode only). The waveform tabs graph the conversions gathered and processes the data, calculating the peak-to-peak noise, rms noise, and resolution (see Figure 18). The **Voltage Waveform** tab graphs the data at the voltage input. The **Current Waveform** tab graphs the data at the current inputs, which are displayed in amps. The **Ch Waveform** tab displays both voltage and current inputs as voltages.

Waveform Graph and Controls

The data waveform graph (Label 13 in Figure 18) shows each successive sample of the ADC output. Zoom in on the data in the graph using the control buttons (Label 14 in Figure 18). Change the scales on the graph by typing values into the x-axis and y-axis.

Samples

The **Samples** box (Label 15 in Figure 18) and **Sampling Mode** (Label 16 in Figure 18) set the number of samples gathered per batch. If **Sampling Mode** is set to **Single Capture**, the ADC returns the number of samples specified in the **Samples** box. If **Sampling Mode** is set to **Continuous**, the ADC continuously returns samples until stopped by the user. **Samples** specifies the amount of samples to be shown on the data graph. **Samples** is unrelated to the ADC mode.

Sample

Click **Sample** (Label 17 in Figure 18) to start gathering ADC results. Results appear in the waveform graph.

Plot Selection

The plot selection control area (Label 18 in Figure 18) allows the user to select which inputs display on the data waveform and shows the name of the input.

These controls only affect the waveform graphs and have no effect on the channel settings in the ADC register map.

Display Units and Axis Controls

Click the **Units** box in the **Graph Configuration** area (Label 19 in Figure 18) to select whether the data graph displays in units of voltage in amps or codes. This control is independent for each graph. The **Y-scale** and **X-scale** boxes can be set to autoscale or fixed scaling. When **Autoscale** is selected, the axis automatically adjusts to show the entire range of the ADC results after each batch of samples. When **Fixed** is selected, the axis range can be set by the user. These ranges do not automatically adjust after each batch of samples.

Device Error

The **Device Error** indicator (Label 20 in Figure 18) illuminates in the **Waveform** tab when a cyclic redundancy check (CRC) error or an error in the ADC is detected. More specific information on the error can be by clicking **Summary** in the **Configuration** tab (Label 11 in Figure 16).

Analysis Input

The **Noise Analysis** box shows the analysis of the input selected via the analysis control (Label 21 in Figure 18).

Noise Analysis

The **Noise Analysis** area (Label 22 in Figure 18) displays the results of the noise analysis for the selected analysis input, including both noise and resolution measurements.

Input Range

The **Range** box (Label 23 in Figure 18) is an indicator in quickstart mode. The value is selected in the inputs area on the **Configuration** tab (Label 1 in Figure 16). In advanced mode, **Range** is a control that allows the user to select an input range for the input chosen for noise analysis.

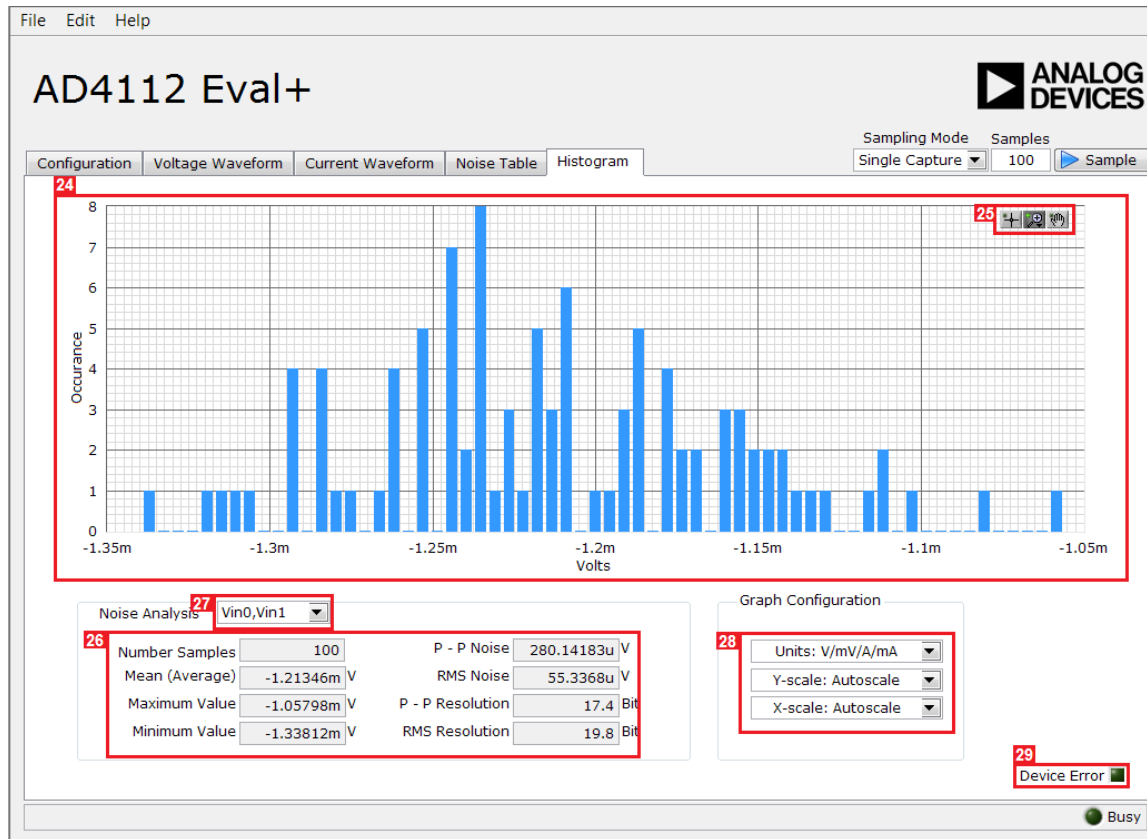

Figure 19. **Histogram** Tab of the **AD411X Eval+** Software

HISTOGRAM TAB

The **Histogram** tab generates a histogram using the gathered samples and processes the data to calculate the peak-to-peak noise, rms noise, and resolution (see Figure 19). There is only one histogram tab for the current and voltage inputs.

Histogram Graph and Controls

The data histogram graph (Label 24 in Figure 19) shows the number of times each sample of the ADC output occurs. Zoom in on the data using the control buttons (Label 25 in Figure 19) in the graph. Change the scales on the graph by typing values into the x-axis and y-axis.

Analysis Input

The data used to generate the histogram and values in the **Noise Analysis** area (Label 26 in Figure 19) is set by the **Noise Analysis** box (Label 27 in Figure 19). All enabled inputs appear here in the **Noise Analysis** box.

Noise Analysis

The **Noise Analysis** area (Label 26 in Figure 19) displays the results of the noise analysis for the selected analysis input, including both noise and resolution measurements.

Display Units and Axis Controls

Click the **Units** box in the **Graph Configuration** area (Label 28 in Figure 19) to select whether the data graph displays in units of voltages/amps or codes. This control is independent for each graph.

The **Y-scale** and **X-scale** boxes can be set to autoscale or fixed scaling. When **Autoscale** is selected, the axis automatically adjusts to show the entire range of the ADC results after each batch of samples. When **Fixed** is selected, the user can set the axis range. These ranges do not automatically adjust after each batch of samples.

Device Error

The **Device Error** indicator (Label 29 in Figure 19) illuminates in the **Histogram** tab when a CRC error or an error in the ADC is detected. More specific information on the error can be by clicking **Summary** in the **Configuration** tab (Label 11 in Figure 16).

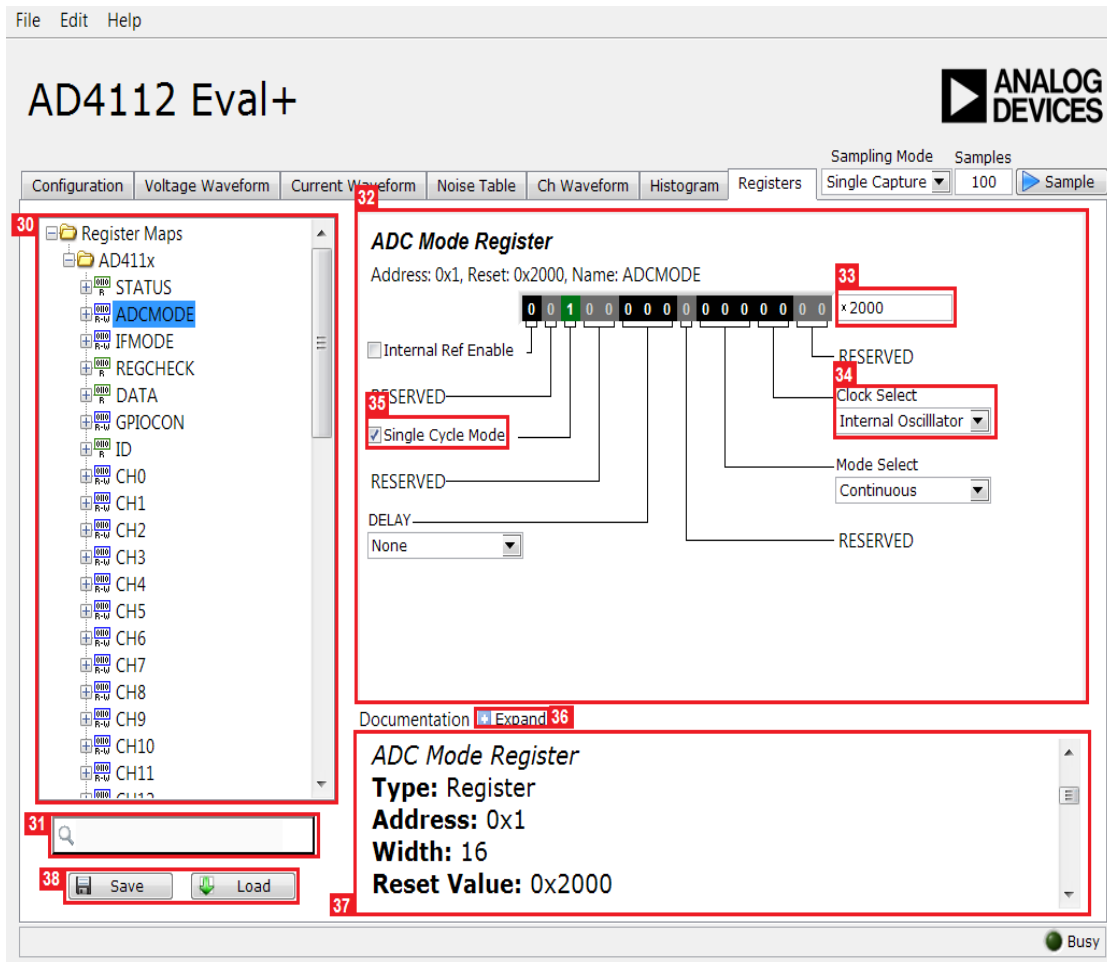

Figure 20. Register Tab

REGISTER MAP TAB (ADVANCED MODE ONLY)

Register Maps List

Clicking the register maps nested list (Label 30 in Figure 20) shows each register. Clicking the expand button next to each register shows all the bit fields contained within that register.

Register Maps Search

The search box (Label 31 in Figure 20) allows the user to search the register maps list for any register or bit field. Entering a value into this control filters the register list.

Register and Bit Field Control

The register control area (Label 32 in Figure 20) allows the user to change the individual bit of the register selected in the register by clicking the bits or by programming the register value directly into the value control box (Label 33 in Figure 20). The register and bit controls also show all bit fields for the selected register. Change the values by using the dropdown

boxes (Label 34 in Figure 20) or by selecting or clearing a check box (Label 35 in Figure 20).

Documentation

The **Documentation** area (Label 37 in Figure 20) contains the documentation for the register or the bit field selected. This field can be updated by selecting a register or bit field in the register list or hovering over the register or bit field in the register list or register control. The documentation area can also be displayed in a separate window by clicking **Expand** (Label 36 in Figure 20).

Save and Load

Save and Load (Label 38 in Figure 20) allow the user to save the current register map setting to a file and to load the setting from the same file, respectively.

EXITING THE SOFTWARE

To exit the software, click the close button in the title bar.

EVALUATION BOARD SCHEMATICS AND ARTWORK

17209-017

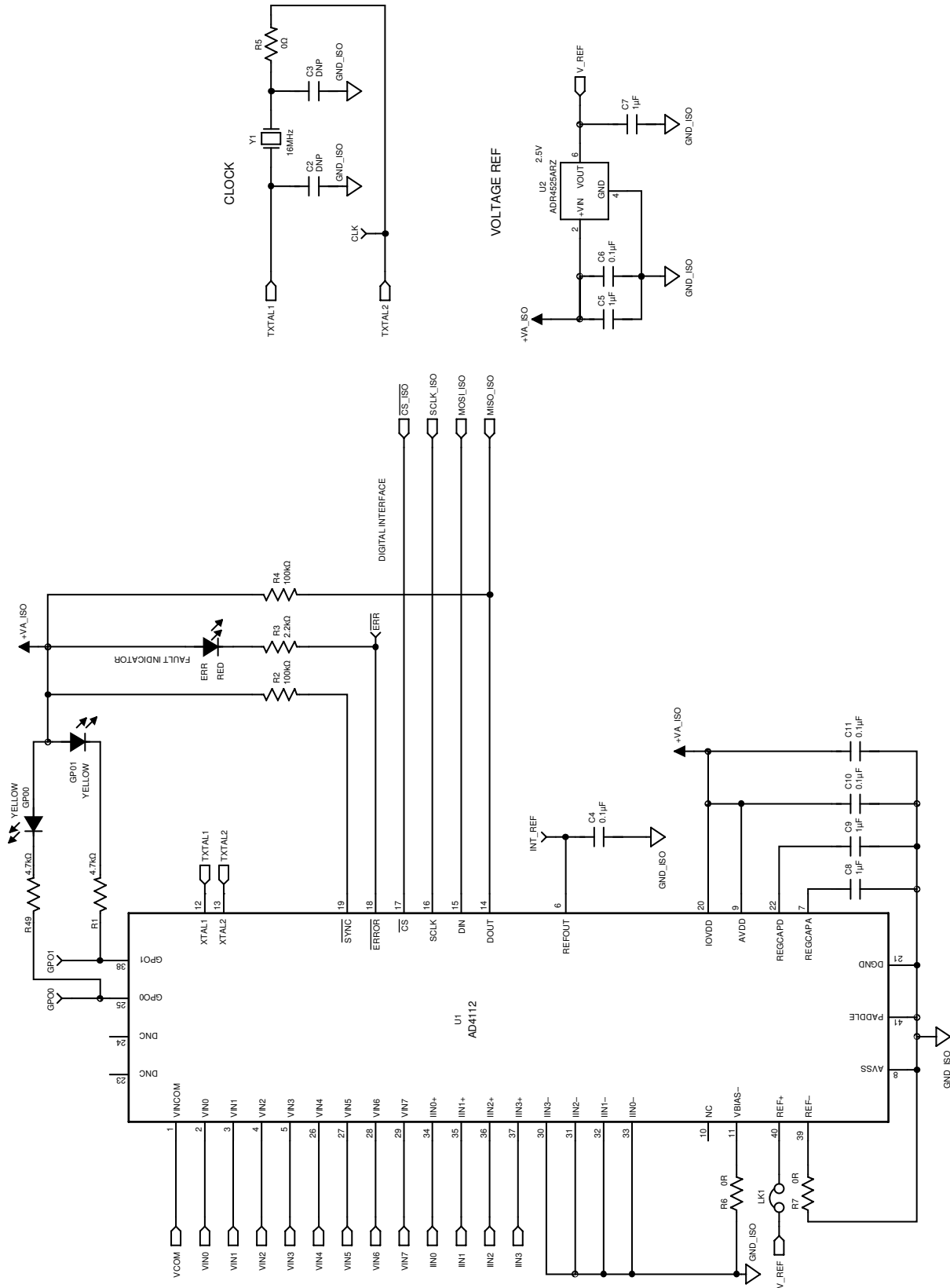

Figure 21. AD4112 Schematic

17209-018

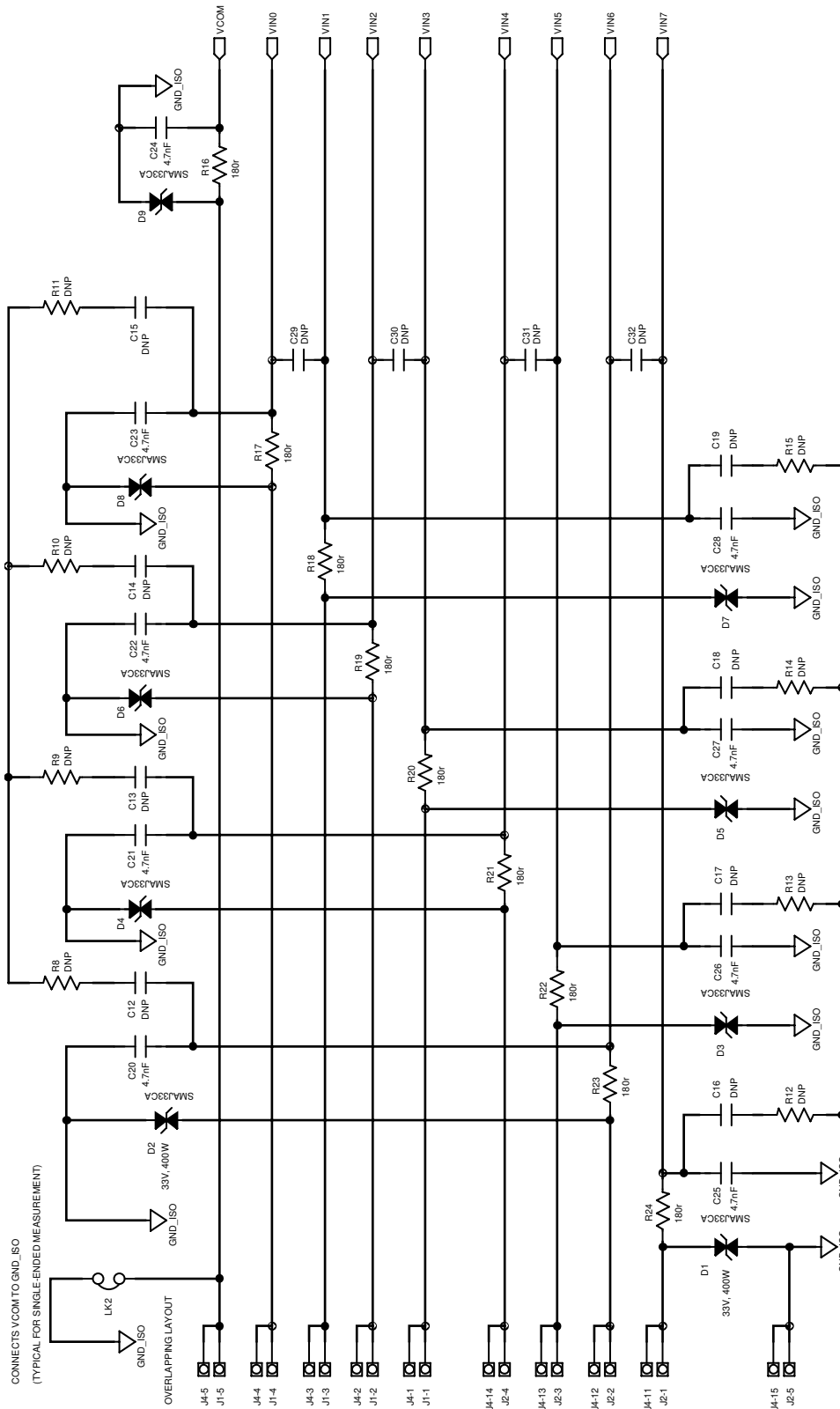

Figure 22. Voltage Input Front End Schematic

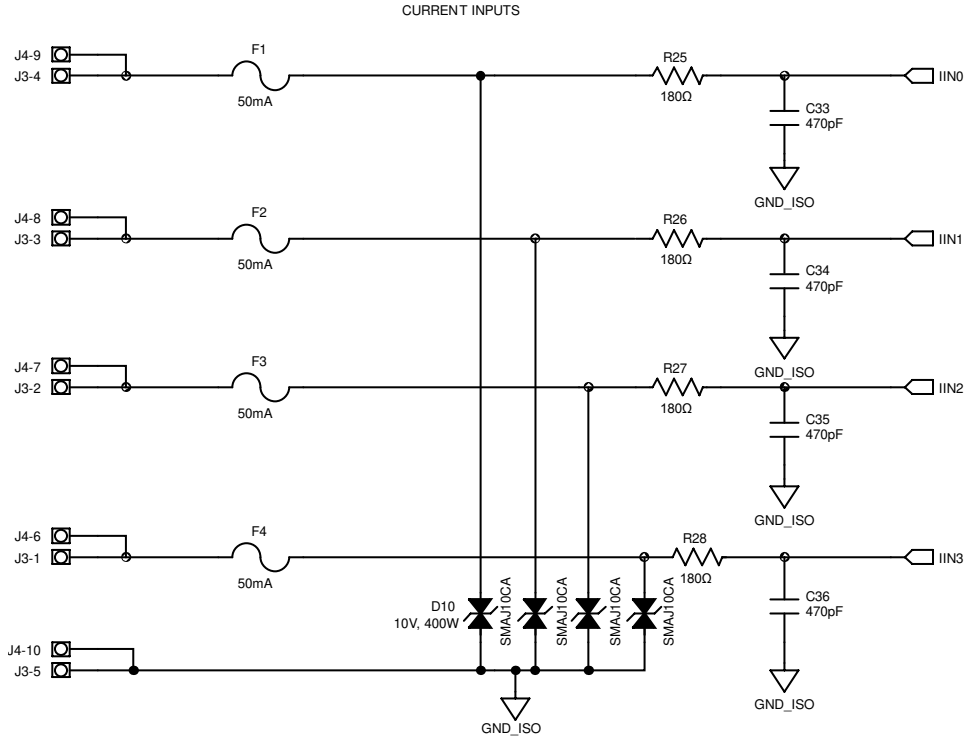

Figure 23. Current Input Front End Schematic

17209-019

17209-020

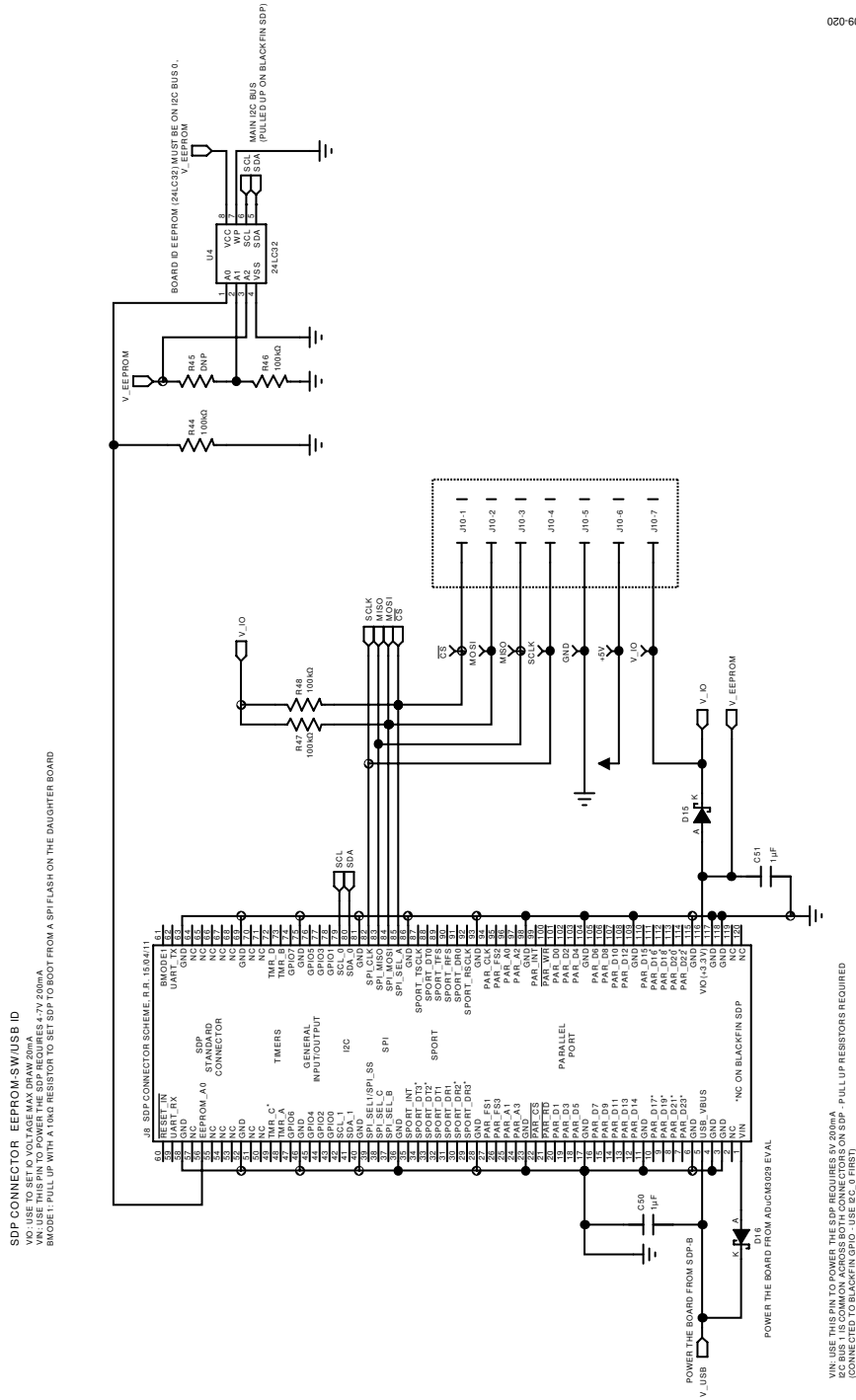

Figure 24. SDP Connector Schematic

17209-121

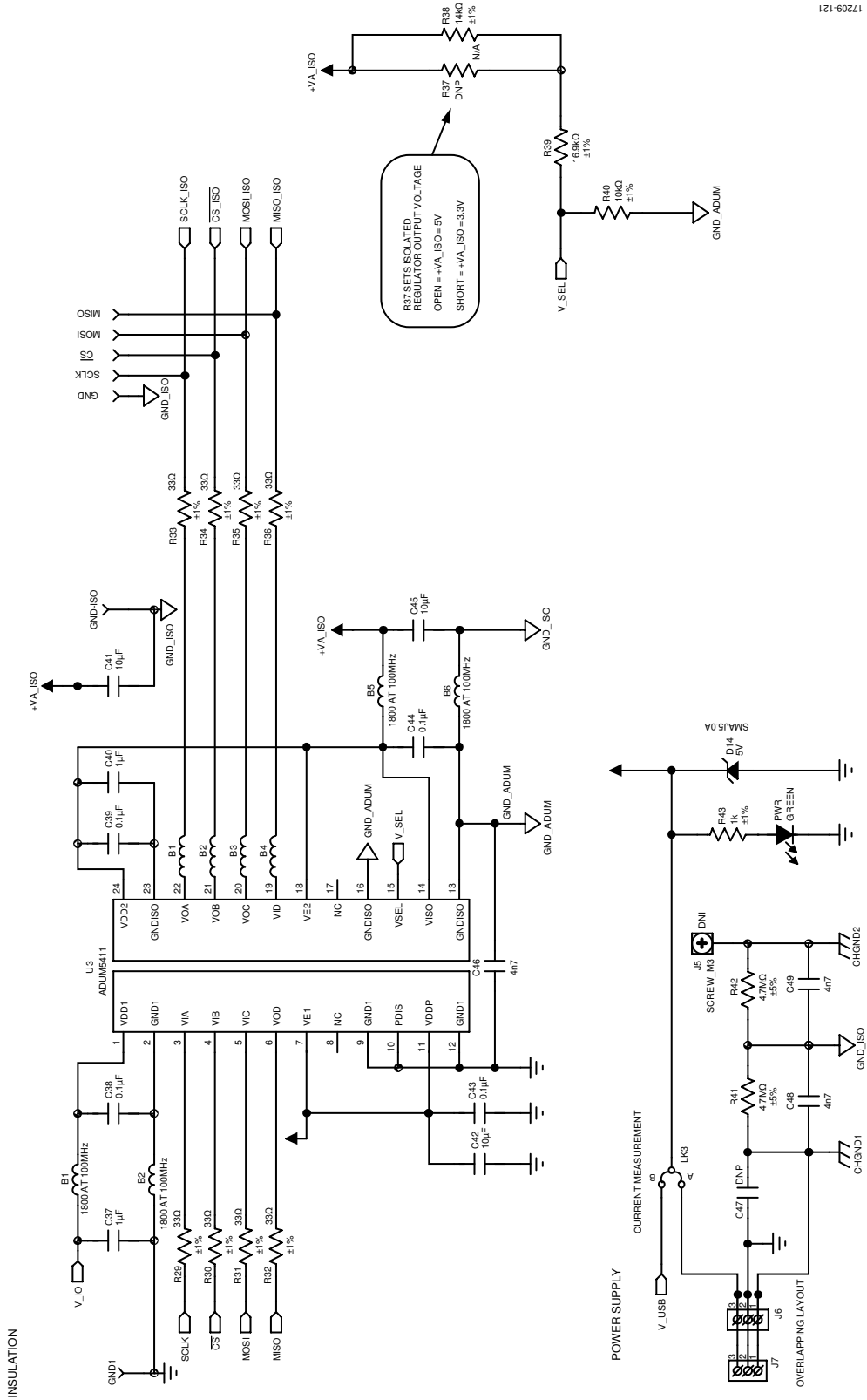

Figure 25. Insulation and Power Supply Schematic

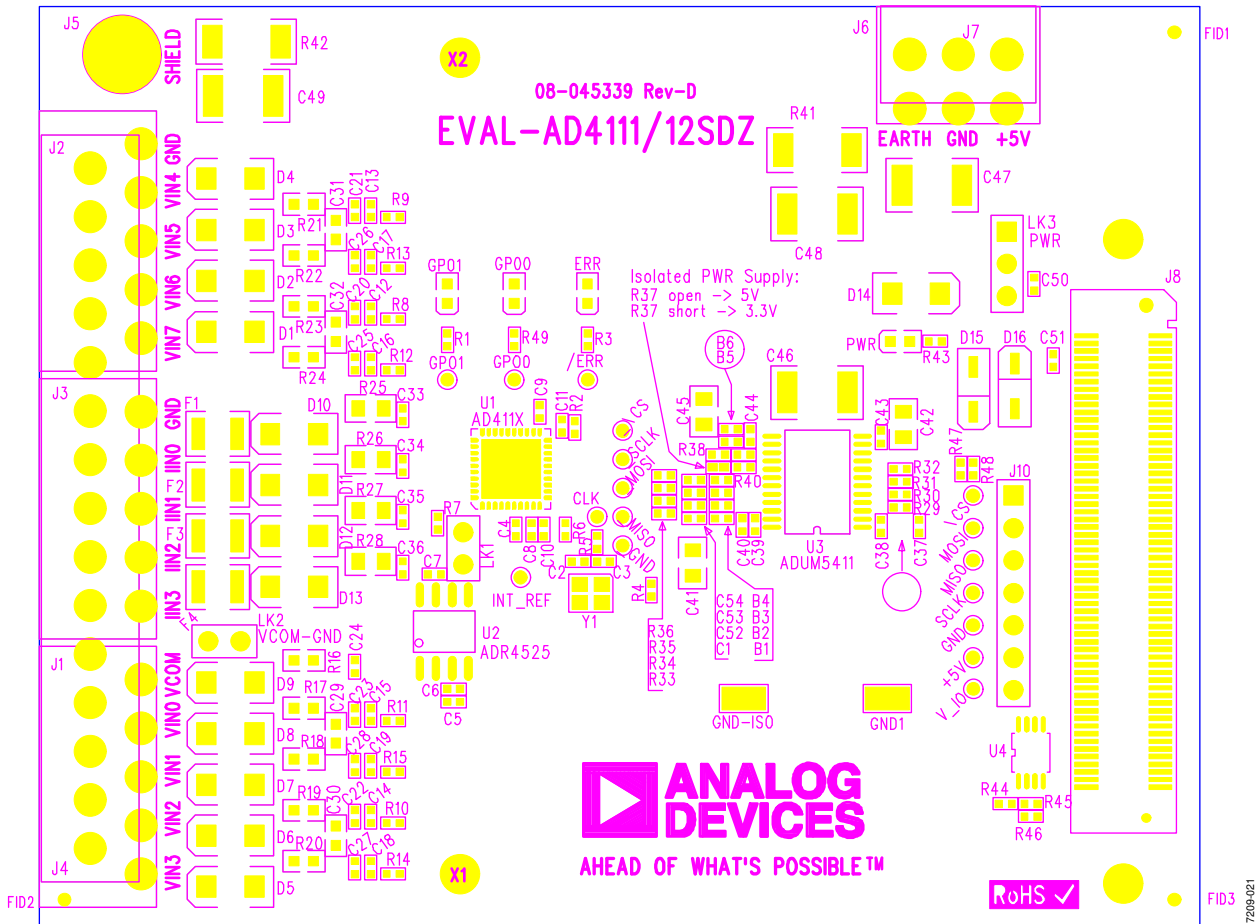

Figure 26. Top Printed Circuit Board (PCB)

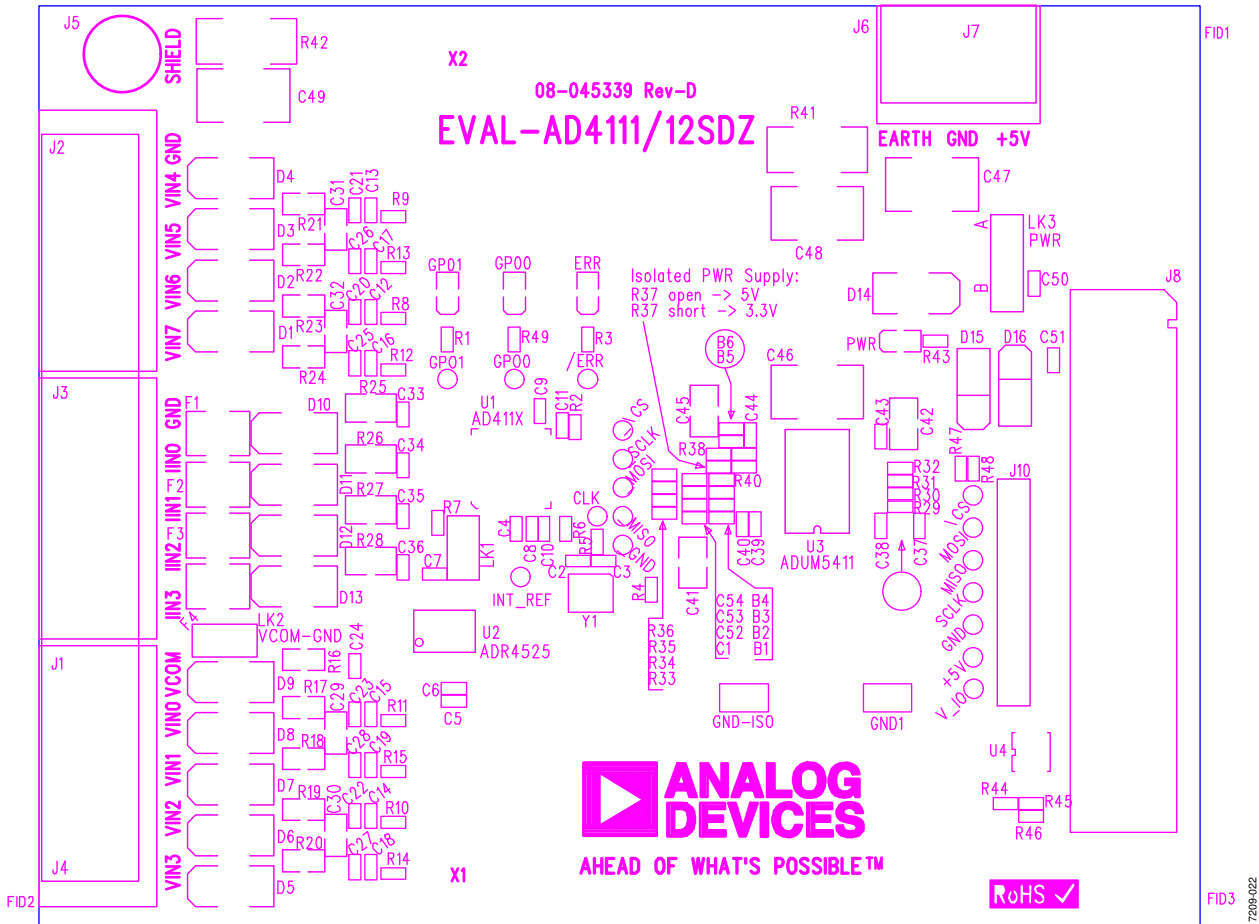
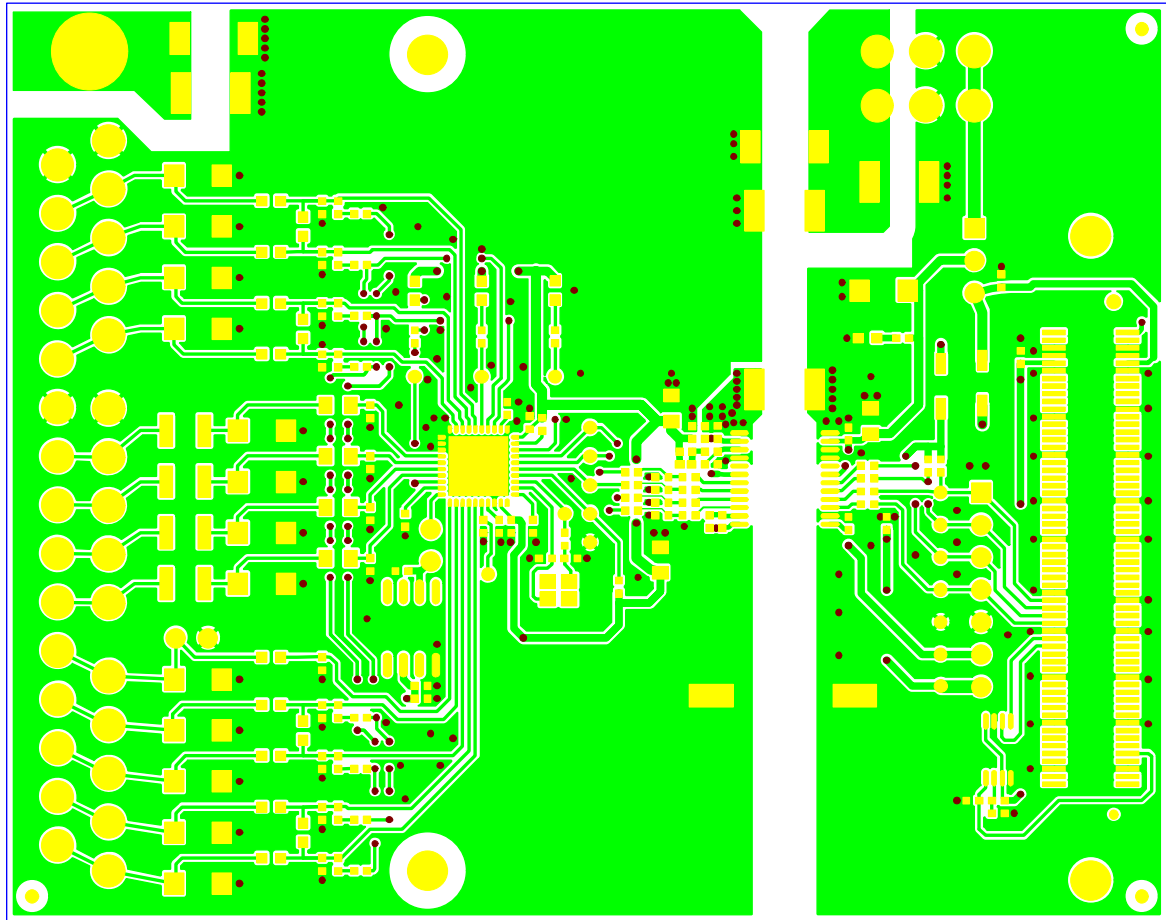

Figure 27. Component Side Silkscreen Top

17209-022



17209-023

Figure 28. Layer 1 Component Side

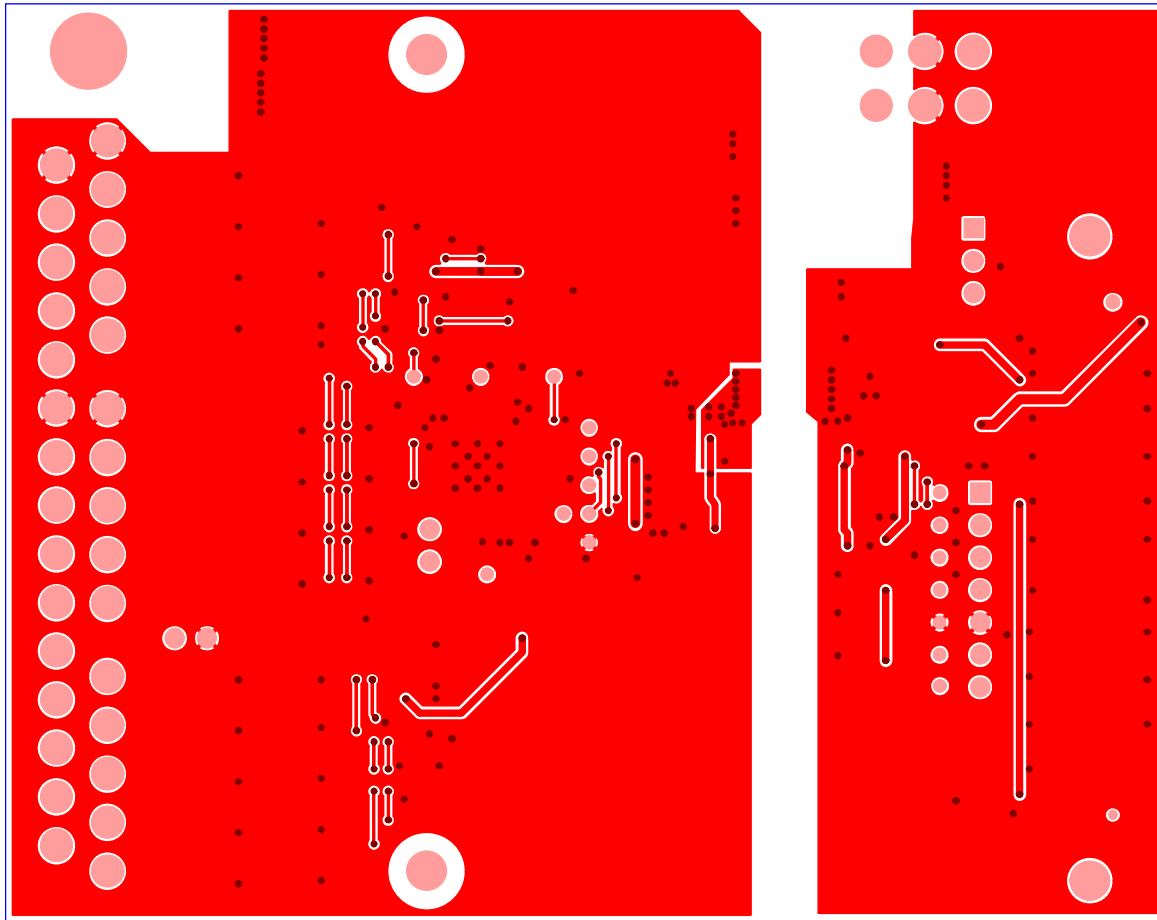

17209-024

Figure 29. Layer 2 Solder Side

ORDERING INFORMATION

BILL OF MATERIALS

Table 3. Bill of Materials

Reference Designator	Value	Description	Manufacturer	Part Number
B1 to B6	1800 Ω	B0402, 1800 Ω at 100 MHz, 200 mA	Murata	BLM15HD182SN1D
C2	Do not place (DNP)	C0402, DNP	Not applicable	Not applicable
C3	DNP	C0402, DNP	Not applicable	Not applicable
C4, C6, C10, C11, C38, C39, C43, C44	0.1 μF	C0402, 0.1 μF, 50 V, X5R	Murata	GRM155R61H104KE19D
C5, C7, C8, C9, C37, C40, C50, C51	1 μF	C0402, 1 μF, 16 V, X5R	Taiyo Yuden	EMK105BJ105KV-F
C12 to C19	DNP	C0402, DNP	Not applicable	Not applicable
C20 to C28	4.7 nF	C0402, 4.7 nF, 50 V, X7R	Murata	GRT155R71H472KE01D
C29 to C32	DNP	C0603, DNP	Not applicable	Not applicable
C33 to C36	470 pF	C0402, 470 pF, 50 V, C0G/NP0	Murata	GRM1555C1H471JA01D
C41, C42, C45	10 μF	C0805, 10 μF, 10 V, X7R	Würth Elektronik	885012207026
C46 to C49	4n7	C1812, 4.7 nF, 2 kV, X7R	Yageo	1812GC472KAZ1A
D1 to D9	33 V	Diode, TVS bipolar, 33 V, 400 W	STMicroelectronics	SMAJ33CA
D10 to D13	10 V	Diode, TVS bipolar, 10 V, 400 W	STMicroelectronics	SMAJ10CA
D14	5 V	Diode, TVS unipolar, 36 V, 400 W	STMicroelectronics	SMAJ5.0A
D15		Diode, Schottky, 30 V, 0.5 A, SOD123	Diodes, Inc.	B0530W-7-F
D16		Diode, Schottky, 30 V, 0.5 A, SOD123	Diodes, Inc.	B0530W-7-F
ERR	Red	Light emitting diode (LED), 0603, red	Osram	LSQ976-Z
F1 to F4	50 mA	Fuse, 50 mA, 30 V, 10 A maximum	Bourns	MF-USMF005-2
J1 to J3		Connector, header, 90°, 5 position, 3.81 mm	Phoenix Contact	MC 1.5/ 5-G-3.81
J4		3.81 mm pitch	Not applicable	Not applicable
J5	DNP	1.25-MS3, ring tongue terminal, M3, No. 5, 16 AWG, 1.65 mm ²	JST	1.25-MS3
J6		Power socket block, 3-way, 3.81 mm pitch	Phoenix Contact	MC1.5/3-G-3.81
J7		Header, R/A, 3.81 mm, 3-way	Phoenix Contact	MC 1.5/ 3-G-3.81
J8		120-way connector, 0.6 mm pitch	Hirose	FX8-120S-SV(21)
J10		7-pin inline header, 100 mil centers	Würth Elektronik	61300711121
LED	Red	LED, 0603, red	Osram	LSQ976-Z
LK1, LK2		2-pin (0.1") header and shorting shunt	Harwin	M20-9990246
LK3	B	3-pin (3x1) 0.1", Header B	Harwin	M20-9990346 M7566-05
PWR	Green	LED, green, surface mount device (SMD), 20 mA, 2.1 V, 566 nm	Vishay	TLMP1100-GS08
R1, R49	4.7 kΩ	Resistor, 4.7 kΩ, 0.063 W, 1%, 0402	Multicomp	MCWR04X4701FTL
R2	100 kΩ	Resistor, 100 kΩ, 0.063 W, 1%, 0402	Multicomp	MC00625W04021100K
R3	2.2 kΩ	Resistor, 2.2 kΩ, 0.063 W, 1%, 0402	Multicomp	MC00625W040212K2
R4	100 kΩ	Resistor, 100 kΩ, 0.063 W, 1%, 0402	Multicomp	MC00625W04021100K
R5 to R7	0 Ω	Resistor, 0402, 1%, 0 Ω	Multicomp	MC00625W040210R
R8 to R15	DNP	Resistor, DNP, 0402	Multicomp	MC00625W040211K
R16 to R24	180 Ω	Resistor, 180 Ω, 0.1 W, 1%, 0603	Multicomp	MCWR06X1800FTL
R25 to R28	180 Ω	Resistor, 180 Ω, 0.1 W, 1%, 0805	Panasonic	ERJ-P06J181V
R29 to R36	33 Ω	Resistor, 33 Ω, 0.063 W, 1%, 0402	Multicomp	MC00625W0402133R
R37	DNP	Resistor, DNP, 0402	Not applicable	Not applicable
R38	14 kΩ	Resistor, 14 kΩ, 0.063 W, 1%, 0402	Multicomp	MC00625W0402114K
R39	16.9 kΩ	Resistor, 16.9 kΩ, 0.063 W, 1%, 0402	Multicomp	MC00625W0402116K9
R40	10 kΩ	Resistor, 10 kΩ, 0.063 W, 1%, 0402	Multicomp	MC00625W0402110K
R41, R42	4.7 MΩ	Resistor, 4.7 MΩ, 0.5 W, 5%, 2010	BOURNS	CHV2010-JW-475ELF
R43	1 kΩ	Resistor, 1 kΩ, 0.063 W, 1%, 0402	Multicomp	MC00625W040211K

Reference Designator	Value	Description	Manufacturer	Part Number
R44	100 kΩ	Resistor, 100 kΩ, 0.063 W, 1%, 0402	Multicomp	MC00625W04021 100K
R45	DNP	Resistor, DNP, 0402	Not applicable	Not applicable
R46 to R48	100 kΩ	Resistor, 100 kΩ, 0.063 W, 1%, 0402	Multicomp	MC00625W04021 100K
U1		±10 V and 0 mA to 20 mA, analog front end for industrial automation systems	Analog Devices, Inc.	AD4112SDZ
U2	2.5 V	2.5 V voltage reference, ±4 ppm/°C ± 0.04%	Analog Devices, Inc.	ADR4525ARZ
U3		Digital isolator, 4-channel, <i>isoPower</i>	Analog Devices, Inc.	ADUM5411BRSZ
U4		32 kb I ² C serial EEPROM	Microchip	24LC32A-I/MS
Y1	16 MHZ	Miniature crystal, SMD	Epson Toyocom	FA-20H, 16 MHZ, 10 ppm

I²C refers to a communications protocol originally developed by Philips Semiconductors (now NXP Semiconductors).



ESD Caution

ESD (electrostatic discharge) sensitive device. Charged devices and circuit boards can discharge without detection. Although this product features patented or proprietary protection circuitry, damage may occur on devices subjected to high energy ESD. Therefore, proper ESD precautions should be taken to avoid performance degradation or loss of functionality.

Legal Terms and Conditions

By using the evaluation board discussed herein (together with any tools, components documentation or support materials, the "Evaluation Board"), you are agreeing to be bound by the terms and conditions set forth below ("Agreement") unless you have purchased the Evaluation Board, in which case the Analog Devices Standard Terms and Conditions of Sale shall govern. Do not use the Evaluation Board until you have read and agreed to the Agreement. Your use of the Evaluation Board shall signify your acceptance of the Agreement. This Agreement is made by and between you ("Customer") and Analog Devices, Inc. ("ADI"), with its principal place of business at One Technology Way, Norwood, MA 02062, USA. Subject to the terms and conditions of the Agreement, ADI hereby grants to Customer a free, limited, personal, temporary, non-exclusive, non-sublicensable, non-transferable license to use the Evaluation Board FOR EVALUATION PURPOSES ONLY. Customer understands and agrees that the Evaluation Board is provided for the sole and exclusive purpose referenced above, and agrees not to use the Evaluation Board for any other purpose. Furthermore, the license granted is expressly made subject to the following additional limitations: Customer shall not (i) rent, lease, display, sell, transfer, assign, sublicense, or distribute the Evaluation Board; and (ii) permit any Third Party to access the Evaluation Board. As used herein, the term "Third Party" includes any entity other than ADI, Customer, their employees, affiliates and in-house consultants. The Evaluation Board is NOT sold to Customer; all rights not expressly granted herein, including ownership of the Evaluation Board, are reserved by ADI. CONFIDENTIALITY. This Agreement and the Evaluation Board shall all be considered the confidential and proprietary information of ADI. Customer may not disclose or transfer any portion of the Evaluation Board to any other party for any reason. Upon discontinuation of use of the Evaluation Board or termination of this Agreement, Customer agrees to promptly return the Evaluation Board to ADI. ADDITIONAL RESTRICTIONS. Customer may not disassemble, decompile or reverse engineer chips on the Evaluation Board. Customer shall inform ADI of any occurred damages or any modifications or alterations it makes to the Evaluation Board, including but not limited to soldering or any other activity that affects the material content of the Evaluation Board. Modifications to the Evaluation Board must comply with applicable law, including but not limited to the RoHS Directive. TERMINATION. ADI may terminate this Agreement at any time upon giving written notice to Customer. Customer agrees to return to ADI the Evaluation Board at that time. LIMITATION OF LIABILITY. THE EVALUATION BOARD PROVIDED HEREUNDER IS PROVIDED "AS IS" AND ADI MAKES NO WARRANTIES OR REPRESENTATIONS OF ANY KIND WITH RESPECT TO IT. ADI SPECIFICALLY DISCLAIMS ANY REPRESENTATIONS, ENDORSEMENTS, GUARANTEES, OR WARRANTIES, EXPRESS OR IMPLIED, RELATED TO THE EVALUATION BOARD INCLUDING, BUT NOT LIMITED TO, THE IMPLIED WARRANTY OF MERCHANTABILITY, TITLE, FITNESS FOR A PARTICULAR PURPOSE OR NON-INFRINGEMENT OF INTELLECTUAL PROPERTY RIGHTS. IN NO EVENT WILL ADI AND ITS LICENSORS BE LIABLE FOR ANY INCIDENTAL, SPECIAL, INDIRECT, OR CONSEQUENTIAL DAMAGES RESULTING FROM CUSTOMER'S POSSESSION OR USE OF THE EVALUATION BOARD, INCLUDING BUT NOT LIMITED TO LOST PROFITS, DELAY COSTS, LABOR COSTS OR LOSS OF GOODWILL. ADI'S TOTAL LIABILITY FROM ANY AND ALL CAUSES SHALL BE LIMITED TO THE AMOUNT OF ONE HUNDRED US DOLLARS (\$100.00). EXPORT. Customer agrees that it will not directly or indirectly export the Evaluation Board to another country, and that it will comply with all applicable United States federal laws and regulations relating to exports. GOVERNING LAW. This Agreement shall be governed by and construed in accordance with the substantive laws of the Commonwealth of Massachusetts (excluding conflict of law rules). Any legal action regarding this Agreement will be heard in the state or federal courts having jurisdiction in Suffolk County, Massachusetts, and Customer hereby submits to the personal jurisdiction and venue of such courts. The United Nations Convention on Contracts for the International Sale of Goods shall not apply to this Agreement and is expressly disclaimed.