

PART NUMBER	REVISION	DESCRIPTION	FEED TYPE
2150042-1	F	FINE CRIMP HEIGHT ADJUST	MECHANICAL
2150042-2	F	FINE CRIMP HEIGHT ADJUST	PNEUMATIC
7-2150042-1	F	MECHANICAL AND CRIMP TOOLING KIT	MECHANICAL
7-2150042-2	F	PNEUMATIC AND CRIMP TOOLING KIT	PNEUMATIC
7-2150042-7	A	CRIMP TOOLING KIT	-

ATLANTIC VERSION TERMINATOR INTERFACE ADAPTER

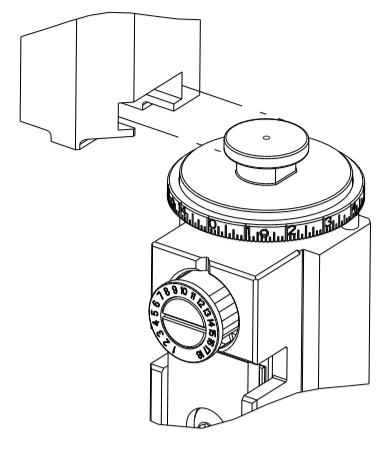

APPLICATOR DATA		
CRIMP	SIZE	TYPE
WIRE	2.79 mm [.110]	F
INSUL	4.57 mm [.180]	F
APPL INSTRUCTIONS 408-35043		

TERMINAL DATA: TE TERMINAL		TE CRIMP SPECIFICATION	
TERMINAL NAME: RECEPTACLE, FASTIN-FASTON, 250 SERIES			
WIRE STRIP LENGTH		INSULATION DIAMETER RANGE	
5.21-5.97 mm [.205-.235 IN]		Ø3.05-4.32 mm [.120-.170 IN]	
TERMINAL APPLICATION SPECIFICATION	114-2025	-	-
TERMINALS APPLIED			
TE TERMINAL	TE TERMINAL	TE TERMINAL	TE TERMINAL
152373-1	152373-2	152373-3	154935-1
63563-1	154935-4	1-154935-1	1-154935-2
60634-1			

TERMINAL DATA: TE TERMINAL		TE CRIMP SPECIFICATION	
TERMINAL NAME: RECEPTACLE, FASTIN-FASTON, 250 SERIES			
WIRE STRIP LENGTH		INSULATION DIAMETER RANGE	
5.21-5.97 mm [.205-.235 IN]		Ø3.05-4.32 mm [.120-.170 IN]	
TERMINAL APPLICATION SPECIFICATION	114-2025	-	-
TERMINALS APPLIED			
TE TERMINAL	TE TERMINAL	TE TERMINAL	TE TERMINAL
42281-1	42281-2		

WIRE SIZE	CRIMP HEIGHT mm [INCH]	CRIMP HEIGHT REFERENCE SETTING
14 AWG	1.85 +/- 0.05 [.073 +/- .002]	4.5
16 AWG	1.63 +/- 0.05 [.064 +/- .002]	7.0
18 AWG	1.47 +/- 0.05 [.058 +/- .002]	8.6

WIRE SIZE	CRIMP HEIGHT mm [INCH]	CRIMP HEIGHT REFERENCE SETTING
14 AWG	1.78 +/- 0.05 [.070 +/- .002]	5.2
16 AWG	1.55 +/- 0.05 [.061 +/- .002]	7.7
1.0mm ²	1.40 +/- 0.05 [.055 +/- .002]	9.3
18 AWG	1.40 +/- 0.05 [.055 +/- .002]	9.3

***WARNING**
ON INSTALLATION, SET WIRE DISC TO CRIMP HEIGHT REFERENCE SETTING FOR LARGEST WIRE SIZE. CRIMP HEIGHT REFERENCE SETTINGS GREATER THAN THE VALUE SHOWN MAY CAUSE DAMAGE TO THE CRIMP TOOLING. REFER TO THE INSTRUCTION SHEET FOR PROPER SETUP AND ADJUSTMENTS.

- RECOMMENDED SPARE PARTS
- REFER TO SUPPLIED INSTRUCTION SHEET FOR CLEANING, LUBRICATION AND STORAGE OF APPLICATOR.
- APPLY PART NUMBER 2-23419-6 LOCTITE TO THREADS OF ITEM 242. APPLY PART NUMBER 1-23419-5 LOCTITE TO THREADS OF ITEM 180.
- CRIMP HEIGHT REFERENCE SETTING WAS THE SETTING USED WHEN THE APPLICATOR WAS QUALIFIED AT THE FACTORY. ADJUSTMENT MAY BE NECESSARY WHEN RUNNING APPLICATOR IN THE FIELD.
- TERMINAL LUBRICANT IS RECOMMENDED.
- 6. UNLESS SPECIFIED OTHERWISE TORQUE VALUES SHALL BE USED PER DOCUMENT, 101-35000.
- THIS CRIMP PARAMETER IS PROVIDED TO MEET A CUSTOM AND UNIQUE CUSTOMER REQUIREMENT. IT HAS BEEN EVALUATED AND IS CONDITIONALLY SPECIFIED BY TE CONNECTIVITY. THIS CUSTOMIZED CRIMP PARAMETER IS NOT LISTED AS AN APPROVED APPLICATION WITHIN A TE CONNECTIVITY APPLICATION SPECIFICATION; HOWEVER, IT HAS BEEN VALIDATED ACCORDING TO TE CONNECTIVITY SPECIFICATIONS 109-18079 (TEST GROUP 1) AND 114-18022. **TE CONNECTIVITY EXPRESSLY DISCLAIMS ANY AND ALL WARRANTIES THAT THE PRODUCT WILL PERFORM SIMILARLY TO VALIDATED AND APPROVED APPLICATIONS, AS STATED WITHIN TE CONNECTIVITY APPLICATION SPECIFICATIONS, INCLUDING BUT NOT LIMITED TO IMPLIED WARRANTIES OF MERCHANTABILITY OR FITNESS FOR PARTICULAR PURPOSE.** AS SUCH, IT IS HIGHLY RECOMMENDED THAT THE CUSTOMER PERFORM FURTHER DETAILED EVALUATION TO ASSESS PRODUCT PERFORMANCE IN THE SPECIFIC APPLICATION.

REVISIONS					
P	LTN	DESCRIPTION	DATE	OWN	APPD
D		ECR-18-015548	30SEP2018	TB	TE
E		ECR-19-013225	22AUG2019	TB	RR
E1		ECR-19-015850	11OCT2019	FZ	TE
F		ECR-22-151190	01SEP2022	FJ	JAH

-	1	-	1	-	2119641-1	FEED CAM, AIR FEED	248	
-	1	1	1	1	2119082-9	CAM, SNAIL, INSULATION ADJUSTMENT	244	
-	1	1	1	1	2079764-1	WASHER, WAVE SPRING, CREST-TO-CREST	243	
-	1	1	1	1	2119083-1	RETAINER, INSULATION DIAL	242	
-	-	1	-	1	2119580-1	MECHANICAL FEED ASSEMBLY	239	
-	1	-	1	-	2844940-3	AIR FEED MODULE	238	
-	1	1	1	1	1-18028-0	WASHER, FLAT, REG M8	192	
-	1	1	1	1	1-1976055-4	STANDOFF, HOLD-DOWN	180	
-	1	1	1	1	6-9931111-6	PIN, SLOTTED SPRING 3.0 X 14.0	177	
-	1	1	1	1	8-22280-7	SPRING, COMPRESSION	176	
-	1	1	1	1	1752353-2	GUIDE PIN,HOLDDOWN	175	
-	1	1	1	1	1901680-2	GUIDE PIN,HOLDDOWN	174	
-	REF	REF	REF	REF	994970-2	COUNTER, MAGNETIC	164	
-	1	1	1	1	2119955-2	ASSY, LUBRICATOR, END FEED	84	
-	1	1	1	1	1-455888-1	SPACER, CRIMPER	82	
-	1	1	1	1	1803607-4	DOCUMENTATION PACKAGE	71	
-	2	2	2	2	2-18032-2	SCR, SET, FLT PNT, M3 X 10.0	70	
-	1	1	1	1	2119740-1	TAG, IDENTIFICATION	67	
-	2	2	2	2	2168078-1	SCREW, DRIVE, RH, RoHS, 2 x .188	66	
-	1	1	1	1	1901681-5	HOLDDOWN, TERMINAL	65	
-	2	2	2	2	2168400-8	SHCS, LOW HEAD, RoHS, M4 X 16	64	
-	1	1	1	1	2168083-2	SCR, SKT HD CAP, RoHS, M4 X 8.0	60	
-	1	1	1	1	5-18022-5	SCR, HEX HD CAP, M4 X 6.0	59	
-	-	1	-	1	2063961-1	FEED FINGER	58	
-	3	3	3	3	2168400-4	SHCS, LOW HEAD, RoHS, M4 X 8	57	
-	2	2	2	2	1-2168083-0	SCR, SKT HD CAP, RoHS, M4 X 10	56	
-	2	2	2	2	5018030-1	NUT, HEX, REG, RoHS, M3	54	
-	2	2	2	2	986965-8	NUT, LOCK, HEX, TORQUE (M4)	53	
-	1	1	1	1	1-5018030-0	NUT, HEX, REG, RoHS, M3.5	52	
-	1	-	1	-	2063961-1	FEED FINGER	51	
-	1	2	1	2	18023-9	SCR, SKT HD CAP M4 X 6.0	49	
-	-	1	-	1	2119652-1	FEED CAM, PRE FEED	48	
-	-	1	-	1	2119653-1	FEED CAM, POST FEED	47	
-	1	1	1	1	2119655-5	APPLICATOR BASIC ASSEMBLY, EF	46	
-	1	1	1	1	1803517-1	RAM ASSEMBLY, EF ATLANTIC	44	
-	1	1	1	1	1803602-1	SCR, BHSC, RoHS (M8 X 25)	41	
-	7	7	7	7	1-18028-2	WASHER, FLAT, REG M4	33	
-	2	2	2	2	2168083-9	SCR, SKT HD CAP, RoHS, M4 X 20	31	
-	2	2	2	2	2168083-2	SCR, SKT HD CAP, RoHS, M4 X 8.0	29	
-	1	1	1	1	240639-1	STRIPPER (MACHINING)	27	
-	2	2	2	2	1-2168083-5	SCR, SKT HD CAP, RoHS, M4 X 30	25	
-	1	1	1	1	1752371-3	PLATE, STRIP GUIDE	24	
-	1	1	1	1	240825-2	PLATE, STRIP HOLD DOWN	23	
-	2	2	2	2	2-22281-3	SPRING, COMPRESSION	22	
-	1	1	1	1	1803292-4	DRAG	20	
-	2	2	2	2	1901259-5	GUIDE, LOWER STRIP	18	
-	4	4	4	4	1-2079383-1	SCR, BHSC, RoHS (M6 X 12)	17	
-	1	1	1	1	1752360-1	SPACER,HOLD-DOWN	13	
-	1	1	1	1	240833-2	PLATE, REAR SHEAR	11	
-	-	-	-	-	-	-	10	
-	1	1	1	1	690495-4	PLATE, FRONT SHEAR	9	
-	1	2	2	1	1333219-3	ANVIL, COMBINATION	8	
-	1	1	1	1	1-2217206-3	BLADE, SLUG	7	
-	1	1	1	1	3-240641-5	SPACER	5	
-	1	1	1	1	238011-2	BLOCK, CRIMPER SPACER	4	
-	1	2	2	1	2119582-3	CRIMPER, INSULATION F PREMIUM	3	
-	1	1	1	1	455888-9	SPACER, CRIMPER	2	
-	1	2	2	1	1-456408-8	CRIMPER, WIRE PREMIUM	1	
-	77	72	71	2	-1	PART NO	DESCRIPTION	ITEM NO

ATLANTIC VERSION
Shown on sheets 1 of 4 & 2 of 4
(Pacific version shown on sheets 3 of 4 & 4 of 4)

DIMENSIONS:		TOLERANCES UNLESS OTHERWISE SPECIFIED:		APPROVED:		NAME:	
mm	0 PLC ±	1 PLC ±	2 PLC ±	3 PLC ±	4 PLC ±	ANGLES ±	FINISH ±
MATERIAL		WEIGHT		SCALE		SHEET	
-		-		1:1		1 OF 4	

REVISIONS				
P	LTN	DESCRIPTION	DATE	APPV
-	-	SEE SHEET 1	-	-

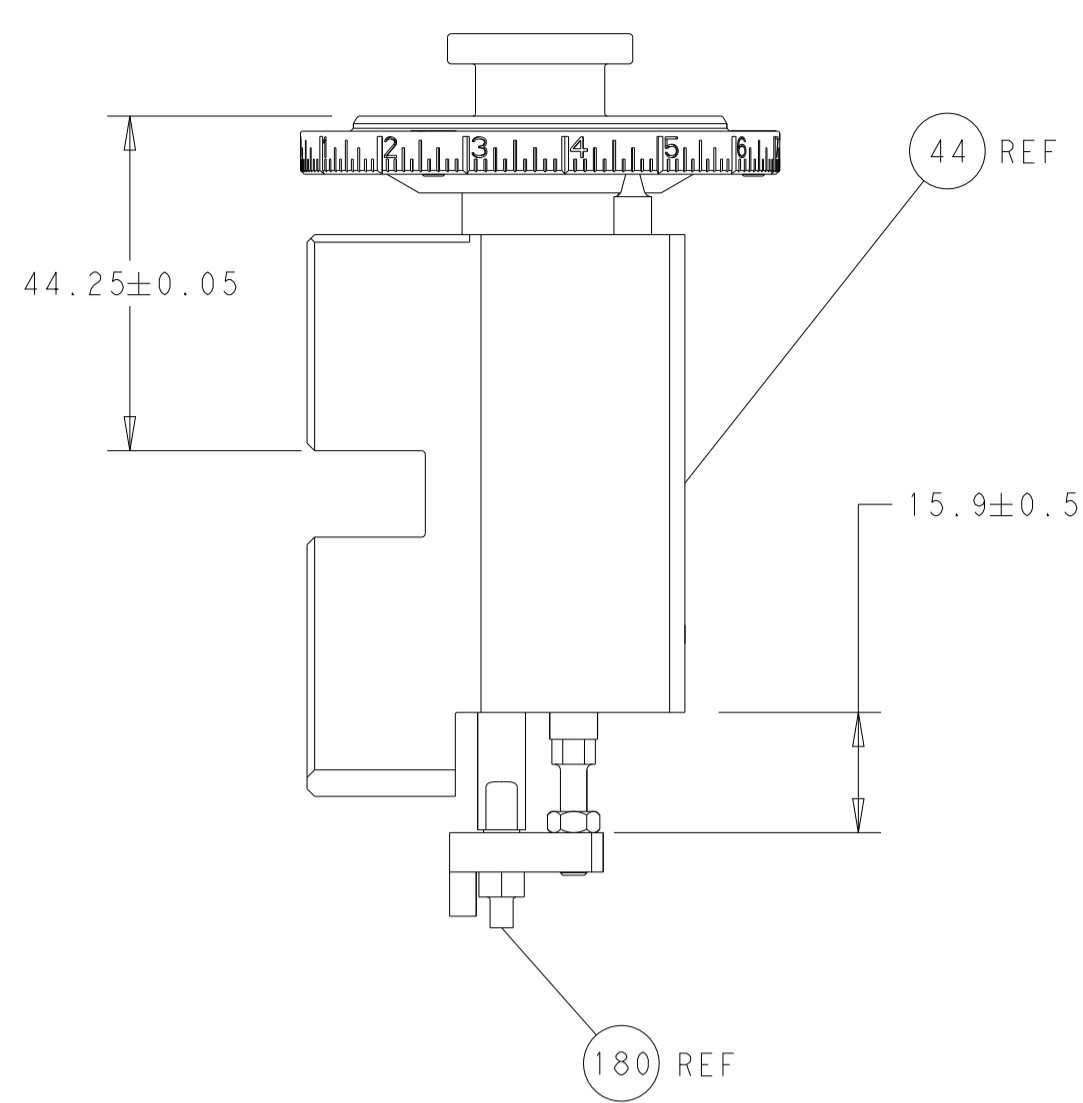

RAM AND HOLDDOWN SET-UP

FEED TYPE
MECHANICAL

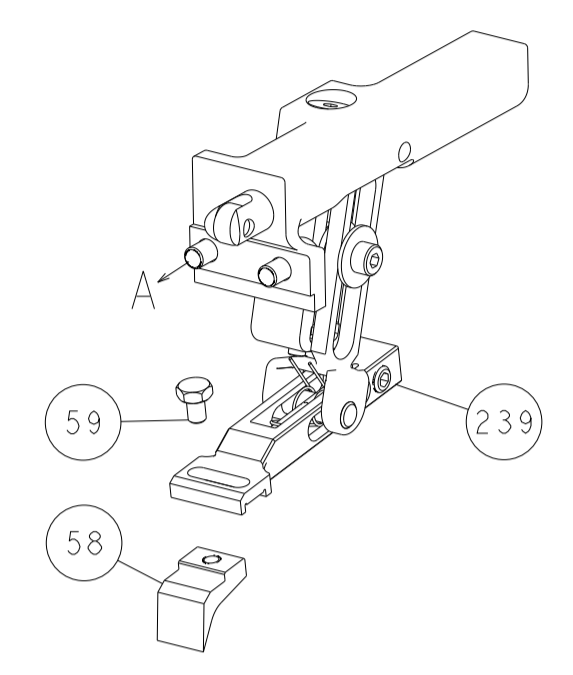

PNEUMATIC

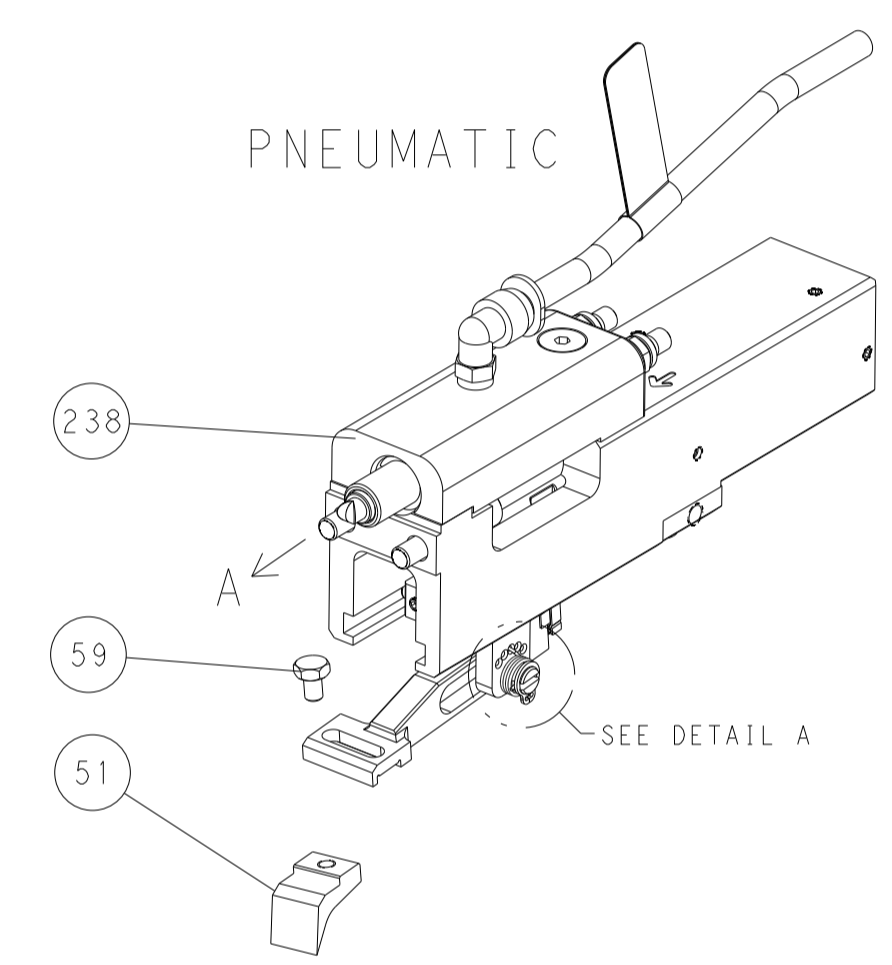

FEED SPRING
SETTING POSITION

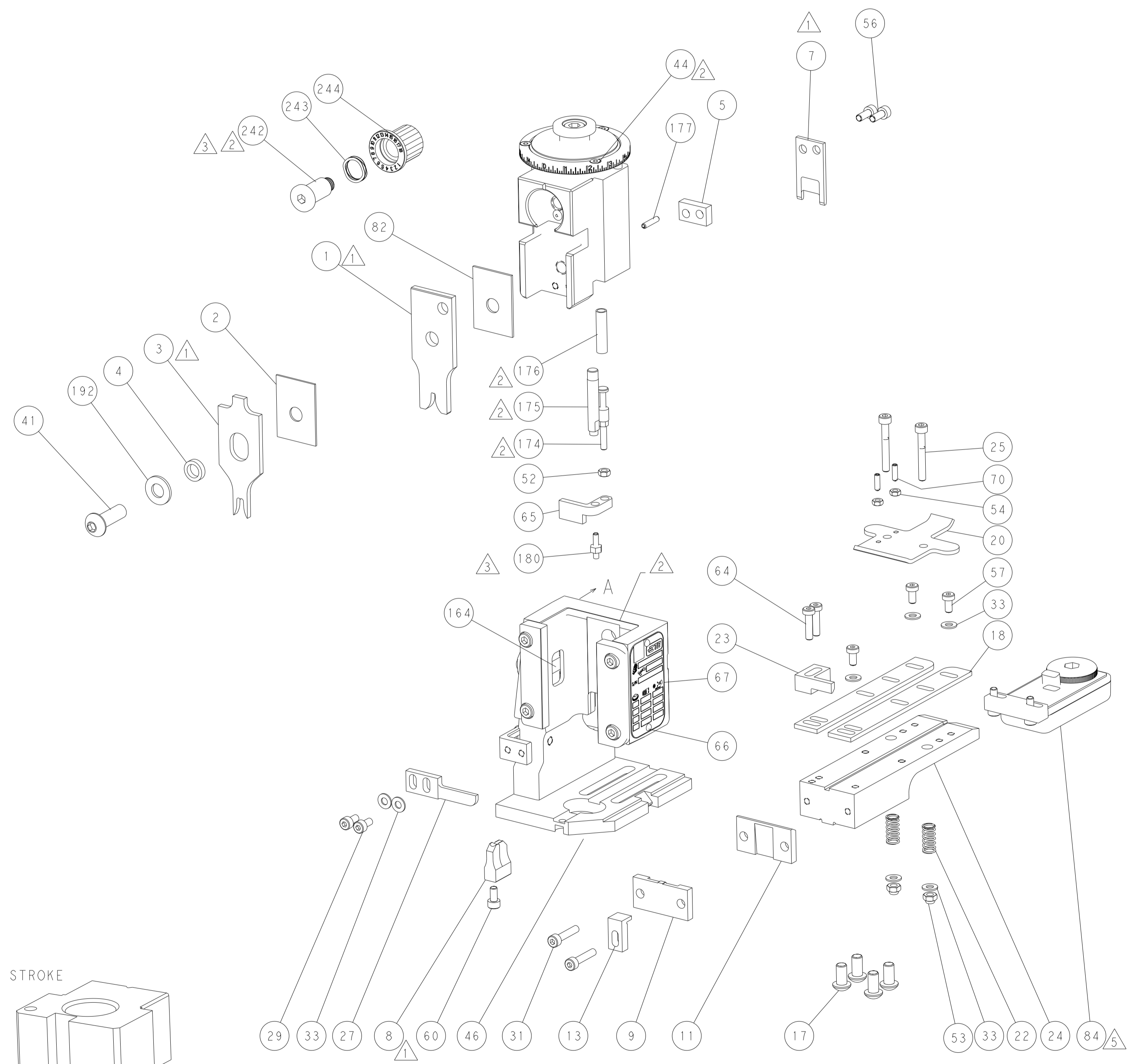
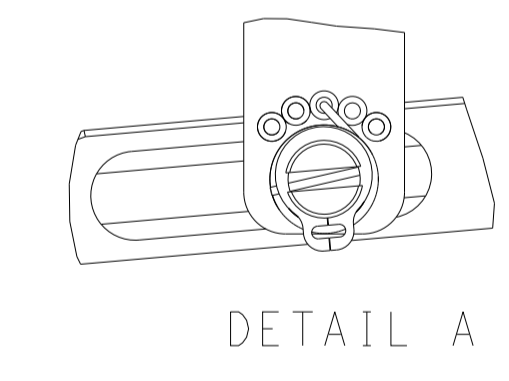

CAM POSITIONS

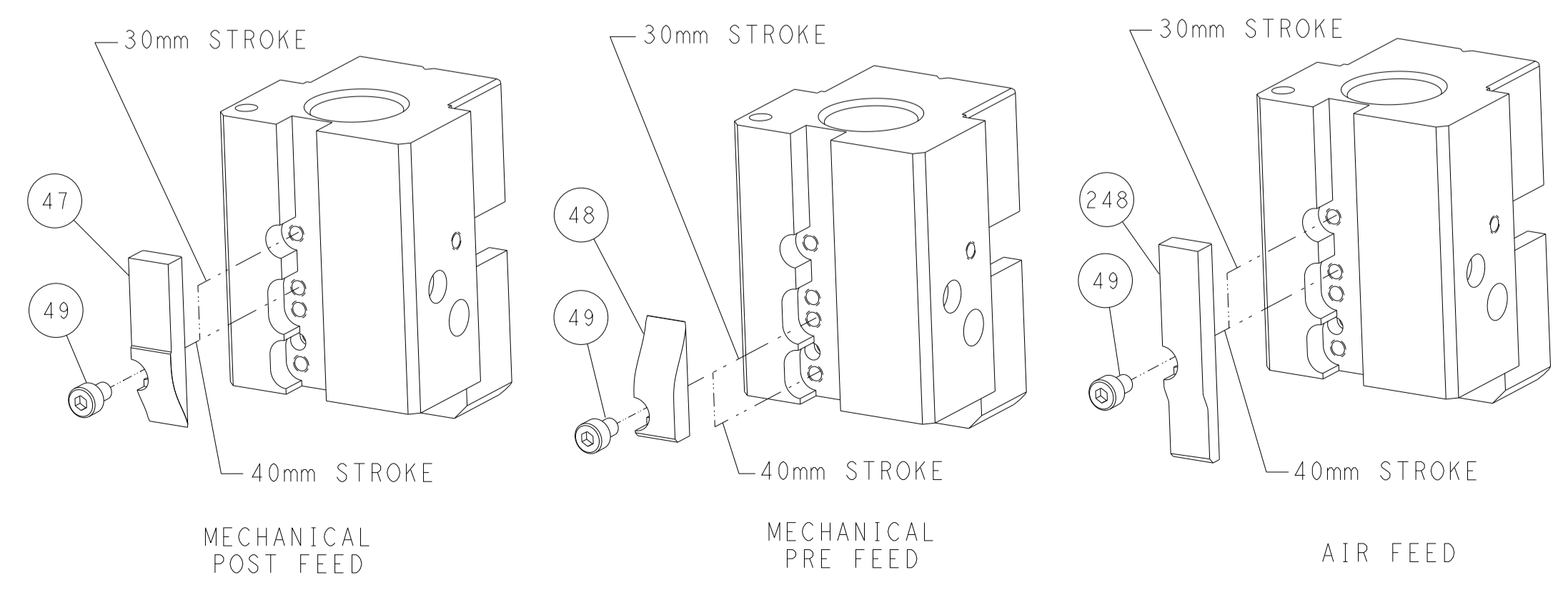

ATLANTIC VERSION
Shown on sheets 1 of 4 & 2 of 4
(Pacific version shown on sheets 3 of 4 & 4 of 4)

THIS DRAWING IS A CONTROLLED DOCUMENT.		OWN: L. ZHANG 12JAN2012	TE Connectivity
DIMENSIONS: mm		CHK: L. ZHANG 12JAN2012	
TOLERANCES UNLESS OTHERWISE SPECIFIED:		APPV: S. XI 12JAN2012	
0 PLC ± 1 PLC ± 2 PLC ± 3 PLC ± 4 PLC ± ANGLES ± FINISH ±		NAME: Ocean End Feed Applicator	
MATERIAL:		PRODUCT SPEC:	RESTRICTED TO:
		APPLICATION SPEC:	SIZE: A1
		WEIGHT:	CAGE CODE: 2150042
		Customer Accessible Production Drawing	SCALE: 1:1 SHEET 2 OF 4 REV F

PART NUMBER	REVISION	DESCRIPTION	FEED TYPE
2-2150042-1	F	FINE CRIMP HEIGHT ADJUST	MECHANICAL
2-2150042-2	F	FINE CRIMP HEIGHT ADJUST	PNEUMATIC
7-2150042-7	A	CRIMP TOOLING KIT	-

PACIFIC VERSION TERMINATOR INTERFACE ADAPTER

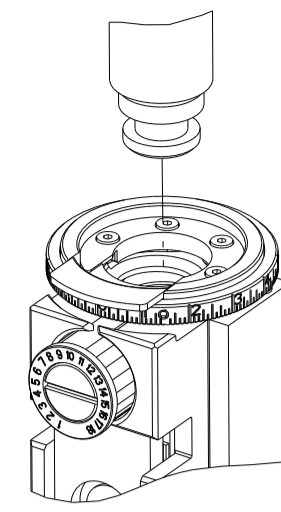

APPLICATOR DATA		
CRIMP	SIZE	TYPE
WIRE	2.79 mm [1.10]	F
INSUL	4.57 mm [1.80]	F
APPL INSTRUCTIONS 408-35043		

TERMINAL DATA: TE TERMINAL		TE CRIMP SPECIFICATION	
TERMINAL NAME: RECEPTACLE, FASTIN-FASTON, 250 SERIES			
WIRE STRIP LENGTH		INSULATION DIAMETER RANGE	
5.21-5.97 mm [1.205-.235 IN]		∅3.05-4.32 mm [1.120-.170 IN]	
TERMINAL APPLICATION SPECIFICATION	114-2025	-	-
TERMINALS APPLIED			
TE TERMINAL	TE TERMINAL	TE TERMINAL	TE TERMINAL
152373-1	152373-2	152373-3	154935-1
63563-1	154935-4	1-154935-1	1-154935-2
60634-1			

TERMINAL DATA: TE TERMINAL		TE CRIMP SPECIFICATION	
TERMINAL NAME: RECEPTACLE, FASTIN-FASTON, 250 SERIES			
WIRE STRIP LENGTH		INSULATION DIAMETER RANGE	
5.21-5.97 mm [1.205-.235 IN]		∅3.05-4.32 mm [1.120-.170 IN]	
TERMINAL APPLICATION SPECIFICATION	114-2025	-	-
TERMINALS APPLIED			
TE TERMINAL	TE TERMINAL	TE TERMINAL	TE TERMINAL
42281-1	42281-2		

WIRE SIZE	CRIMP HEIGHT mm [INCH]	CRIMP HEIGHT REFERENCE SETTING
14 AWG	1.85+/-0.05 [0.073+/-0.002]	4.5
16 AWG	1.63+/-0.05 [0.064+/-0.002]	7.0
18 AWG	1.47+/-0.05 [0.058+/-0.002]	8.6

WIRE SIZE	CRIMP HEIGHT mm [INCH]	CRIMP HEIGHT REFERENCE SETTING
14 AWG	1.78+/-0.05 [0.070+/-0.002]	5.2
16 AWG	1.55+/-0.05 [0.061+/-0.002]	7.7
1.0mm ²	1.40+/-0.05 [0.055+/-0.002]	9.3
18 AWG	1.40+/-0.05 [0.055+/-0.002]	9.3

REVISIONS				
P	LTN	DESCRIPTION	DATE	OWN
-	-	SEE SHEET 1	-	-

-	1	1	2119082-9	CAM, SNAIL, INSULATION ADJUSTMENT	244
-	1	1	2079764-1	WASHER, WAVE SPRING, CREST-TO-CREST	243
	-	1	2119083-1	RETAINER, INSULATION DIAL	242
-	-	1	2119580-1	MECHANICAL FEED ASSEMBLY	239
-	1	-	2844940-3	AIR FEED MODULE	238
-	1	1	1-18028-0	WASHER, FLAT, REG M8	192
-	4	4	2079383-9	SCR, BHSC, RoHS (M6 X 20)	186
	-	1	1-1976055-4	STANDOFF, HOLD-DOWN	180
-	1	1	6-993111-6	PIN, SLOTTED SPRING 3.0 X 14.0	177
-	1	1	8-22280-7	SPRING, COMPRESSION	176
-	1	1	1752353-2	GUIDE PIN,HOLDDOWN	175
-	1	1	1901680-2	GUIDE PIN,HOLDDOWN	174
-	REF	REF	994970-2	COUNTER, MAGNETIC	164
-	1	-	2119641-2	FEED CAM, AIR FEED	152
-	-	1	2168083-8	SCR, SKT HD CAP, RoHS, M4 X 16	144
-	-	1	2119653-2	FEED CAM, POST FEED	142
-	1	1	2119655-6	APPLICATOR BASIC ASSEMBLY, EF	141
	-	1	1803518-1	RAM ASSEMBLY, EF PACIFIC	140
-	1	1	2119955-2	ASSY, LUBRICATOR, END FEED	84
-	1	1	1-455888-1	SPACER, CRIMPER	82
-	1	1	1803607-4	DOCUMENTATION PACKAGE	71
-	2	2	2-18032-2	SCR, SET, FLT PNT, M3 X 10.0	70
-	1	1	2119740-1	TAG, IDENTIFICATION	67
-	2	2	2168078-1	SCREW, DRIVE, RH, RoHS, 2 x .188	66
-	1	1	1901681-5	HOLDDOWN, TERMINAL	65
-	2	2	2168400-8	SHCS, LOW HEAD, RoHS, M4 X 16	64
-	1	1	5-18022-5	SCR, HEX HD CAP, M4 X 6.0	59
-	-	1	2063961-1	FEED FINGER	58
-	3	3	2168400-4	SHCS, LOW HEAD, RoHS, M4 X 8	57
-	2	2	1-2168083-0	SCR, SKT HD CAP, RoHS, M4 X 10	56
-	2	2	5018030-1	NUT, HEX, REG, RoHS, M3	54
-	2	2	986965-8	NUT, LOCK, HEX, TORQUE (M4)	53
-	1	1	1-5018030-0	NUT, HEX, REG, RoHS, M3.5	52
-	1	-	2063961-1	FEED FINGER	51
-	1	2	18023-9	SCR, SKT HD CAP M4 X 6.0	49
-	-	1	2119652-1	FEED CAM, PRE FEED	48
-	1	1	1803602-1	SCR, BHSC, RoHS (M8 X 25)	41
-	7	7	1-18028-2	WASHER, FLAT, REG M4	33
-	2	2	2168083-9	SCR, SKT HD CAP, RoHS, M4 X 20	31
-	2	2	2168083-2	SCR, SKT HD CAP, RoHS, M4 X 8.0	29
-	1	1	240639-1	STRIPPER (MACHINING)	27
-	2	2	1-2168083-5	SCR, SKT HD CAP, RoHS, M4 X 30	25
-	1	1	1752371-3	PLATE, STRIP GUIDE	24
-	1	1	240825-2	PLATE, STRIP HOLD DOWN	23
-	2	2	2-22281-3	SPRING, COMPRESSION	22
-	1	1	1803292-4	DRAG	20
-	2	2	1901259-5	GUIDE, LOWER STRIP	18
-	1	1	1752360-1	SPACER,HOLD-DOWN	13
	-	1	240833-2	PLATE, REAR SHEAR	11
-	-	-	-	-	10
	-	1	690495-4	PLATE, FRONT SHEAR	9
	1	1	1333219-3	ANVIL, COMBINATION	8
	-	1	1-2217206-3	BLADE, SLUG	7
-	1	1	3-240641-5	SPACER	5
-	1	1	238011-2	BLOCK, CRIMPER SPACER	4
	1	1	2119582-3	CRIMPER, INSULATION F PREMIUM	3
-	1	1	455888-9	SPACER, CRIMPER	2
	1	1	1-456408-8	CRIMPER, WIRE PREMIUM	1
-	77	22	21	PART NO	DESCRIPTION
-	-	-	-	-	ITEM NO

- RECOMMENDED SPARE PARTS
- REFER TO SUPPLIED INSTRUCTION SHEET FOR CLEANING, LUBRICATION AND STORAGE OF APPLICATOR.
- APPLY PART NUMBER 2-23419-6 LOCTITE TO THREADS OF ITEM 242. APPLY PART NUMBER 1-23419-5 LOCTITE TO THREADS OF ITEM 180.
- CRIMP HEIGHT REFERENCE SETTING WAS THE SETTING USED WHEN THE APPLICATOR WAS QUALIFIED AT THE FACTORY. ADJUSTMENT MAY BE NECESSARY WHEN RUNNING APPLICATOR IN THE FIELD.
- TERMINAL LUBRICANT IS RECOMMENDED.
- 6. UNLESS SPECIFIED OTHERWISE TORQUE VALUES SHALL BE USED PER DOCUMENT, 101-35000.
- THIS CRIMP PARAMETER IS PROVIDED TO MEET A CUSTOM AND UNIQUE CUSTOMER REQUIREMENT. IT HAS BEEN EVALUATED AND IS CONDITIONALLY SPECIFIED BY TE CONNECTIVITY. THIS CUSTOMIZED CRIMP PARAMETER IS NOT LISTED AS AN APPROVED APPLICATION WITHIN A TE CONNECTIVITY APPLICATION SPECIFICATION; HOWEVER, IT HAS BEEN VALIDATED ACCORDING TO TE CONNECTIVITY SPECIFICATIONS 109-18079 (TEST GROUP 1) AND 114-18022. **TE CONNECTIVITY EXPRESSLY DISCLAIMS ANY AND ALL WARRANTIES THAT THE PRODUCT WILL PERFORM SIMILARLY TO VALIDATED AND APPROVED APPLICATIONS, AS STATED WITHIN TE CONNECTIVITY APPLICATION SPECIFICATIONS, INCLUDING BUT NOT LIMITED TO IMPLIED WARRANTIES OF MERCHANTABILITY OR FITNESS FOR PARTICULAR PURPOSE.** AS SUCH, IT IS HIGHLY RECOMMENDED THAT THE CUSTOMER PERFORM FURTHER DETAILED EVALUATION TO ASSESS PRODUCT PERFORMANCE IN THE SPECIFIC APPLICATION.

***WARNING**
ON INSTALLATION, SET WIRE DISC TO CRIMP HEIGHT REFERENCE SETTING FOR LARGEST WIRE SIZE. CRIMP HEIGHT REFERENCE SETTINGS GREATER THAN THE VALUE SHOWN MAY CAUSE DAMAGE TO THE CRIMP TOOLING. REFER TO THE INSTRUCTION SHEET FOR PROPER SETUP AND ADJUSTMENTS.

PACIFIC VERSION
Shown on sheets 3 of 4 & 4 of 4
(Atlantic version shown on sheets 1 of 4 & 2 of 4)

THIS DRAWING IS A CONTROLLED DOCUMENT.		OWN L. ZHANG 12JAN2012	TE Connectivity Ocean End Feed Applicator
DIMENSIONS: mm		CHK L. ZHANG 12JAN2012	
TOLERANCES UNLESS OTHERWISE SPECIFIED:		APVD S. XI 12JAN2012	NAME
 0 PLC ± 1 PLC ± 2 PLC ± 3 PLC ± 4 PLC ± ANGLES ± FINISH ±		PRODUCT SPEC	SIZE
MATERIAL		APPLICATION SPEC	CAGE CODE
		WEIGHT	DRAWING NO
		Customer Accessible Production Drawing	RESTRICTED TO
		SCALE 1:1	SHEET 3 OF 4
		REV F	

REVISIONS				
P	LTN	DESCRIPTION	DATE	OWN APVD
-	-	SEE SHEET 1	-	-

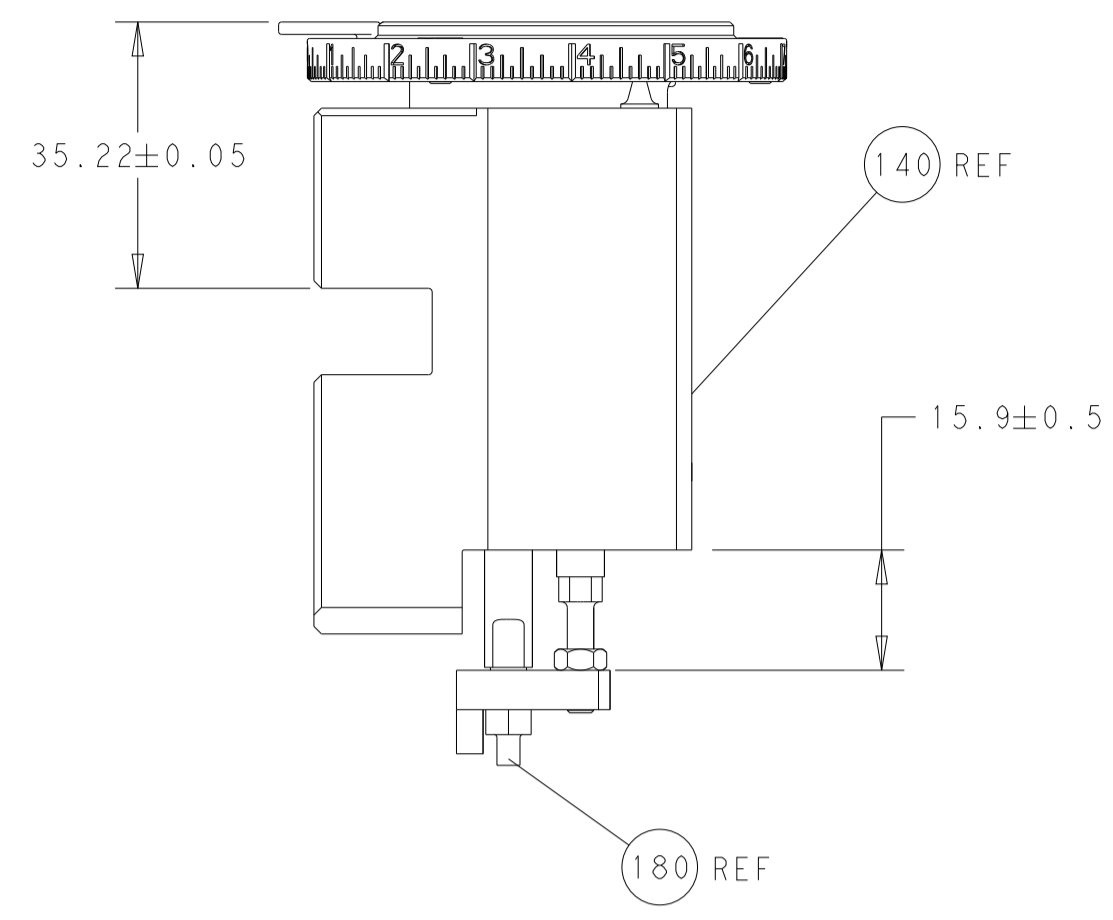

RAM AND HOLDDOWN SET-UP

FEED TYPE
MECHANICAL

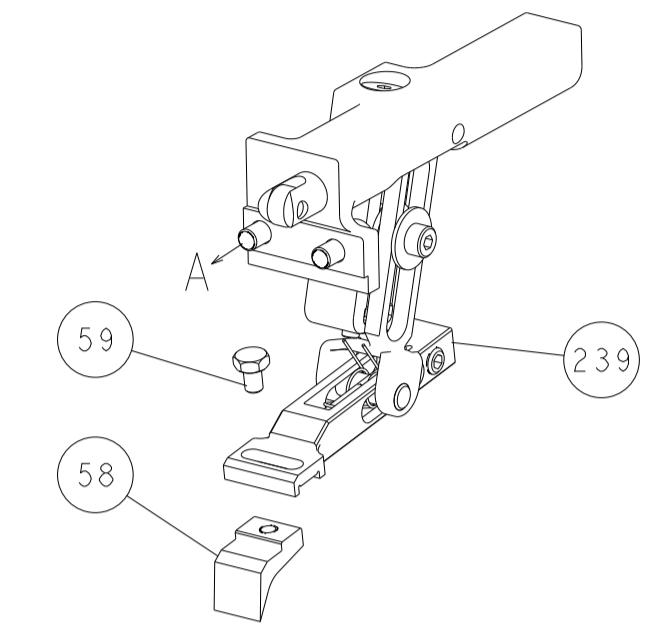

PNEUMATIC

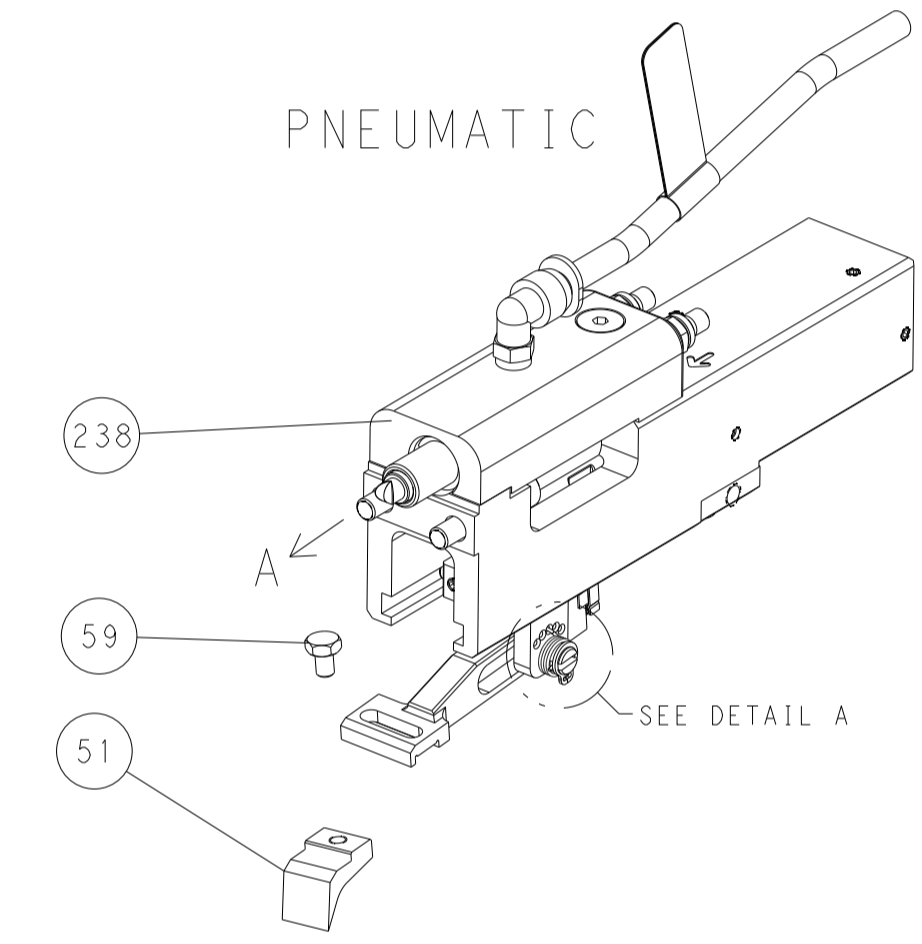

FEED SPRING
SETTING POSITION

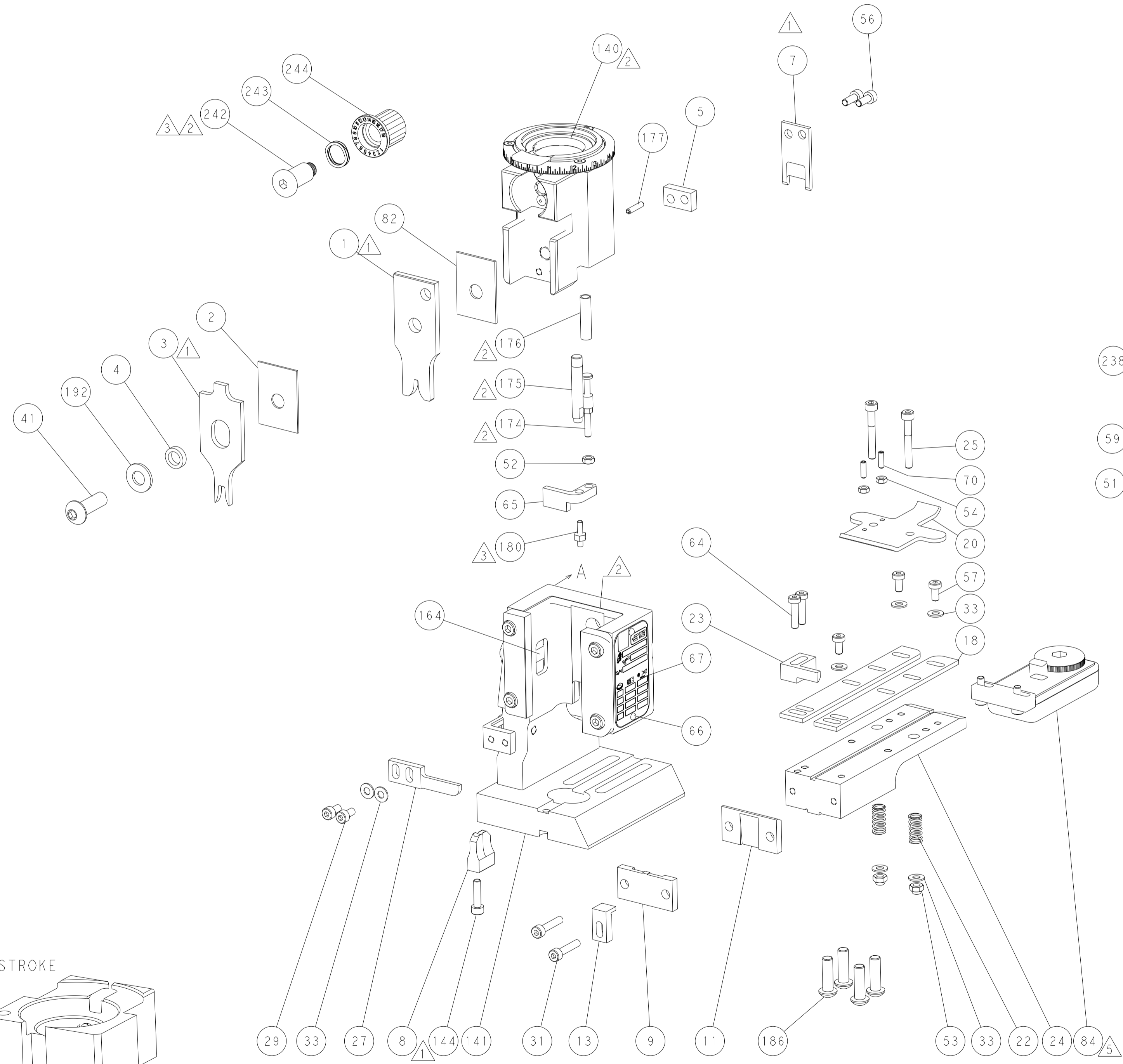
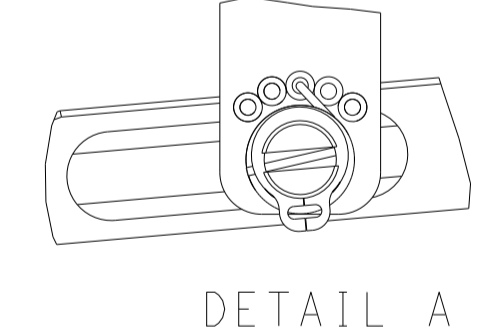

CAM POSITIONS

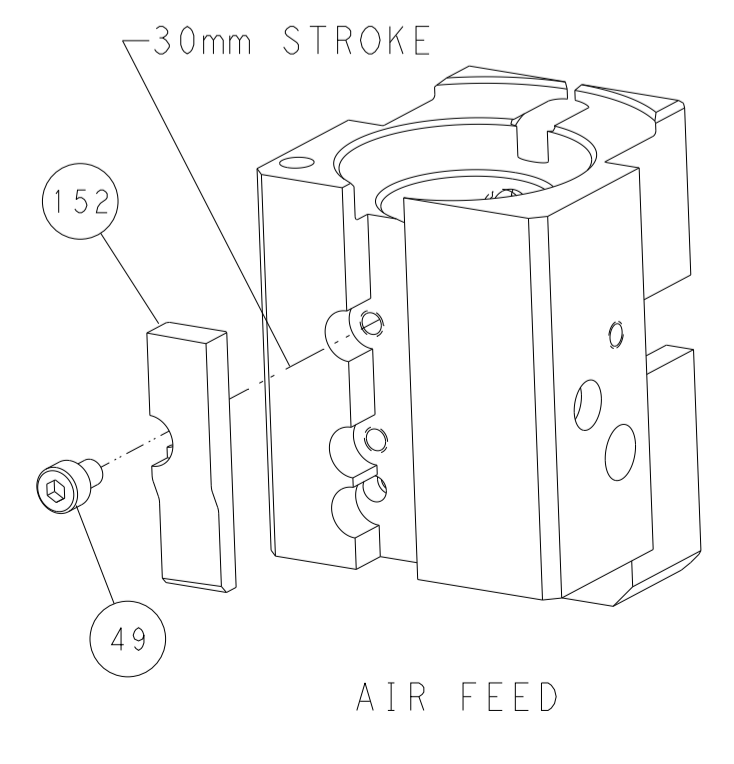
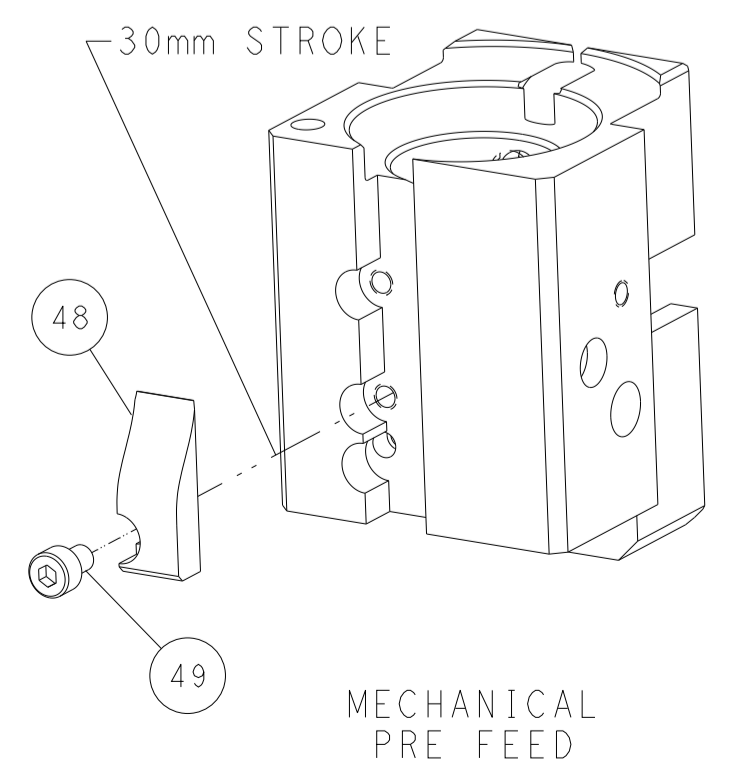
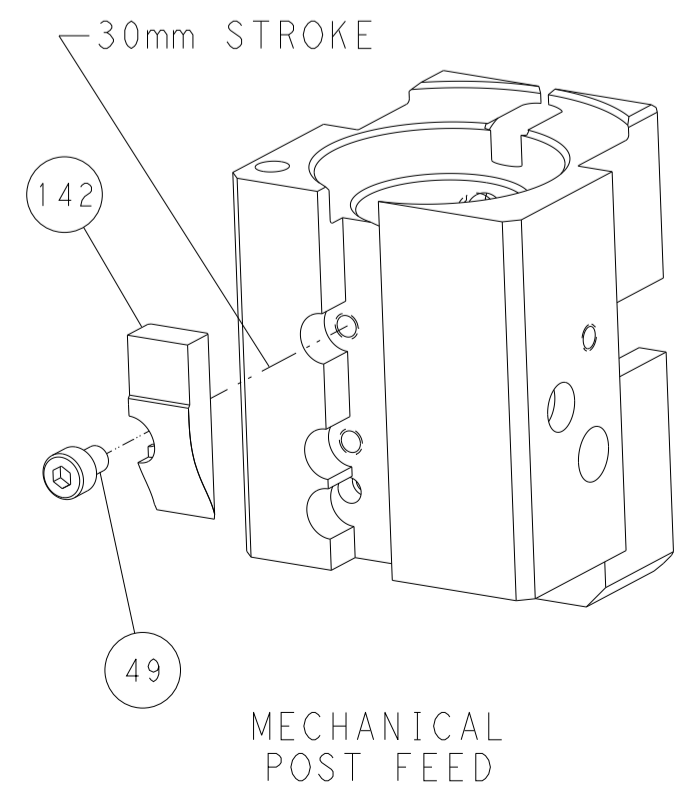

PACIFIC VERSION
 Shown on sheets 3 of 4 & 4 of 4
 (Atlantic version shown on sheets 1 of 4 & 2 of 4)

THIS DRAWING IS A CONTROLLED DOCUMENT.		OWN: L. ZHANG 12JAN2012	TE Connectivity
DIMENSIONS: mm		CHK: L. ZHANG 12JAN2012	
TOLERANCES UNLESS OTHERWISE SPECIFIED:		APVD: S. XI 12JAN2012	
0 PLC ± 1 PLC ± 2 PLC ± 3 PLC ± 4 PLC ± ANGLES ± FINISH ±		NAME: Ocean End Feed Applicator	
MATERIAL: -		SIZE: A100779	DRAWING NO: C=2150042
Customer Accessible Production Drawing		SCALE: 1:1	SHEET 4 OF 4 REV F