

Full Color .35mm Height Chip LED

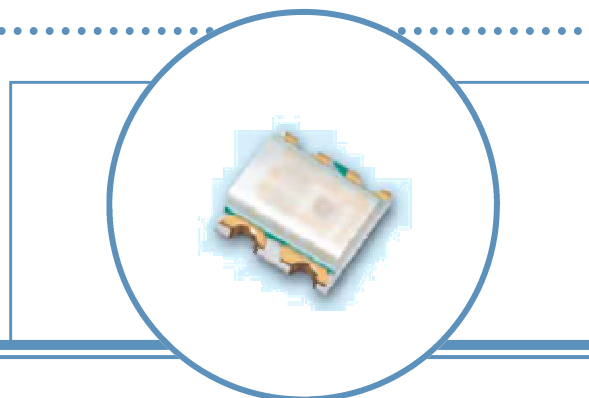

OVSTKGBBCR9

- Surface mount device packaged in 8mm tape on 7" diameter reel
- Compatible with automatic placement equipment
- Compatible with infrared and vapor phase reflow solder process
- Low profile, full color device
- Pb-free
- Dimensions: 1.6 x 1.6 x 0.35mm



The OVSTKGBBCR9 is a full color .35mm height chip LED that is much smaller than lead frame type components and enables smaller board size, higher packing density, reduced storage space, and smaller equipment to be obtained. This low-profile, multi-color plus white device is ideal for miniature applications.

Applications

- Automotive: Back Lighting in Dashboard and Switch
- Telecommunications: Indicator and Backlighting in Telephone and Fax
- Flat Backlight for LCDs, Membrane Switches, and Symbols
- Personal/Portable Appliances: Mobile Phones, Pagers, Audio/Video Players, and GPS

Part Number	Chip			Lens Color
	Type	Material	Emitted Color	
OVSTKGBBCR9	K	AlInGaN	Yellow-Orange 605nm	Water Clear
	G	InGaN	Green 525nm	
	B	InGaN	Blue 470nm	

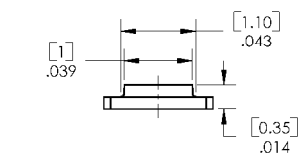
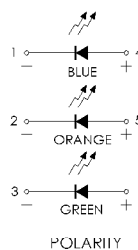
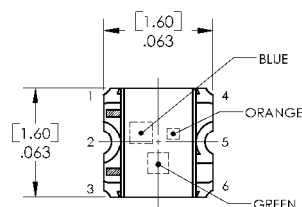

FOR REFLOW SOLDERING PURPOSES

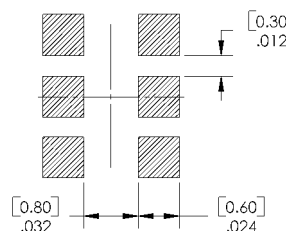
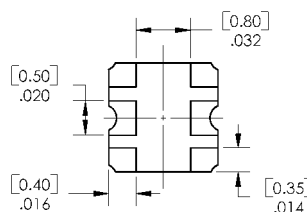

DIMENSIONS ARE IN INCHES AND [MILLIMETERS].



Full Color .35mm Height Chip LED

OVSTKGBBCR9



Absolute Maximum Ratings

T_A = 25° C unless otherwise noted

Reverse Voltage	5V
Forward Current	K:25 mA G:25 mA B:25 mA
Operating Temperature	-40 ~ +85°C
Storage Temperature	-40 ~ +90°C
Soldering Temperature	260°C (for 5 seconds)
Electrostatic Discharge	K:2000V G:150V B:150V
Power Dissipation	K:60 mW G:110 mW B:110 mW
Peak Forward Current (Duty 1/10 @ 1KHz)	K:60 mA G:100 mA B:100 mA

Electrical Characteristics

T_A = 25° C unless otherwise noted

SYMBOL	PARAMETER		MIN	TYP	MAX	UNITS	CONDITIONS
I _v	Luminous Intensity	K	72	100	----	mcd	I _F = 20mA
		G	112	180	----		
		B	28.5	50	----		
2θ _{1/2}	Viewing Angle		----	120	----	deg	I _F = 20mA
λ _P	Peak Wavelength	K	----	611	----	nm	I _F = 20mA
		G	----	518	----		
		B	----	468	----		
λ _d	Dominant Wavelength	K	----	605	----	nm	I _F = 20mA
		G	----	525	----		
		B	----	470	----		
Δλ	Spectral Bandwidth	K	----	17	----	nm	I _F = 20mA
		G	----	35	----		
		B	----	35	----		
V _F	Forward Voltage	K	----	2.0	2.4	V	I _F = 20mA
		G	----	3.3	3.9		
		B	----	3.3	3.9		
I _R	Reverse Current	K	----	----	10	μA	V _R = 5V
		G	----	----	50		
		B	----	----	50		

Typical Electro-Optical Characteristics Curves – K (Yellow-Orange)

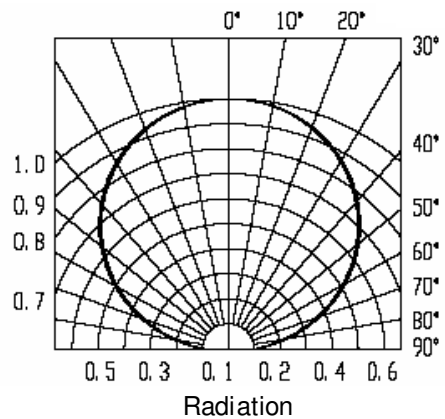
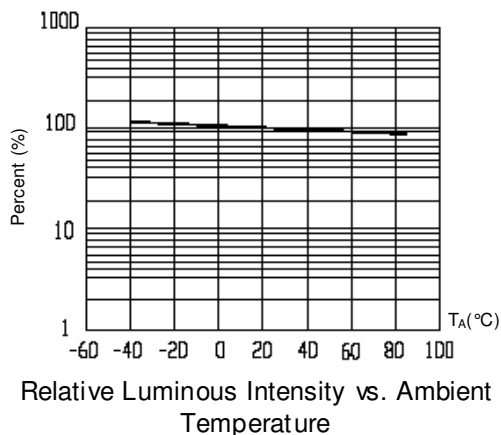
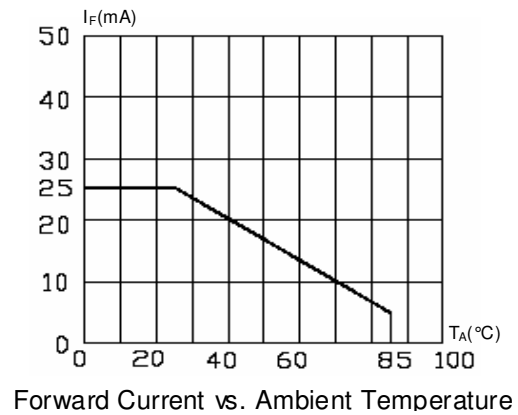
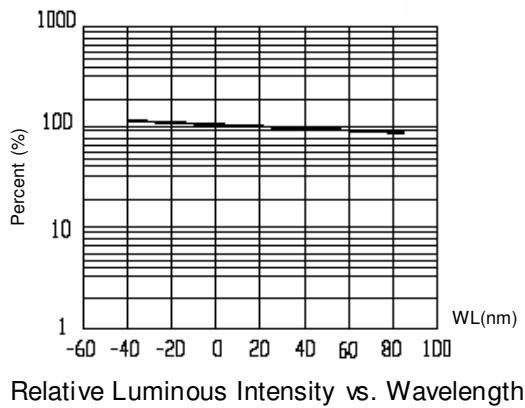
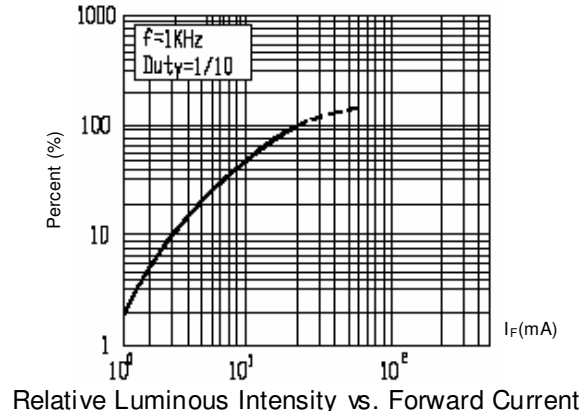
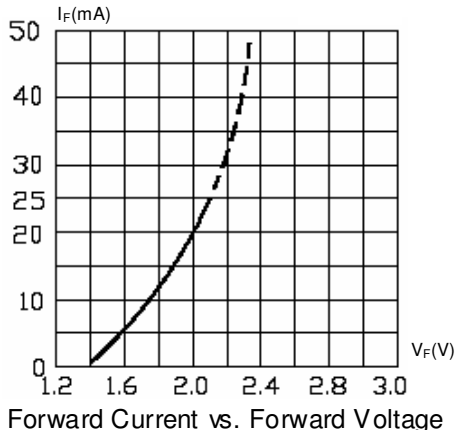

Typical Electro-Optical Characteristics Curves – G (Green)

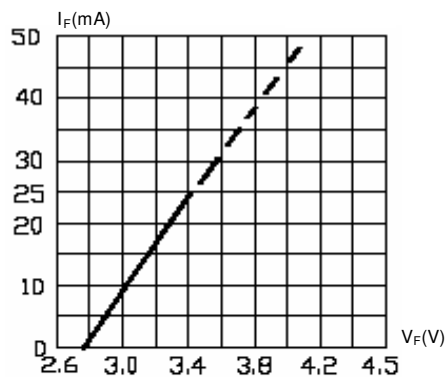

Forward Current vs. Forward Voltage

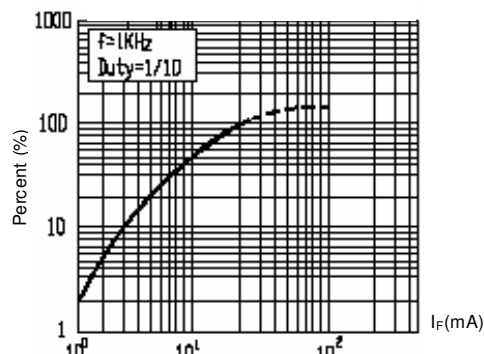

Relative Luminous Intensity vs. Forward Current

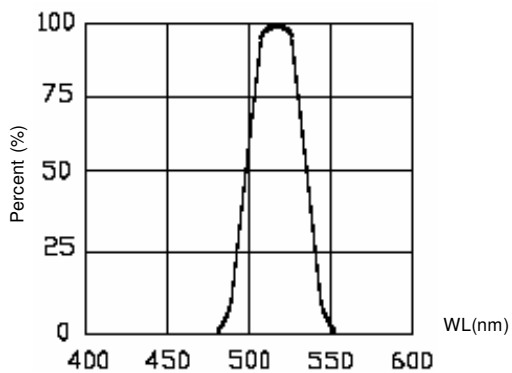

Relative Luminous Intensity vs. Wavelength

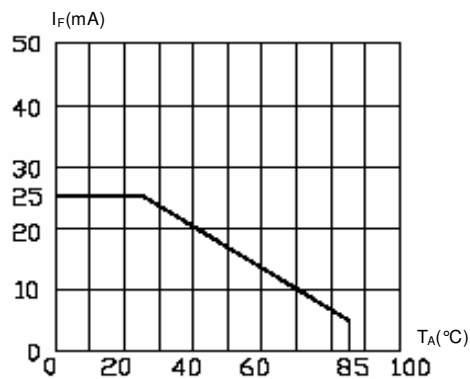

Forward Current vs. Ambient Temperature

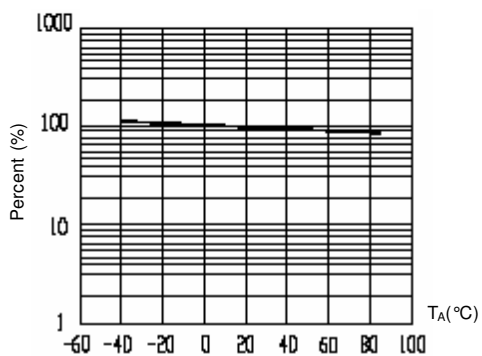

Relative Luminous Intensity vs. Ambient Temperature

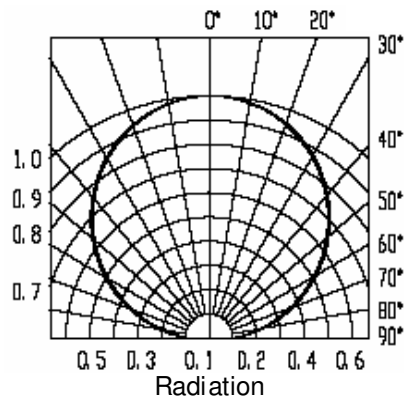

Typical Electro-Optical Characteristics Curves – B (Blue)

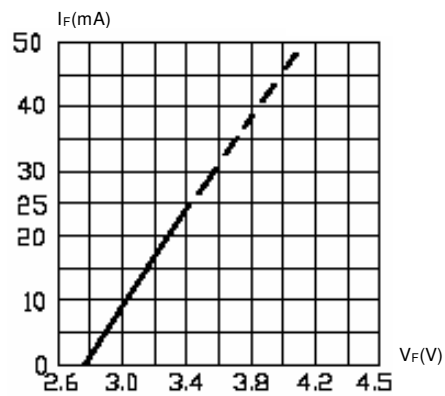

Forward Current vs. Forward Voltage

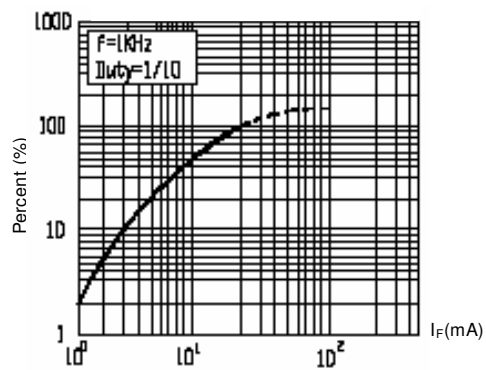

Relative Luminous Intensity vs. Forward Current

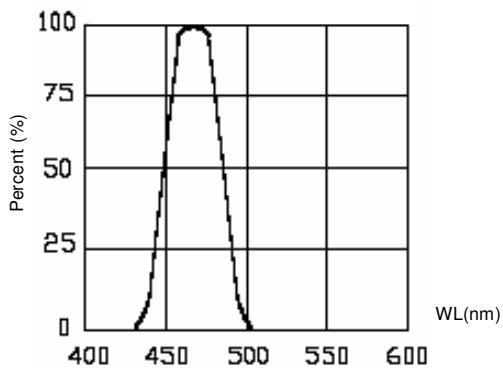

Relative Luminous Intensity vs. Wavelength

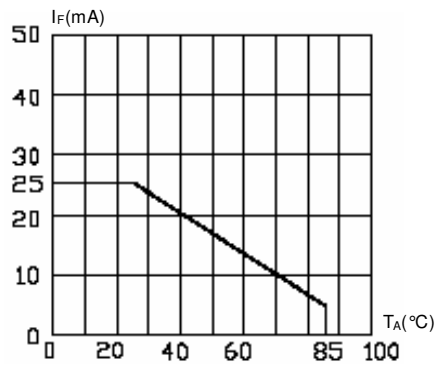

Forward Current vs. Ambient Temperature

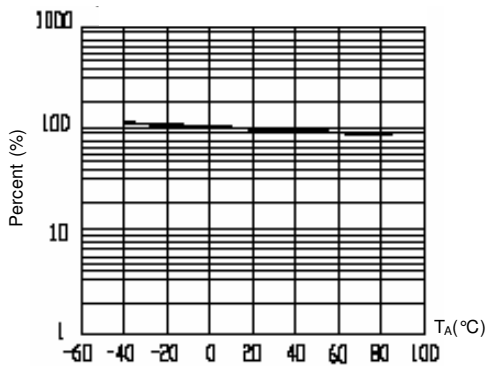

Relative Luminous Intensity vs. Ambient Temperature

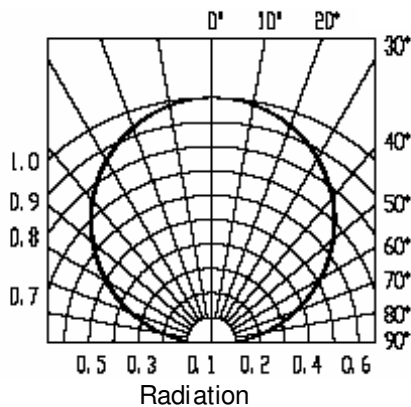

Full Color .35mm Height Chip LED OVSTKGBBCR9

Reel Dimensions (7 Inch)

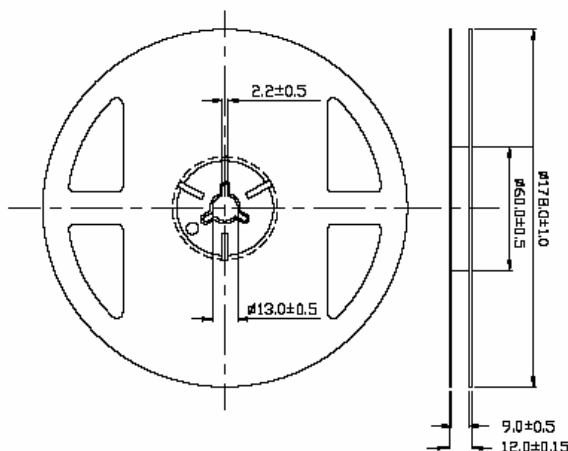

Carrier Tape Dimensions: Loaded Quantity 2000 PCS per Reel

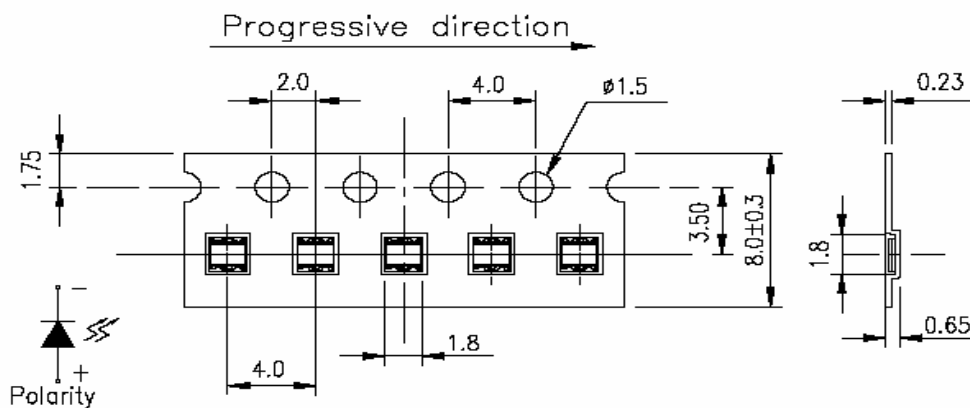

Moisture Resistant Packaging

