

THIS DRAWING IS UNPUBLISHED. RELEASED FOR PUBLICATION  
 © COPYRIGHT 2011 BY TYCO ELECTRONICS CORPORATION. ALL RIGHTS RESERVED.

LOC DW	DIST	REVISIONS			DATE	DWN	APVD
		P	LTR	DESCRIPTION			
		A2		ECR-12-012115	26OCT'12	EL	WK

- NOTE:
- MATERIAL:
    - HOUSING: PA46, WITH 30% GF, UL94 V-0, BLACK COLOR.
    - CONTACTS: PHOSPHOR BRONZE.
    - SHELL: BRASS.
  - FINISH:
    - CONTACTS: (SEE TABLE) GOLD PLATED ON CONTACT AREA, 1.27um [50u"] MIN. NICKEL UNDERPLATED OVERALL.
    - SHELL: 0.508um [20u"] MIN. NICKEL PLATED.  
PCB GROUND: TIN PLATED.
  - REFLOW SOLDER CAPABLE TO 260°C PER TEC-109-201, CONDITION B.

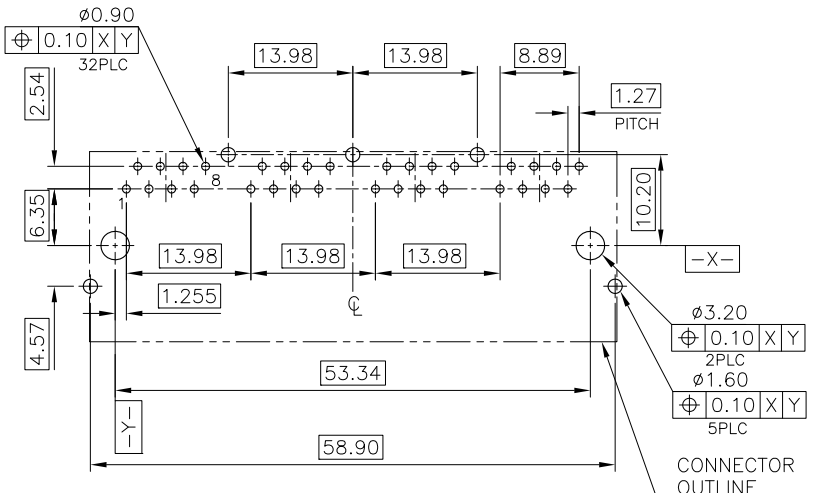
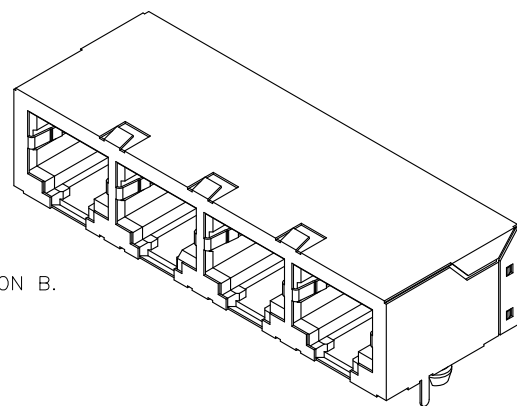

RECOMMENDED PCB LAYOUT  
 RECOMMENDED PCB THICKNESS: 1.6mm.  
 TOLERANCE: ±0.05 (TOP VIEW)

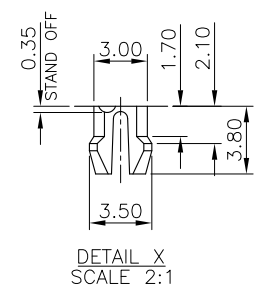
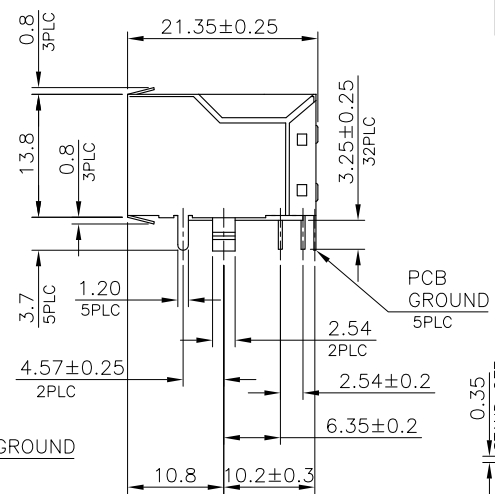
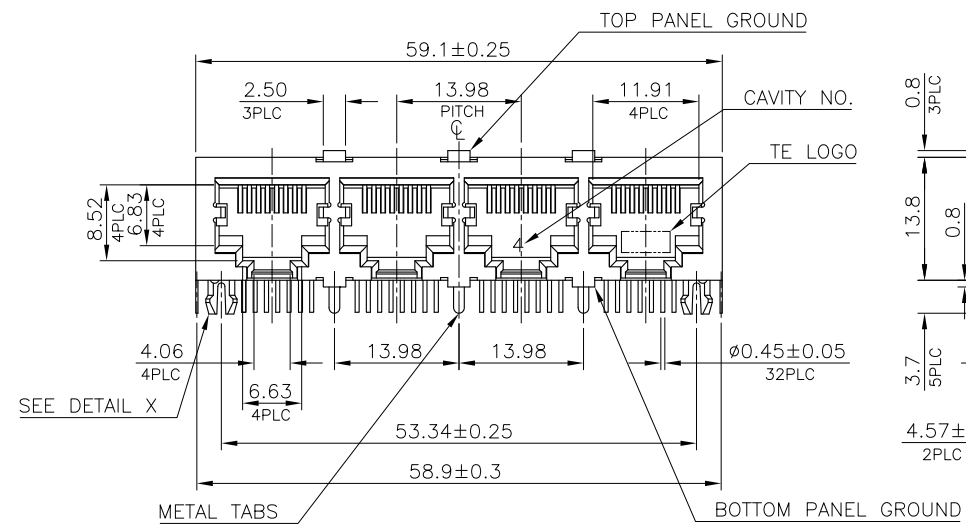

OBSOLETE	TRAY	1.27um[50u"]	1-1734714-4
OBSOLETE		0.76um[30u"]	1-1734714-3
OBSOLETE		0.38um[15u"]	1-1734714-2
OBSOLETE	TUBE	0.15um[6u"]	1-1734714-1
OBSOLETE		1.27um[50u"]	1734714-4
OBSOLETE		0.76um[30u"]	1734714-3
OBSOLETE		0.38um[15u"]	1734714-2
OBSOLETE		0.15um[6u"]	1734714-1
	PACKAGE	MIN. GOLD THICKNESS	PART NUMBER

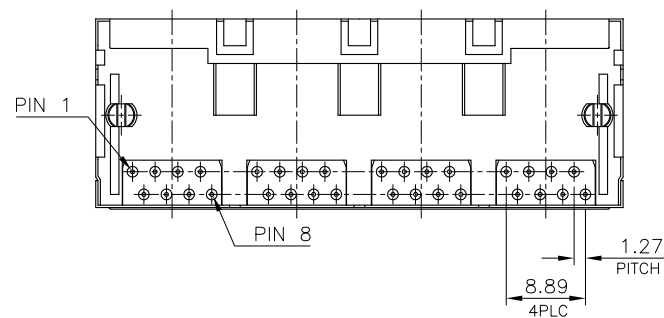

THIS DRAWING IS A CONTROLLED DOCUMENT.		DWN S. CHIEN	20FEB2008	<b>STE</b> TE Connectivity
DIMENSIONS: mm		CHK S. HOU	20FEB2008	
TOLERANCES UNLESS OTHERWISE SPECIFIED:		APVD W. KODAMA	20FEB2008	NAME MODULAR JACK, RJ45, MULTI-PORT, SHIELDED, THRU-HOLE, PANEL GROUND
0 PLC ± -		PRODUCT SPEC 108-57136		
1 PLC ± 0.3		APPLICATION SPEC		SIZE A3
2 PLC ± 0.2				
3 PLC ± 0.15		WEIGHT 22.41 GRAMS		CAGE CODE 00779
4 PLC ± -				
ANGLES ± - ± 3'				DRAWING NO C-1734714
MATERIAL SEE NOTE				
FINISH SEE NOTE				RESTRICTED TO -
		CUSTOMER DRAWING	SCALE	
			SHEET 1 OF 2	REV A2

THIS DRAWING IS UNPUBLISHED. RELEASED FOR PUBLICATION  
 © COPYRIGHT 2011 BY TYCO ELECTRONICS CORPORATION. ALL RIGHTS RESERVED.

LOC	DIST	REVISIONS					
DW		P	LTR	DESCRIPTION	DATE	DWN	APVD
				SEE SHEET 1.			

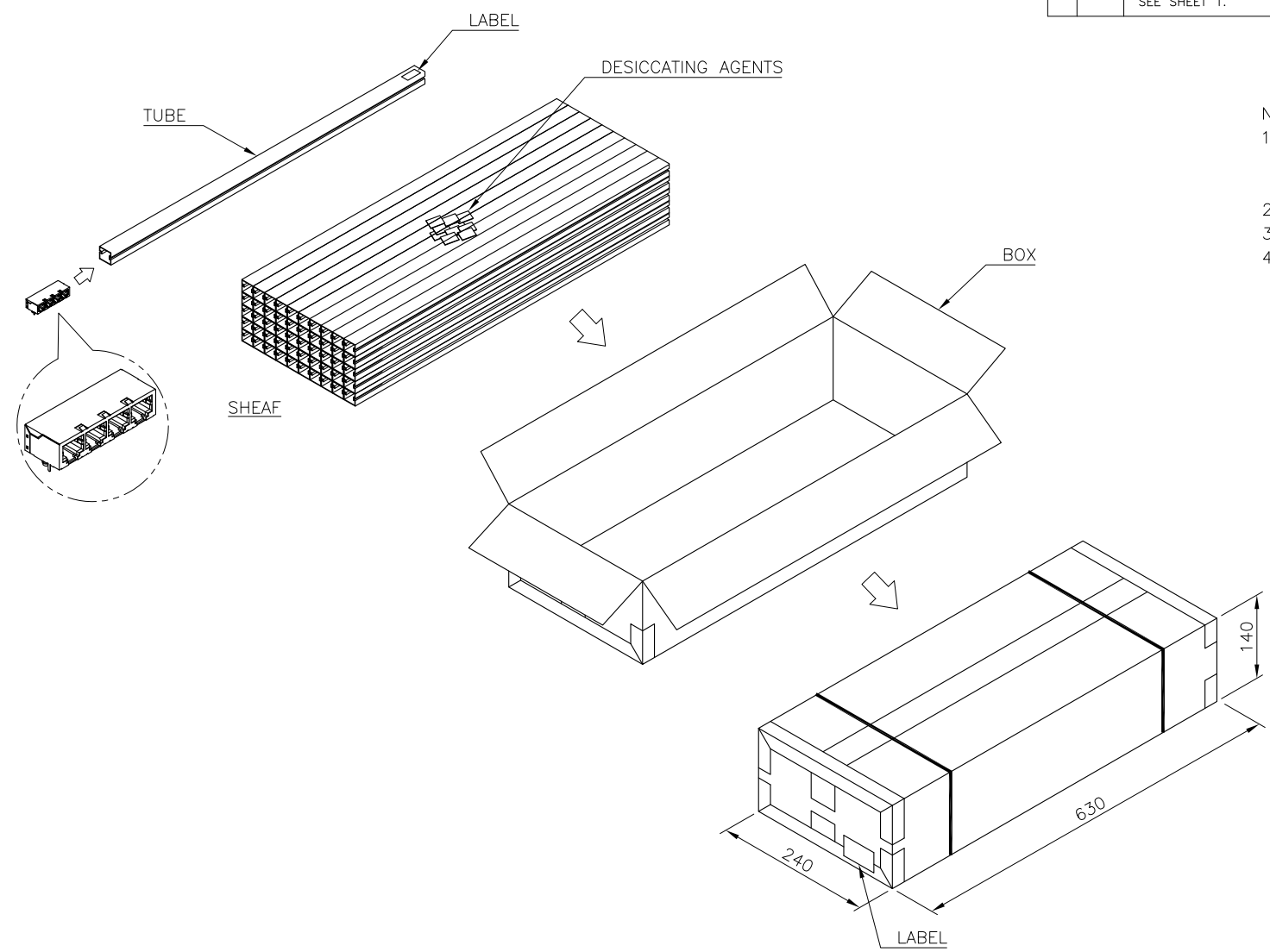

- NOTES:  
 1. MATERIAL:  
     TUBE: PVC.  
     BOX: CORRUGATED FIBER.  
 2. DIMENSION: SEE DRAWING  
 3. QUANTITY: SEE TABLE  
 4. WEIGHT: SEE TABLE

13.40KG	10.08G	9	50	450
GROSS WEIGHT	NET WEIGHT	PCS/TUBE	TUBES/BOX	PCS/BOX

THIS DRAWING IS A CONTROLLED DOCUMENT.		DWN	TE Connectivity		
DIMENSIONS: mm		CHK	NAME		
TOLERANCES UNLESS OTHERWISE SPECIFIED:		APVD	MODULAR JACK, RJ45, MULTI-PORT, SHIELDED, THRU-HOLE, PANEL GROUND		
0 PLC ± . 1 PLC ± 0.3 2 PLC ± 0.2 3 PLC ± 0.15 4 PLC ± . ANGLES ± 3'		PRODUCT SPEC	SIZE	CAGE CODE	DRAWING NO
MATERIAL		APPLICATION SPEC	A3	00779	C=1734714
FINISH		WEIGHT	RESTRICTED TO		
		CUSTOMER DRAWING	SCALE	SHEET	REV
				2 of 2	A2