

THIS DRAWING IS UNPUBLISHED. RELEASED FOR PUBLICATION
 © COPYRIGHT - BY TYCO ELECTRONICS CORPORATION. ALL RIGHTS RESERVED.

LOC	DIST	REVISIONS					
GP	00	P	LTR	DESCRIPTION	DATE	DWN	APVD
			B	REV PER ECO-06-019010	17AUG06	TK	DO

7 MODULE INFORMATION

CONNECTOR	TYCO PART NUMBER	ELCON PART NUMBER	CATALOG MODULE #	QTY	SIZE NO.	CONTACT QTY	MATING PIN	MAX. CURRENT (PER CONTACT)	CONTACT SPACING	VOLTAGE RATING*
SOCKET	6766005-1	278-1169-10200A	FP0200	4	8	4	1.25 X 7.00 [.049 X .276]	35 AMPERES	7.50 [295]	250 VOLTS
			FP0515	2	ACTIVATED STRAIGHT GUIDE PIN					
			FP0744	1	8	4	1.25 X 7.00 [.049 X .276]	35 AMPERES	7.50 [295]	250 VOLTS
					22	24	.64 [025] SQ.	3 AMPERES	2.50 [098]	125 VOLTS

*IAW IEC-950

NOTES: UNLESS OTHERWISE SPECIFIED.

- PART NUMBER CHANGES AND OR DESIGN CHANGES AFFECTING ITEM INTERCHANGEABILITY REQUIRE PRIOR ELCON APPROVAL AND AUTHORIZATION BY REVISION TO THIS DRAWING.
- MATERIALS:
 INSULATORS: THERMOPLASTIC, GLASS REINFORCED, COLOR BLACK, UL94V-0 FLAMMABILITY RATED.
 SOLDER SIGNAL PIN: BRASS ALLOY.
 POWER CONTACTS: PHOSPHOR-BRONZE ALLOY, COPPER ALLOY.
 CROWN BANDS: BERYLLIUM-COPPER ALLOY.
 GUIDE PIN: BRASS-COPPER ALLOY.
- FINISHES:
 CONTACTS: GOLD PLATED PER TYCO SPEC 112-162-5, .00076 [.000030] MIN THICK OVER NICKEL PER TYCO SPEC 112-25-2, .00130 [.000050] MIN THICK.
 SOLDER TAILS: TIN PLATED PER LEAD FREE TYCO SPEC 112-65-1, MATT FINISH .0030 TO .0043 [.000120 TO .000170] THICKNESS.
- RECOMMENDED PRESSING TOOL: FIX00310 FOR PN 278-1169-10200A. CONTACT ELCON FOR TOOLING QUOTE OR TO ORDER.
- ACTIVATED GUIDE PIN ACCEPTS M3 SCREW (USER SUPPLIED).
- ITEMS PROVIDED TO THIS SPECIFICATION TO BE PERMANENTLY IDENTIFIED PER THE FOLLOWING IDENTIFIER:

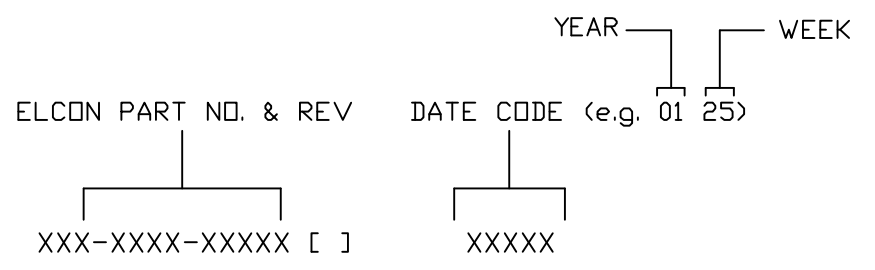

THIS DRAWING IS A CONTROLLED DOCUMENT.		DWN	M.C.CANT	15APR05	Tyco Electronics Corporation Harrisburg, PA 17105-3608		
DIMENSIONS: mm [INCHES]		CHK	-	-	NAME		
		TOLERANCES UNLESS OTHERWISE SPECIFIED:		APVD	D.CHAU	03MAY05	PRODUCT SPEC
MATERIAL		FINISH		APPLICATION SPEC		SOCKET CONNECTOR, FLATPAQ STRAIGHT, COMPLIANT TAILS PN: 278-1169-10200A	
-		-		SIZE	A3	CAGE CODE	00779
				DRAWING NO	C-6766005		RESTRICTED TO
				WEIGHT	-		-
CUSTOMER DRAWING				SCALE	1:1	SHEET	1 OF 3
				REV	B		

THIS DRAWING IS UNPUBLISHED. RELEASED FOR PUBLICATION
 © COPYRIGHT - BY TYCO ELECTRONICS CORPORATION. ALL RIGHTS RESERVED.

LOC	DIST	REVISIONS					
GP	00	P	LTR	DESCRIPTION	DATE	DWN	APVD
				SEE SHEET 1			

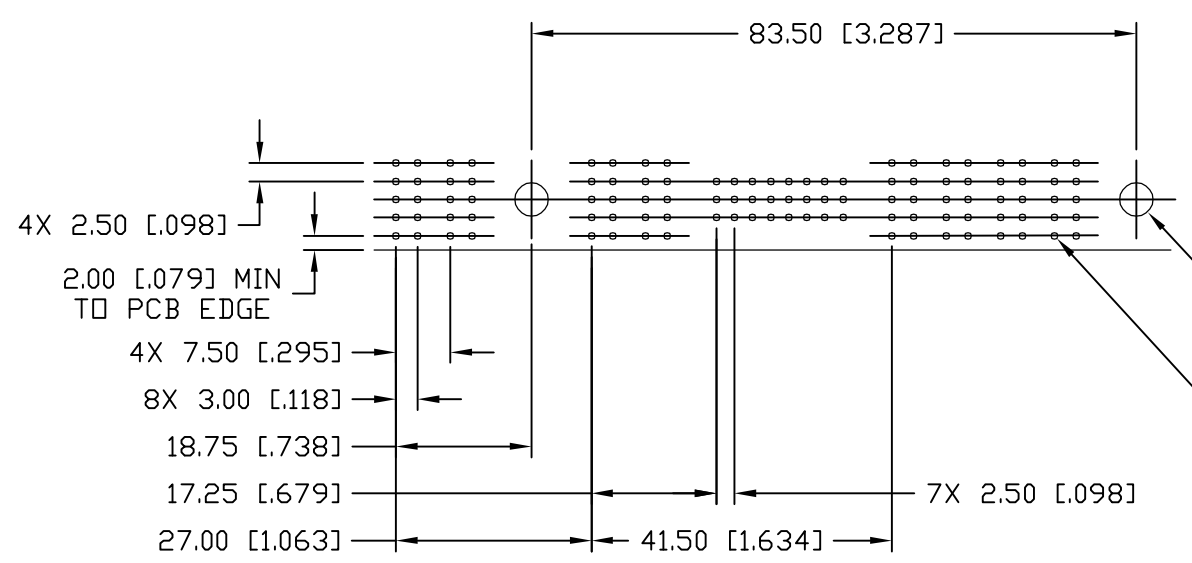
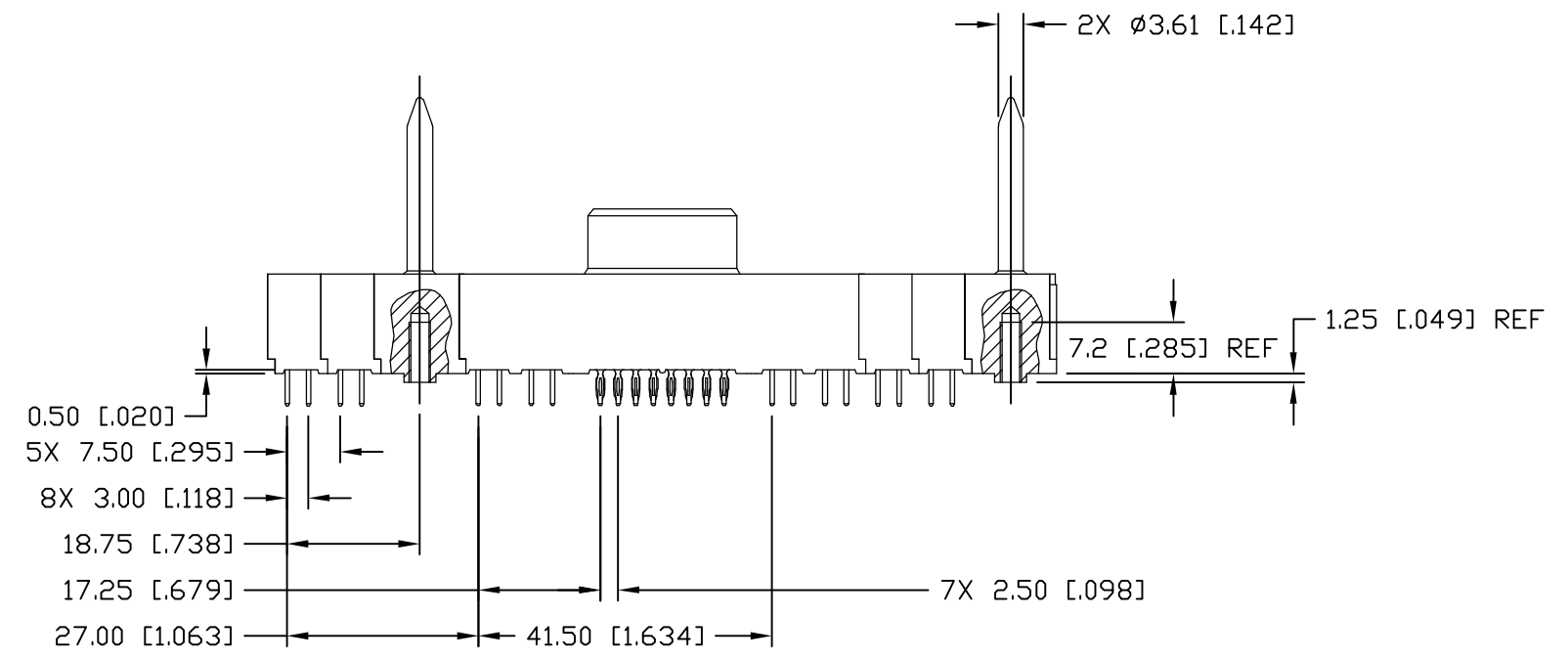
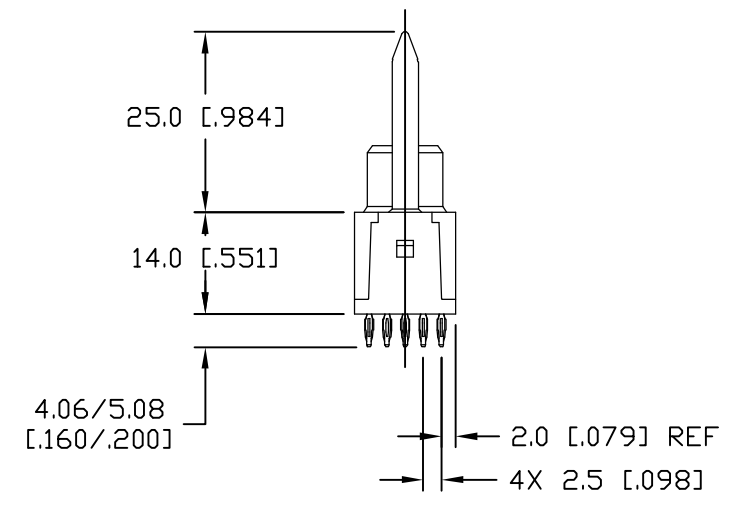
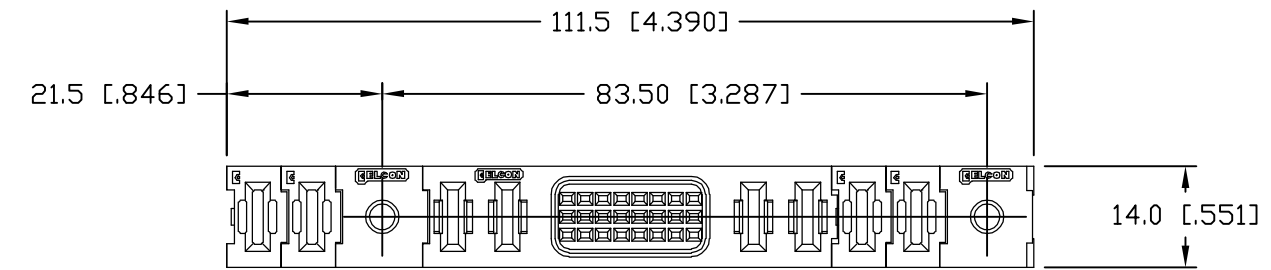

PRINTED CIRCUIT LAYOUT

2X Ø4.75 [Ø.187] PLATED THRU
 104X Ø1.02 [Ø.040] THRU (SEE SHT 3)

THIS DRAWING IS A CONTROLLED DOCUMENT.		DWN	M.C.CANT	15APR05	Tyco Electronics Corporation Harrisburg, PA 17105-3608			
DIMENSIONS: mm [INCHES]		CHK	-	-				NAME
TOLERANCES UNLESS OTHERWISE SPECIFIED:		APVD	D.CHAU	03MAY05	SOCKET CONNECTOR, FLATPAQ STRAIGHT, COMPLIANT TAILS PN: 278-1169-10200A			
0 PLC ± -		PRODUCT SPEC	-	-	SIZE	CAGE CODE	DRAWING NO	RESTRICTED TO
1 PLC ± .5 [.020]		APPLICATION SPEC	-	-	A3	00779	C-6766005	-
2 PLC ± .25 [.010]		WEIGHT	-	-	CUSTOMER DRAWING			SCALE
3 PLC ± -		MATERIAL		-	1:1			SHEET
4 PLC ± -		FINISH		-	2 OF 3			REV
ANGLES ± -		-		-	B			

THIS DRAWING IS UNPUBLISHED. RELEASED FOR PUBLICATION
 © COPYRIGHT BY TYCO ELECTRONICS CORPORATION. ALL RIGHTS RESERVED.

LOC	DIST	REVISIONS			
P	LTR	DESCRIPTION	DATE	DWN	APVD
GP	00	SEE SHEET 1	-	-	-

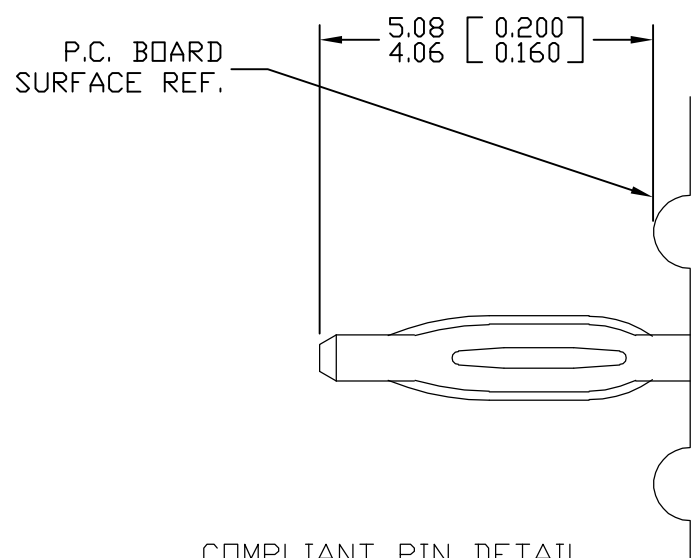

COMPLIANT PIN DETAIL
 SCALE: 10 : 1
 INSERTION/EXTRACTION FORCES
 MAXIMUM PUSH IN: 133.3N PER PIN
 [30 LBS]
 MINIMUM PUSH OUT: 44.4N PER PIN
 [10 LBS]

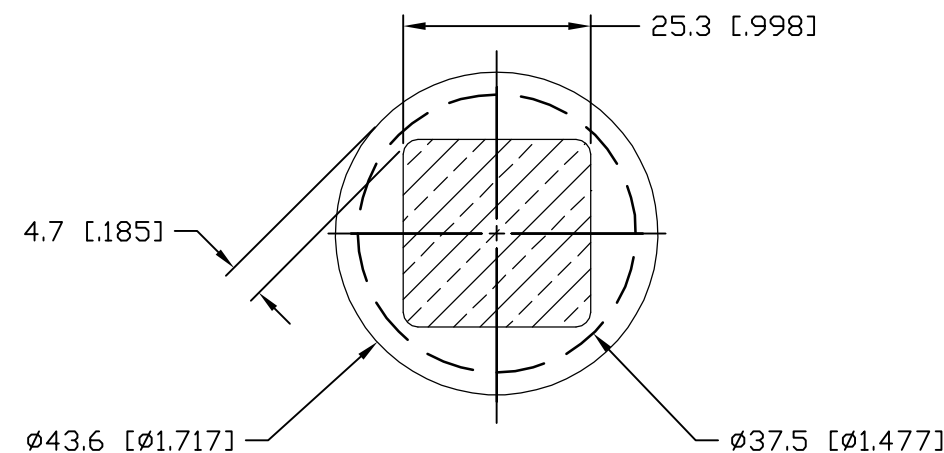

SOLDER TERMINATION AREA
 SCALE: 40 : 1
 RECOMMENDED PRINTED CIRCUIT HOLE
 SOLDER OR COMPLIANT PRESS FIT
 FINISHED HOLE: $\phi 1.02$ [0.40] ± 0.08 [0.03]
 DRILLED HOLE: $\phi 1.15$ [0.453] ± 0.13 [0.005]
 COPPER PLATE: .025 [0.010] MINIMUM (PER SURFACE)
 TIN PLATE: .008 [0.003] MINIMUM (PER SURFACE)

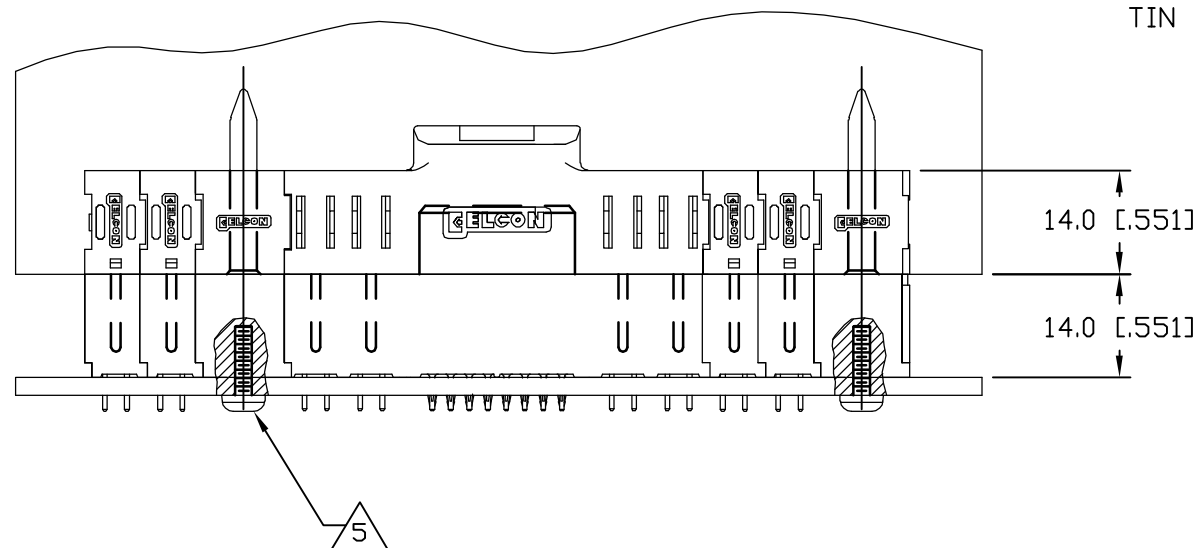
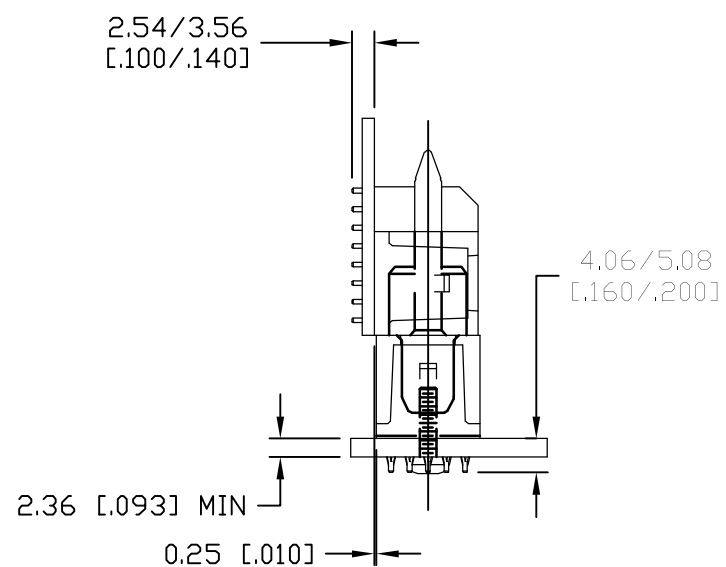

MATED CONDITION

THIS DRAWING IS A CONTROLLED DOCUMENT.		DWN M.C.CANT	15APR05	tyco Tyco Electronics Corporation	
DIMENSIONS: mm [INCHES]		CHK -	-	Electronics Harrisburg, PA 17105-3608	
TOLERANCES UNLESS OTHERWISE SPECIFIED:		APVD D.CHAU	03MAY05	NAME	
0 PLC $\pm -$		PRODUCT SPEC		SOCKET CONNECTOR, FLATPAQ	
1 PLC $\pm .5$ [0.020]		APPLICATION SPEC		STRAIGHT, COMPLIANT TAILS	
2 PLC $\pm .25$ [0.010]		-		PN: 278-1169-10200A	
3 PLC $\pm -$		SIZE	CAGE CODE	DRAWING NO	RESTRICTED TO
4 PLC $\pm -$		-		A3	-
ANGLES $\pm -$		-		00779	C-6766005
FINISH		WEIGHT		-	
-		-		-	
CUSTOMER DRAWING				SCALE	1:1
				SHEET	3 OF 3
				REV	B