

CATALOG NUMBER	MATERIAL NUMBER	CONDUIT SIZE	N.P.T. FITTING SIZE	LENGTH "M"	DIAMETER "A" REF.	LENGTH "B" REF.	LENGTH "C" REF.	PRODUCT SELECTION NUMBER	UL LISTED	CSA APRVD
37100	-----	3/8"	3/8"	9.00±1.00 / 228.6±25.4	1.2 / 30	1.16 / 29.5	.59 / 15.0	STNM038W	YES	NO
37101	1300960069	1/2"	1/2"	10.00±1.00 / 254.0±25.4	1.4 / 36	1.31 / 33.3	.59 / 15.0	STNM050W		
37102	1300960071	3/4"	3/4"	11.50±1.00 / 292.1±25.4	1.6 / 41	1.63 / 41.4	.59 / 15.0	STNM075W		
37103	1300960073	1"	1"	12.00±1.00 / 304.8±25.4	1.9 / 48	1.94 / 49.3	.72 / 18.3	STNM100W		
37104	1300960075	1-1/4"	1-1/4"	17.00±1.50 / 431.8±38.1	2.4 / 61	2.41 / 61.2	.75 / 19.1	STNM125W		
37105	1300960077	1-1/2"	1-1/2"	21.50±2.00 / 546.1±50.8	2.9 / 74	2.78 / 70.6	.75 / 19.1	STNM150W		
37106	1300960079	2"	2"	24.00±2.00 / 609.6±50.8	3.5 / 89	3.38 / 85.9	.75 / 19.1	STNM200W		

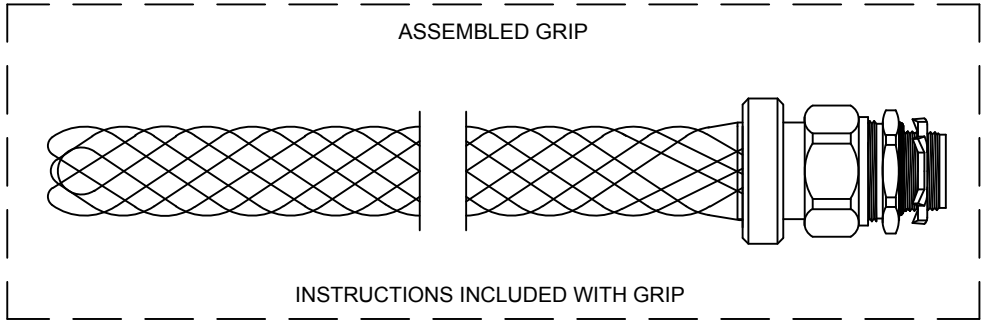
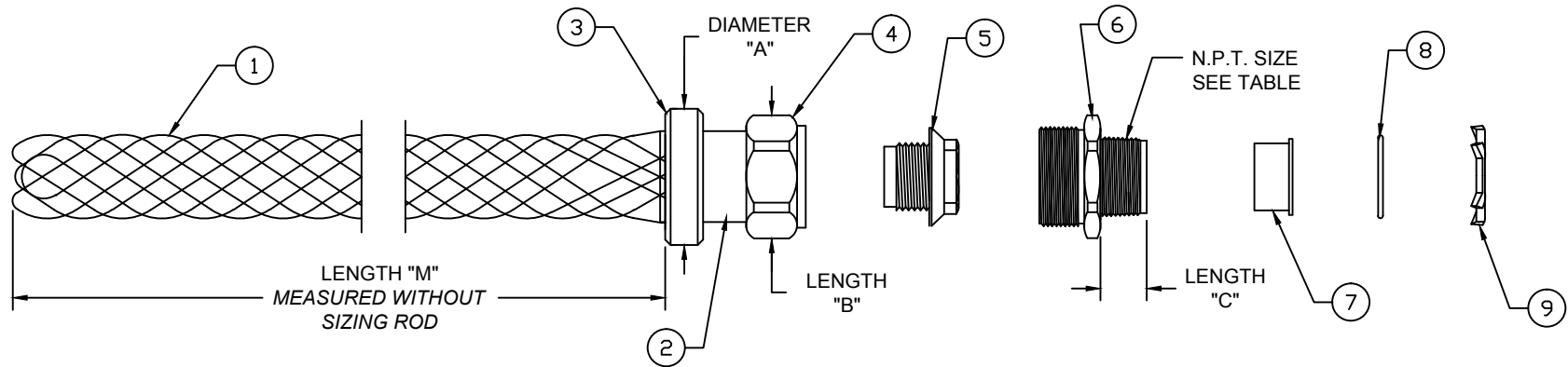

ITEM	DESCRIPTION	MATERIAL
1	WIRE MESH	STAINLESS STEEL
2	INNER RING	ZINC PLATED STEEL
3	OUTER RING	ALUMINUM
4	COMPRESSION NUT	ZINC PLATED STEEL OR ZINC PLATED CAST IRON
5	FERRULE	NYLON
6	THREADED BODY	ZINC PLATED STEEL OR ZINC PLATED CAST IRON
7	THROAT INSULATION	PLASTIC
8	O'RING	NEOPRENE
9	LOCK NUT	ZINC PLATED STEEL

RELEASE SALES DRAWING	EC NO: IPC2015-0574
DRWN: HRUIZ01	2014/09/24
CHKD: HKNEELAN	2014/09/24
APPR: JFMURPHY	2015/04/27
REV	A

QUALITY SYMBOLS	$\nabla = 0$ $\nabla C = 0$
-----------------	--------------------------------

GENERAL TOLERANCES (UNLESS SPECIFIED)	
	mm INCH
4 PLACES	±--- ±---
3 PLACES	±--- ±.005
2 PLACES	±.13 ±.010
1 PLACE	±.25 ±.020
ANGULAR ±1/2°	
DRAFT WHERE APPLICABLE MUST REMAIN WITHIN DIMENSIONS	

DIMENSION STYLE INCH/MM	
DRAWN BY	DATE
HRUIZ01	2014/09/24
CHECKED BY	DATE
HKNEELAN	2014/09/24
APPROVED BY	DATE
JFMURPHY	2015/04/27
MATERIAL NO.	
SEE TABLE	
SIZE	A

SCALE NTS	DESIGN UNITS INCH	THIRD ANGLE PROJECTION
TITLE		
STRAIN RELIEF L.T. NON-METALLIC TYPE A CONDUIT - STRAIGHT MALE		
MOLEX INCORPORATED		
DOCUMENT NO.		SHEET NO.
SD-130096-104		1 OF 1
THIS DRAWING CONTAINS INFORMATION THAT IS PROPRIETARY TO MOLEX INCORPORATED AND SHOULD NOT BE USED WITHOUT WRITTEN PERMISSION		