

Solder Cup Plug: 11-9159-WTB

General Description



The 9159 series of Board-to-Board interconnect system allows two PCB's to be mated end-to-end creating strips of LED lighting. Designed specifically for the unique Solid State Lighting (SSL) market requiring coplanar (horizontal-to-horizontal) PCB mating with a 5 Amp current rating in the smallest package available. The cabled plug was developed to bring power and signals onto the PCB's while keeping the same board level interface. This allows the designer to build a single PCB with a receptacle on one end and a plug on the other end to minimize cost and inventory. Regardless of where the PCB is used in the system, the cabled plug connector will then create the connection to the outside world. The optional latch can be inserted into the plug housing to assure positive attachment to the PCB in harsh environments without having to change the PCB connector.

APPLICATIONS

- Provided Wire-to-Board capabilities to standard 9159 2-Piece connector system
- Application Notes: refer to 201-01-123
- Product Specification: refer to 201-01-119

FEATURES AND BENEFITS

- Mates with standard horizontal socket: no need to change any connectors
- 5 Amp current rating: exceeds general market needs
- Wires are soldered into connector with tie wrap strain relief: simplicity
- Optional latch: provides positive attachment to PCB connector

ELECTRICAL

- Current Rating: 5 Amps / Contact
- Voltage Rating: 125 VAC (RMS) or DC Equivalent

ENVIRONMENTAL

- Operating Temperature: -40°C to +125°C
- Storage Temperature: -40°C to +70°C

MECHANICAL

- Insulator Material: Nylon: VL94V0
- Contact Material: BeCu / Phos Bronze
- Plating: Gold / Tin over Nickel
- Durability: 10 Cycles

HOW TO ORDER

11
Prefix
Wire Plug
Soldered
Terminations

9159
Series

00X
Number of Ways

| Code | No of Ways | Details |
|------|------------|---------|
| 002 | 2 | Page 11 |
| 003 | 3 | Page 12 |
| 004 | 4 | Page 13 |
| 005 | 5 | Page 14 |
| 006 | 6 | Page 15 |

Optional Cover
See page 16 for ordering code
Optional Latch
See page 17 for ordering code

1
2 Part
PCB Strip
Connector

01
Connector
Pitch
01 = 3mm

9
Color/Approva

| Code | Color | Approval |
|------|-------|-------------|
| 9 | White | UL Approved |

16
Plating Option

| Code | Contact |
|------|--|
| 16 | Gold in Contact Area Tin on Solder Tail |

NOTES: Connectors are supplied with cable ties (see page 19).
Covers/Latches are sold separately (see pages 16-17 for ordering codes).

Safety Standards: UL 1977-File #E90723, CSA C22.2 NO. 182.3



Solder Cup Plug: 11-9159-WTB

2 Position

PLUG WIRED 2 WAY 2 PART 9159 LIGHTING CONNECTOR

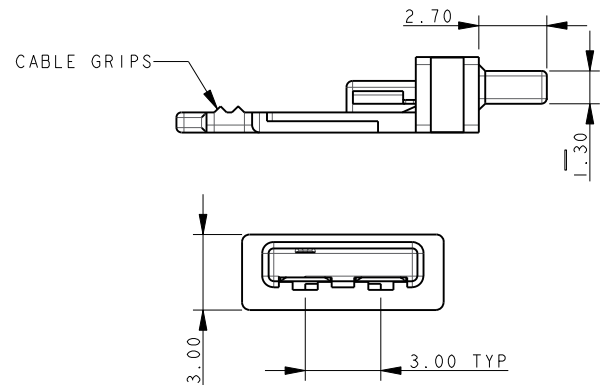
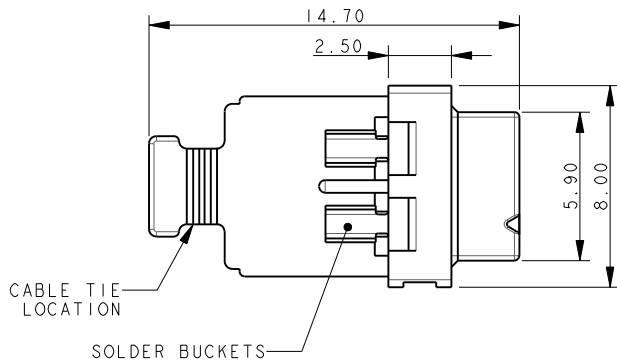

NOTES:

1. FOR MORE INFORMATION REFER TO PRODUCT SPEC 201-01-119.
2. CABLE TIE SUPPLIED FOR WIRE RETENTION, ATTACHED TO EACH REEL. SPARES CAN BE ORDERED, REFER TO PAGE 19.
3. DIMENSIONS ARE REFERENCE DIMENSIONS UNLESS TOLERANCED.
4. INSULATOR MATERIAL: NYLON 46. COLOR REFER TO PAGE 10.
5. CONTACT MATERIAL: COPPER ALLOY, SELECTIVE GOLD OVER NICKEL TIN PLATED ON TAILS.
6. PACKING IN TAPE AND REEL, QUANTITY PER REEL 700.
7. FOR ACCESSORY COVERS AND LATCHES REFER TO PAGES 16 AND 17.

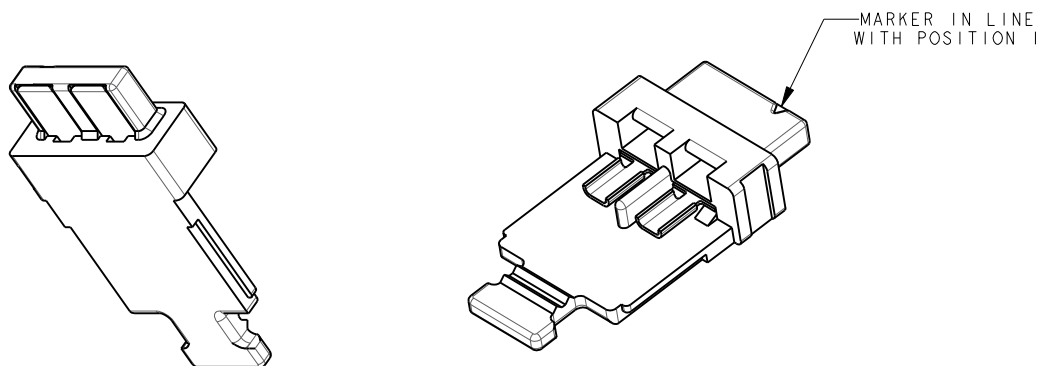

PACKING DETAILS CABLE TIES SUPPLIED WITH EACH REEL

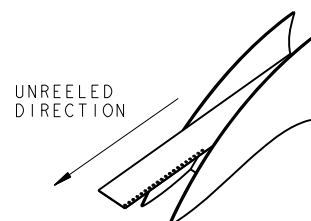
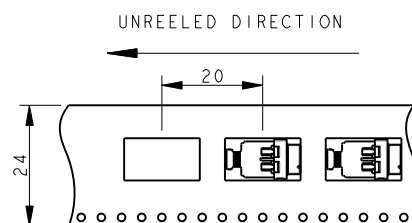

Solder Cup Plug: 11-9159-WTB

3 Position



PLUG WIRED 3 WAY 2 PART 9159 LIGHTING CONNECTOR

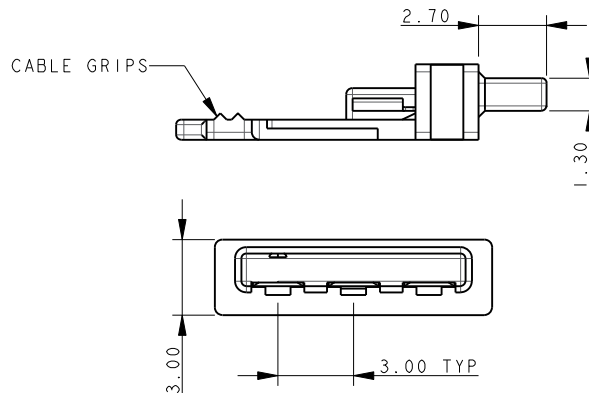
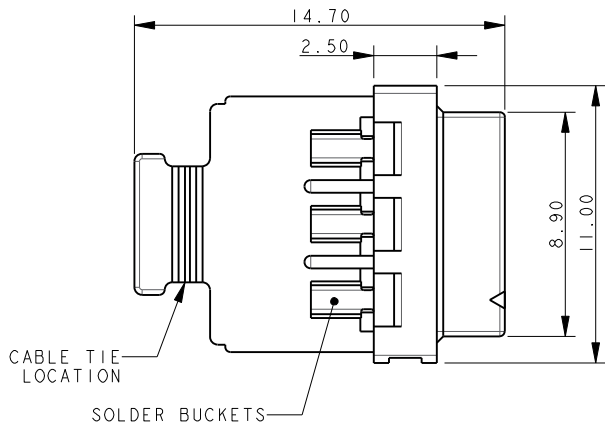

NOTES:

1. FOR MORE INFORMATION REFER TO PRODUCT SPEC 201-01-119.
2. CABLE TIE SUPPLIED FOR WIRE RETENTION, ATTACHED TO EACH REEL. SPARES CAN BE ORDERED, REFER TO PAGE 19.
3. DIMENSIONS ARE REFERENCE DIMENSIONS UNLESS TOLERANCED.
4. INSULATOR MATERIAL: NYLON 46. COLOR REFER TO PAGE 10.
5. CONTACT MATERIAL: COPPER ALLOY, SELECTIVE GOLD OVER NICKEL TIN PLATED ON TAILS.
6. PACKING IN TAPE AND REEL, QUANTITY PER REEL 700.
7. FOR ACCESSORY COVERS AND LATCHES REFER TO PAGES 16 AND 17.

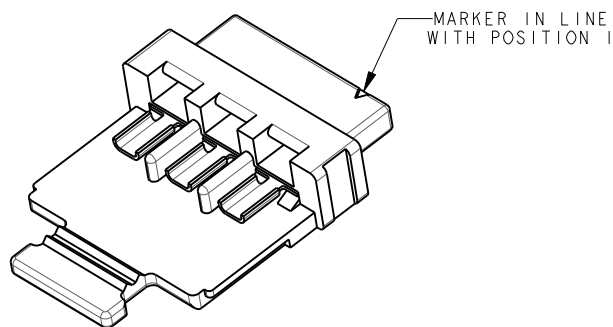
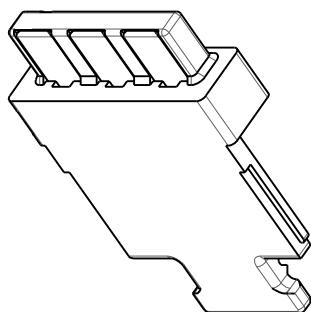

PACKING DETAILS CABLE TIES SUPPLIED WITH EACH REEL

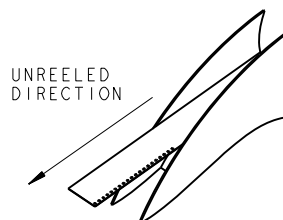
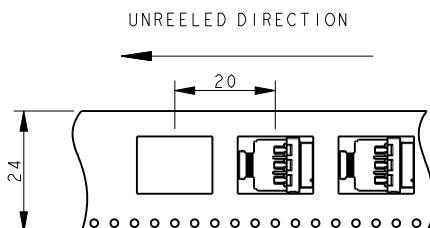

Solder Cup Plug: 11-9159-WTB

4 Position

PLUG WIRED 4 WAY 2 PART 9159 LIGHTING CONNECTOR

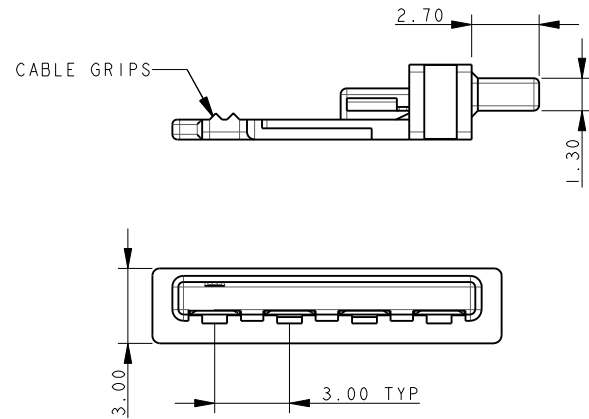
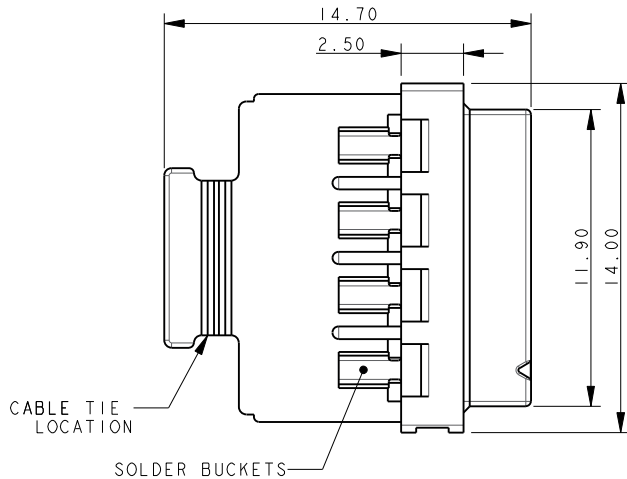

NOTES:

1. FOR MORE INFORMATION REFER TO PRODUCT SPEC 201-01-119.
2. CABLE TIE SUPPLIED FOR WIRE RETENTION, ATTACHED TO EACH REEL. SPARES CAN BE ORDERED, REFER TO PAGE 19.
3. DIMENSIONS ARE REFERENCE DIMENSIONS UNLESS TOLERANCED.
4. INSULATOR MATERIAL: NYLON 46. COLOR REFER TO PAGE 10.
5. CONTACT MATERIAL: COPPER ALLOY, SELECTIVE GOLD OVER NICKEL TIN PLATED ON TAILS.
6. PACKING IN TAPE AND REEL, QUANTITY PER REEL 700.
7. FOR ACCESSORY COVERS AND LATCHES REFER TO PAGES 16 AND 17.

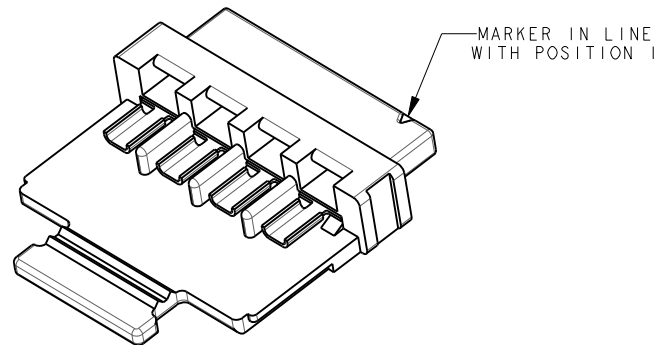
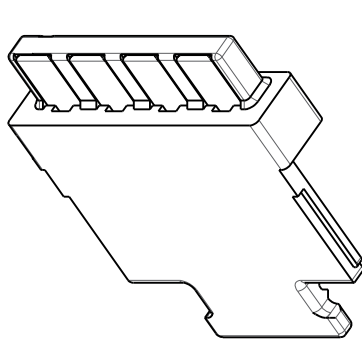

PACKING DETAILS CABLE TIES SUPPLIED WITH EACH REEL

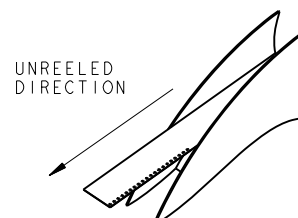
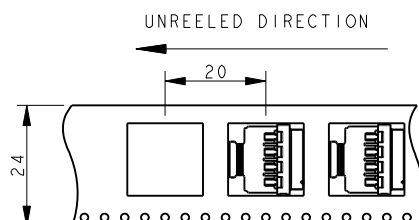

Solder Cup Plug: 11-9159-WTB

5 Position



PLUG WIRED 5 WAY 2 PART 9159 LIGHTING CONNECTOR

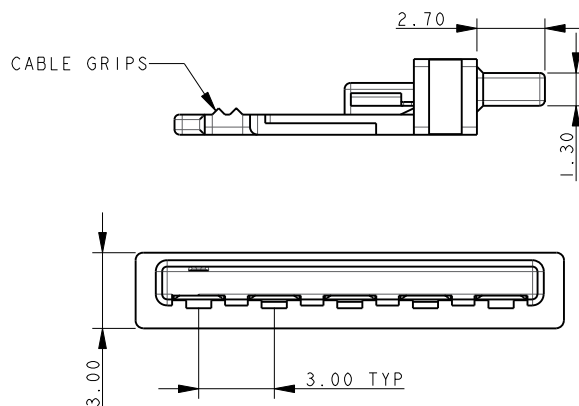
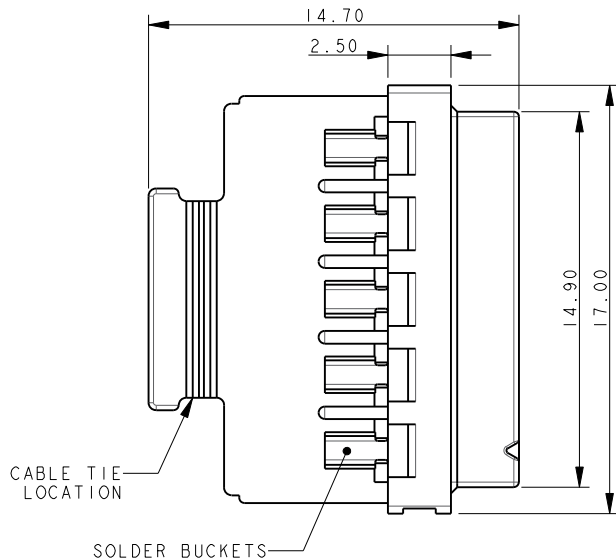

NOTES:

1. FOR MORE INFORMATION REFER TO PRODUCT SPEC 201-01-119.
2. CABLE TIE SUPPLIED FOR WIRE RETENTION, ATTACHED TO EACH REEL. SPARES CAN BE ORDERED, REFER TO PAGE 19.
3. DIMENSIONS ARE REFERENCE DIMENSIONS UNLESS TOLERANCED.
4. INSULATOR MATERIAL: NYLON 46. COLOR REFER TO PAGE 10.
5. CONTACT MATERIAL: COPPER ALLOY, SELECTIVE GOLD OVER NICKEL TIN PLATED ON TAILS.
6. PACKING IN TAPE AND REEL, QUANTITY PER REEL 700.
7. FOR ACCESSORY COVERS AND LATCHES REFER TO PAGES 16 AND 17.

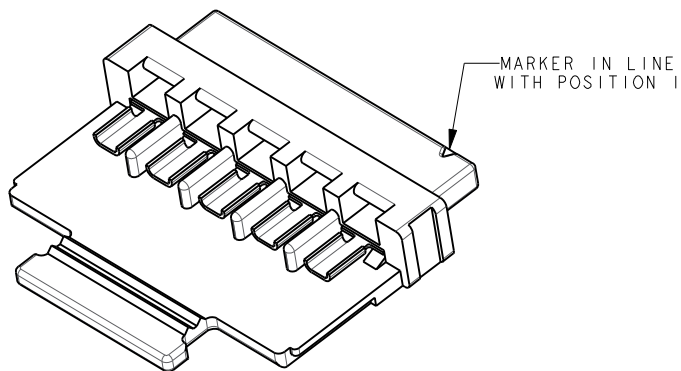
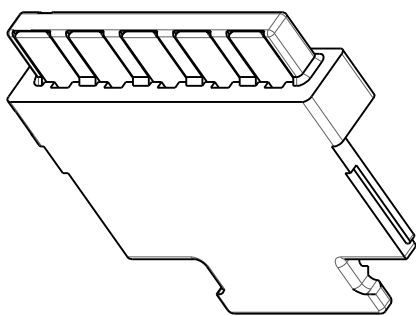

PACKING DETAILS CABLE TIES SUPPLIED WITH EACH REEL

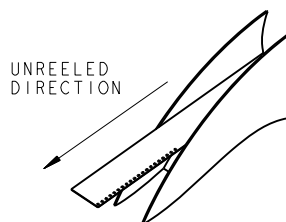
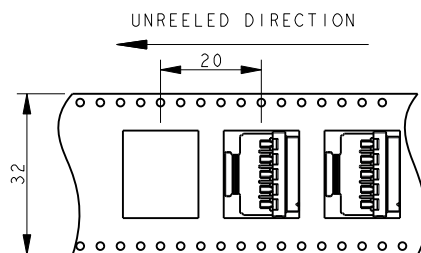

Solder Cup Plug: 11-9159-WTB

6 Position

PLUG WIRED 6 WAY 2 PART 9159 LIGHTING CONNECTOR

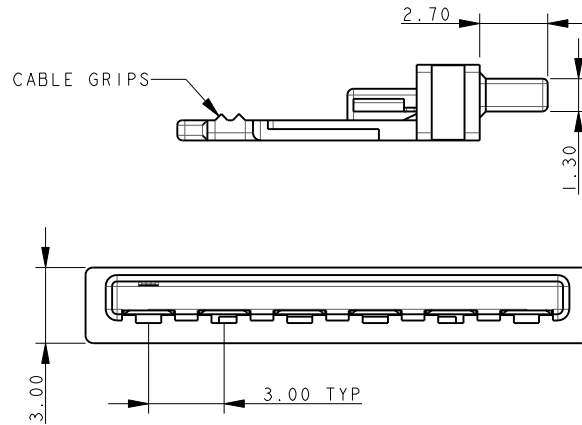
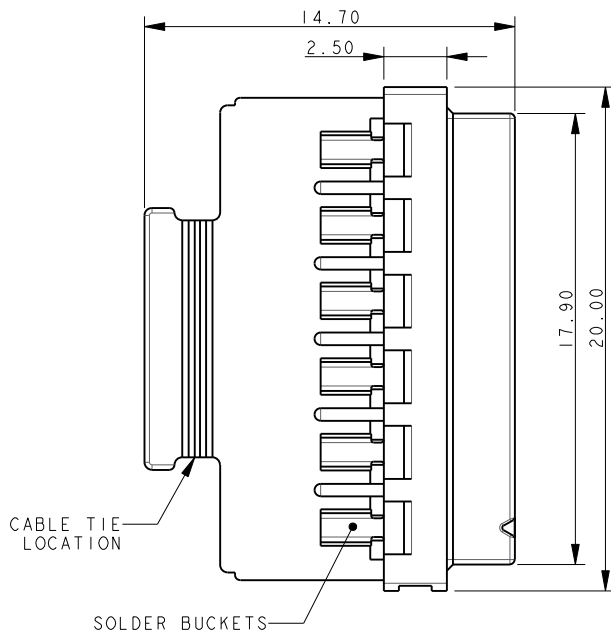

NOTES:

1. FOR MORE INFORMATION REFER TO PRODUCT SPEC 201-01-119.
2. CABLE TIE SUPPLIED FOR WIRE RETENTION, ATTACHED TO EACH REEL. SPARES CAN BE ORDERED, REFER TO PAGE 19.
3. DIMENSIONS ARE REFERENCE DIMENSIONS UNLESS TOLERANCED.
4. INSULATOR MATERIAL: NYLON 46. COLOR REFER TO PAGE 10.
5. CONTACT MATERIAL: COPPER ALLOY, SELECTIVE GOLD OVER NICKEL TIN PLATED ON TAILS.
6. PACKING IN TAPE AND REEL, QUANTITY PER REEL 700.
7. FOR ACCESSORY COVERS AND LATCHES REFER TO PAGES 16 AND 17.

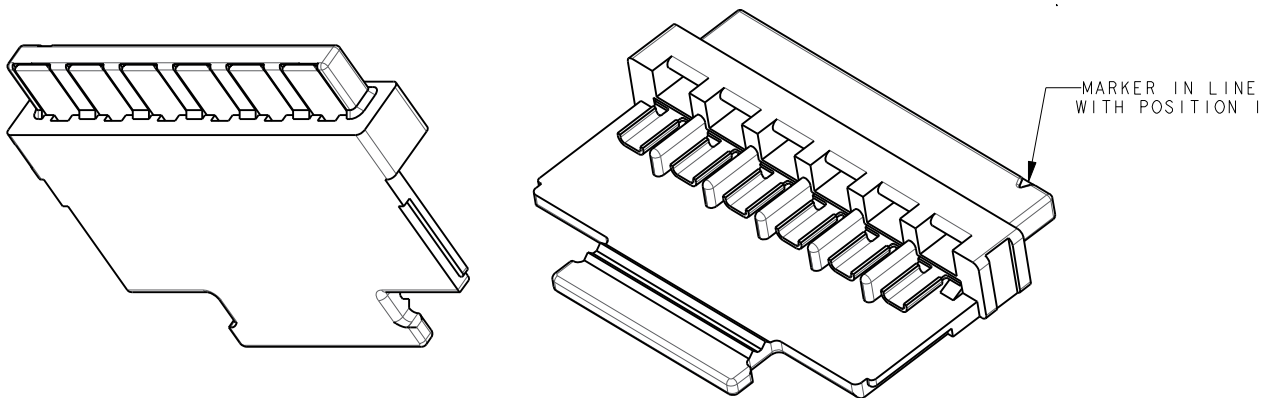

PACKING DETAILS CABLE TIES SUPPLIED WITH EACH REEL

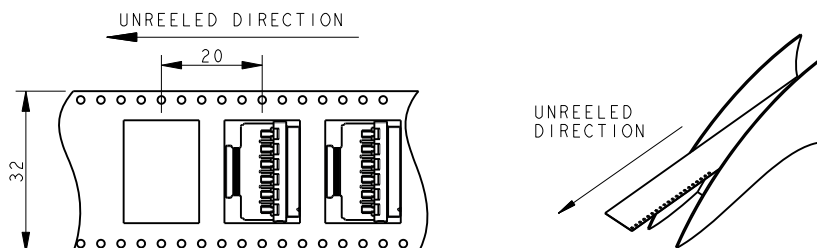

PLUG WIRED COVERS ACCESSORY NOT SUPPLIED WITH CONNECTOR ASSEMBLY

2 WAY COVER 60-9159-3302-0X-000

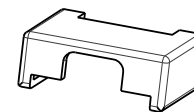
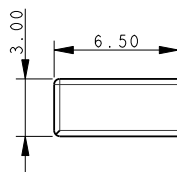
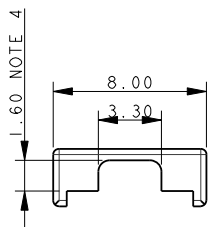

3 WAY COVER 60-9159-3303-0X-000

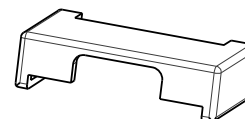
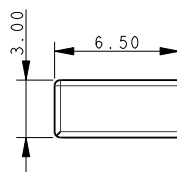
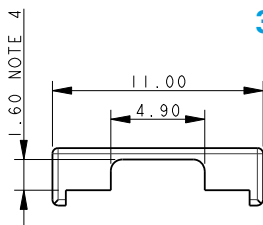

4 WAY COVER 60-9159-3304-0X-000

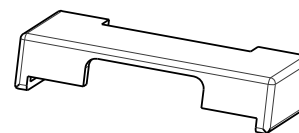
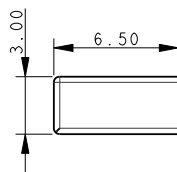
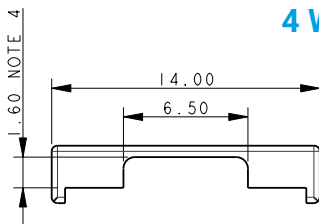

5 WAY COVER 60-9159-3305-0X-000

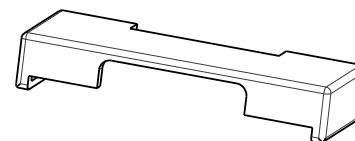
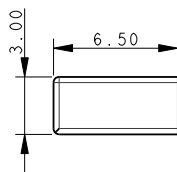
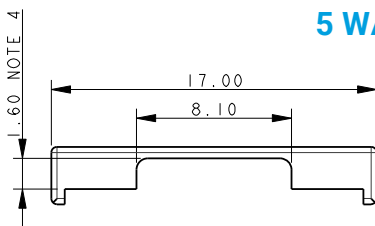

6 WAY COVER 60-9159-3306-0X-000

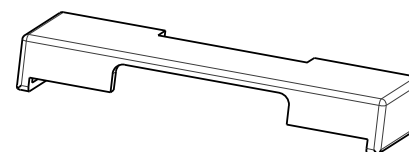
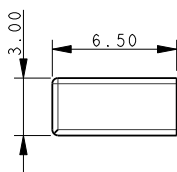
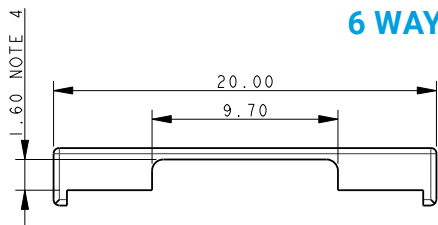

NOTES:

1. COVER (SLIDE ON) AVAILABLE TO PROTECT CABLE ENTRY.
2. OPTION COMPONENT. ORDER SEPARATELY.
3. PACKED IN BAGS, 1400 PIECES PER BAG.
4. MAXIMUM OUTER WIRE SIZE, 1.6MM DIAMETER INSULATION.
5. MATERIAL: GLASS FILLED NYLON 46. COLOR REFER TO PAGE 10.
6. COLOR OPTIONS SEE PAGE 10.
7. ALL DIMENSIONS ARE REFERENCED DIMENSIONS.
8. TO BE ASSEMBLED BEFORE CABLE TIE.

PLUG WIRED LATCHES ACCESSORY NOT SUPPLIED WITH CONNECTOR ASSEMBLY

LATCH 60-9159-3402-0X-000 USED ON 2, 4 AND 6 WAY ASSEMBLIES

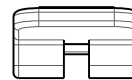
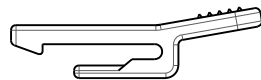
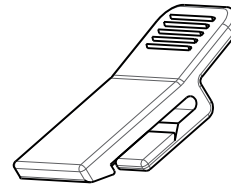
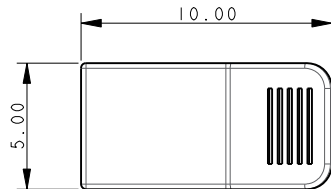

LATCH 60-9159-3403-0X-000 USED ON 3 AND 5 WAY ASSEMBLIES

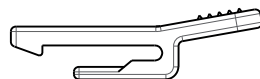
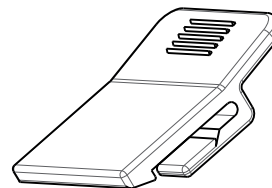
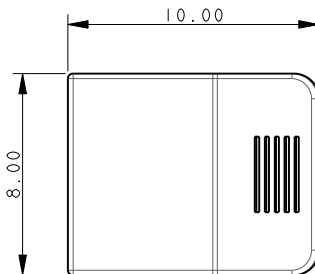

NOTES:

1. LATCH AVAILABLE TO RETAIN MATED PLUG.
2. OPTIONAL COMPONENT, ORDER SEPARATELY. SEE PAGE 19.
3. PACKAGED IN BAGS, 1400 PIECES PER BAG.
4. MATERIAL: GLASS FILLED NYLON 46. COLOR REFER TO PAGE 10.
5. ALL DIMENSIONS ARE REFERENCED DIMENSIONS.
6. TO BE ASSEMBLED BEFORE COVER.

Solder Cup Plug: 11-9159-WTB

2 & 3 Way Assembled



LATCH AND TIE DIMENSIONS WHEN ASSEMBLED 2 WAY ASSEMBLY

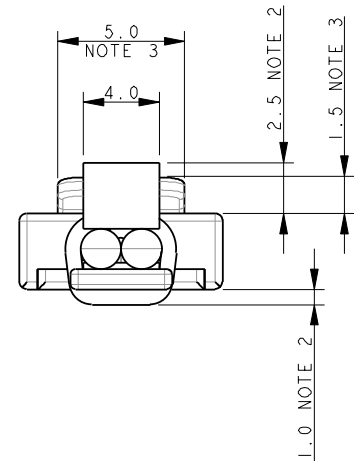
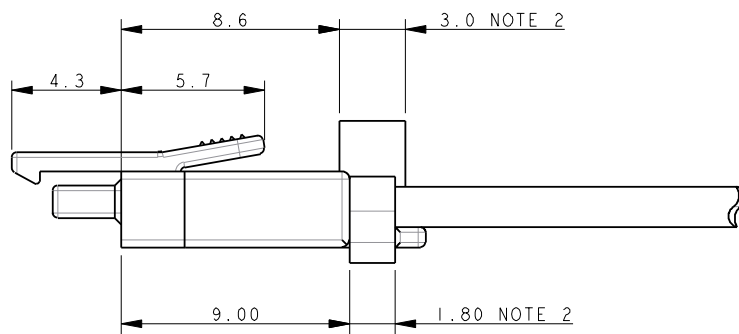

3 WAY ASSEMBLY

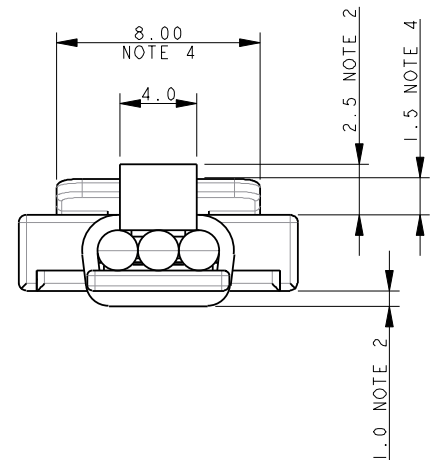
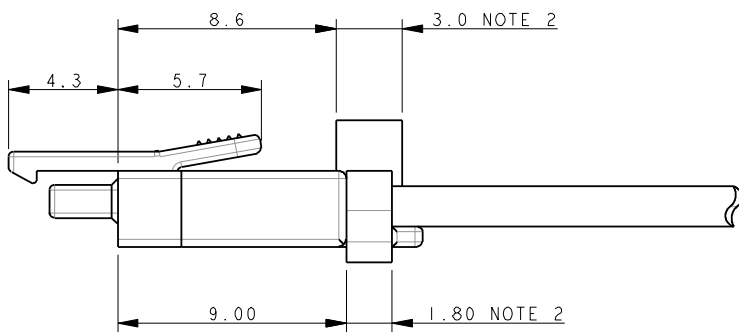

NOTES:

1. TO SHOW DIMENSIONS OF LATCH AND APPROXIMATE DIMENSIONS OF CABLE TIE DIMENSIONS WHEN ASSEMBLED.
2. CABLE TIE DIMENSIONS COMMON TO 2, 3, 4, 5 AND 6 WAY CONNECTORS.
3. 2 WAY LATCH ALSO USED ON 4 AND 6 WAY.
4. 3 WAY LATCH ALSO USED ON 5 WAY.

Solder Cup Plug: 11-9159-WTB

Accessory Ordering Codes / 3 Assembled Options

PLUG WIRED ACCESSORY ORDERING CODES

| Connector Assembly | Optional Components | |
|---------------------|---------------------|---------------------|
| Part Number | Cover (see page 16) | Latch (see page 17) |
| 11-9159-002-101-916 | 60-9159-3302-09-000 | 60-9159-3402-09-000 |
| 11-9159-003-101-916 | 60-9159-3303-09-000 | 60-9159-3403-09-000 |
| 11-9159-004-101-916 | 60-9159-3304-09-000 | 60-9159-3402-09-000 |
| 11-9159-005-101-916 | 60-9159-3305-09-000 | 60-9159-3403-09-000 |
| 11-9159-006-101-916 | 60-9159-3306-09-000 | 60-9159-3402-09-000 |

CABLE TIE

Supplied in bags with each reel of connector assemblies. Color White.
For additional ties order code 90-2211-7092-00-000. Packed in bags, 700 pieces per bag.

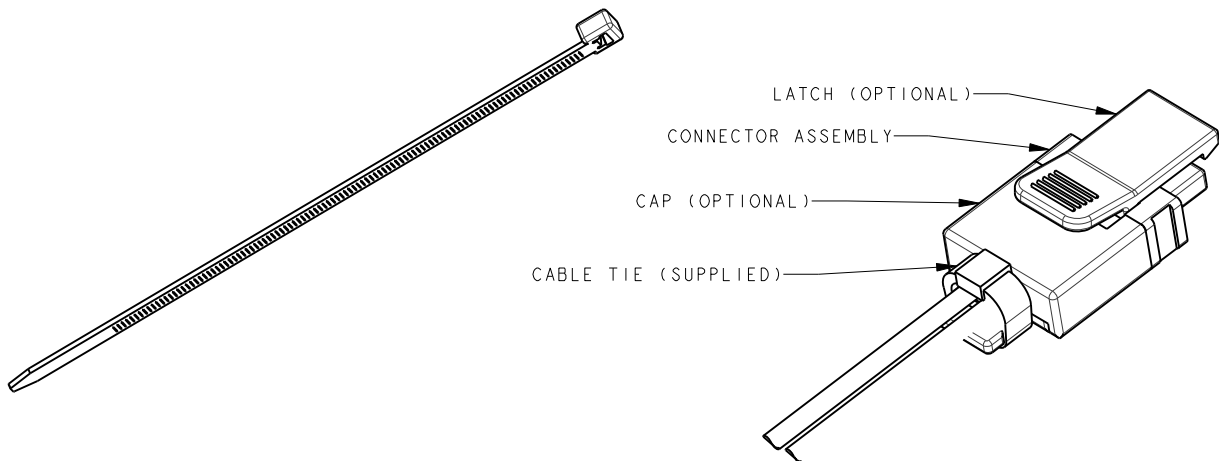

PLUG WIRED 3 ASSEMBLY OPTIONS

PLUG ASSEMBLY

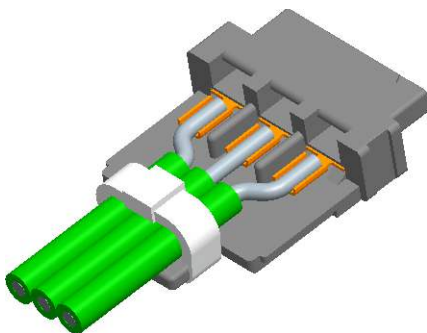

PLUG ASSEMBLY WITH COVER

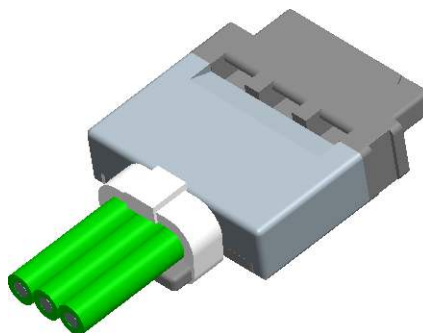

PLUG ASSEMBLY WITH COVER AND LATCH

