

Test Procedure for the NCV8664 Evaluation Board

ON Semiconductor®



5.16.2007

Table of required equipment:

Measurement equipment description	Concrete example	Quantity
Resistive Load	Agilent 6060B	1
Multimeters	Keithley 2000	2
NCV8664 Demo Board	-	1
DC Power Supply	Agilent 6812B	1

Please follow these steps during the first start of the NCV8664 evaluation board:

Dropout Voltage Verification Steps

1. Connect circuit as shown in Figure 1.
2. Set V_{in} = 13.5 V, Record V_{out} .
3. Reduce V_{in} until V_{out} has dropped by 100mV.
4. Subtract V_{out} from V_{in} . Resulting Voltage is Dropout Voltage.

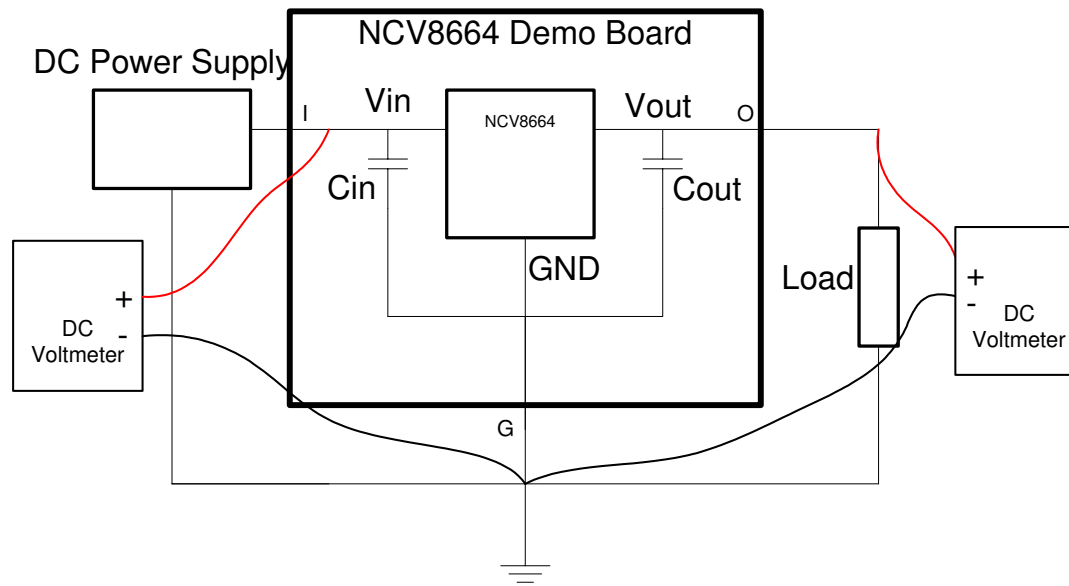
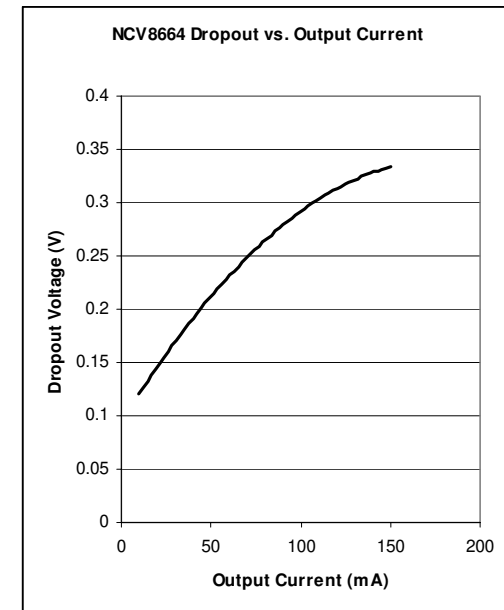

Figure 1- Dropout Voltage Test Setup



Quiescent Current Verification Steps

1. Connect circuit as shown in Figure 3.
2. Set $V_{in} = 13.5$ V.
3. Subtract Output Current from Input Current.

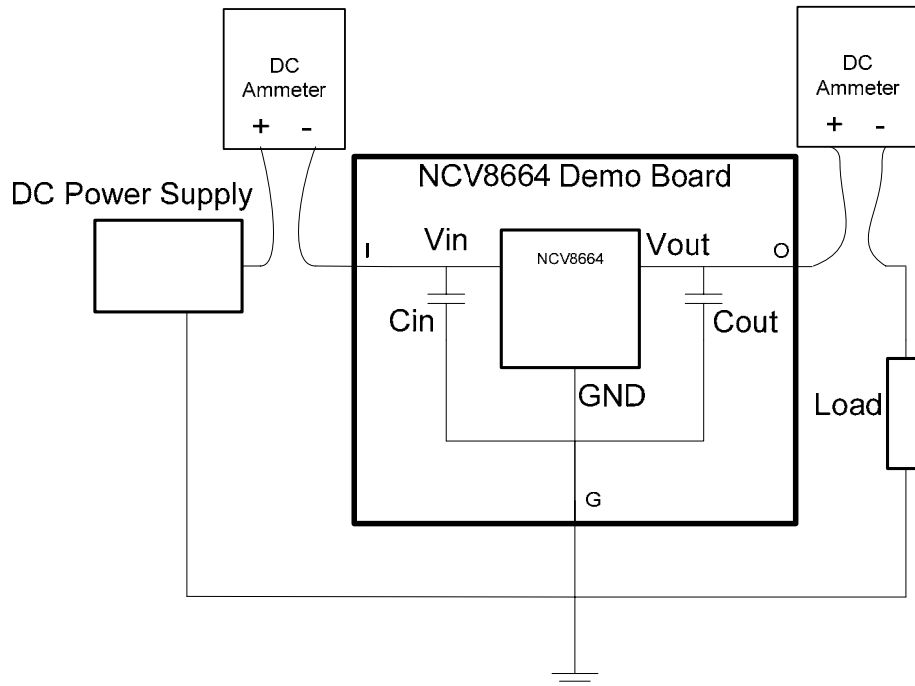
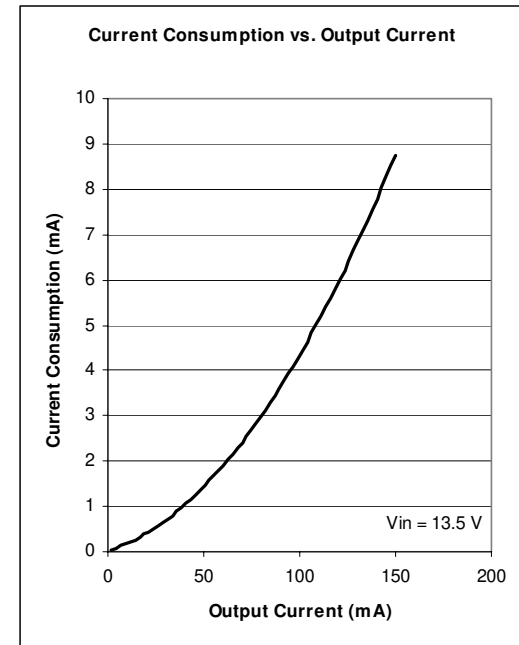

Figure 3. Quiescent Current Verification Setup



Output Voltage Verification Steps

1. Connect circuit as shown in Figure 4.
2. Set output load to 100 Ohms, Set $V_{in} = 0\text{ V}$, Record V_{out} .
3. Increase V_{in} , measure V_{out} .

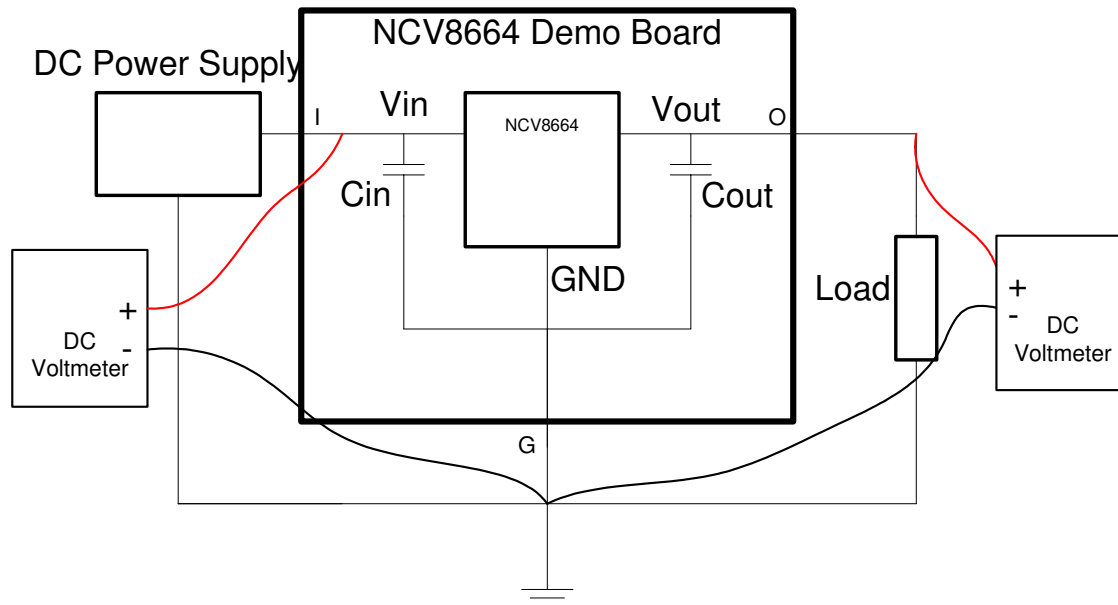

Figure 4. Quiescent Current Verification Setup

