

LOC	DIST	P	F	ZONE	LTR	REVISIONS	DATE	APPD	
G	14					D	REVISED PER 0720-0436-94	01DEC94	OKS DAP

METRIC
 DIMENSIONS LISTED IN mm [INCHES]

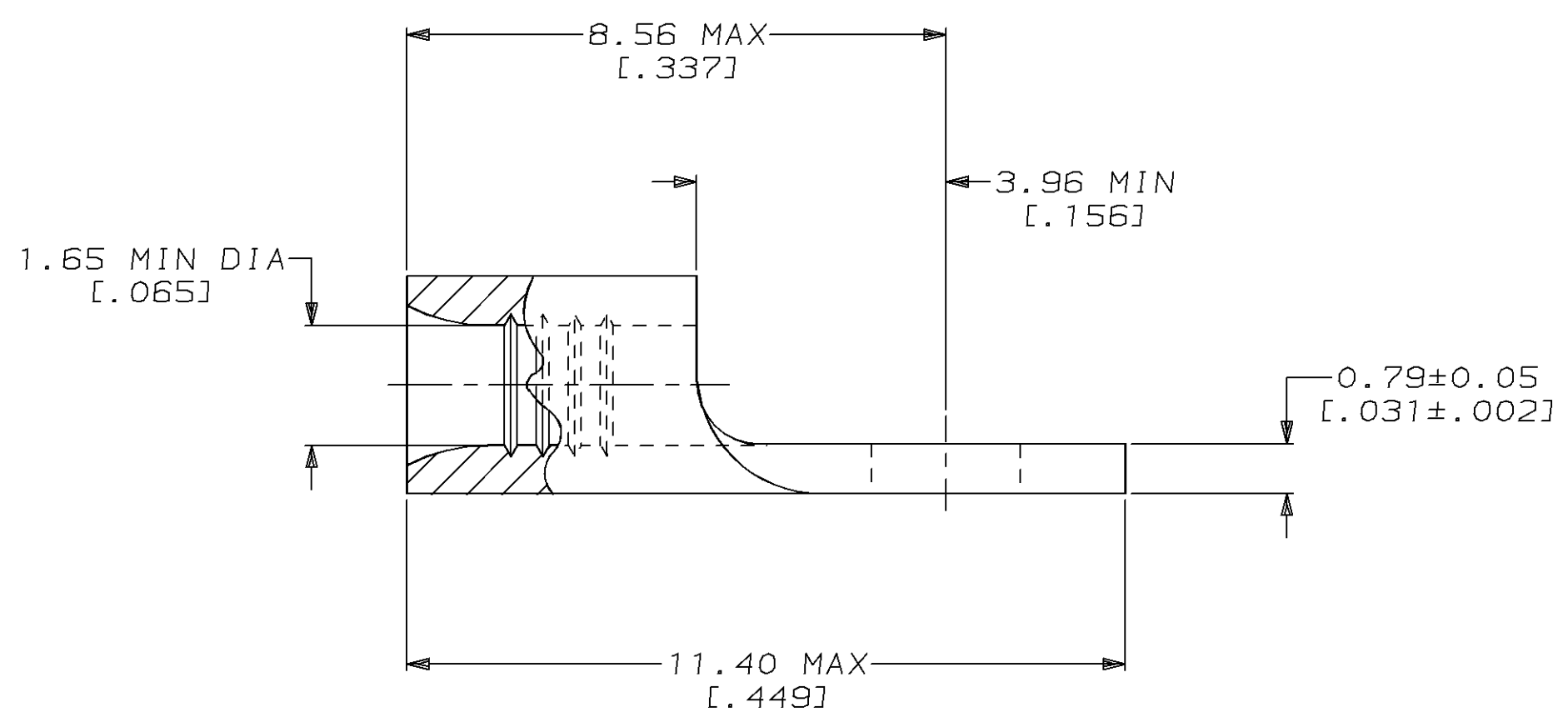
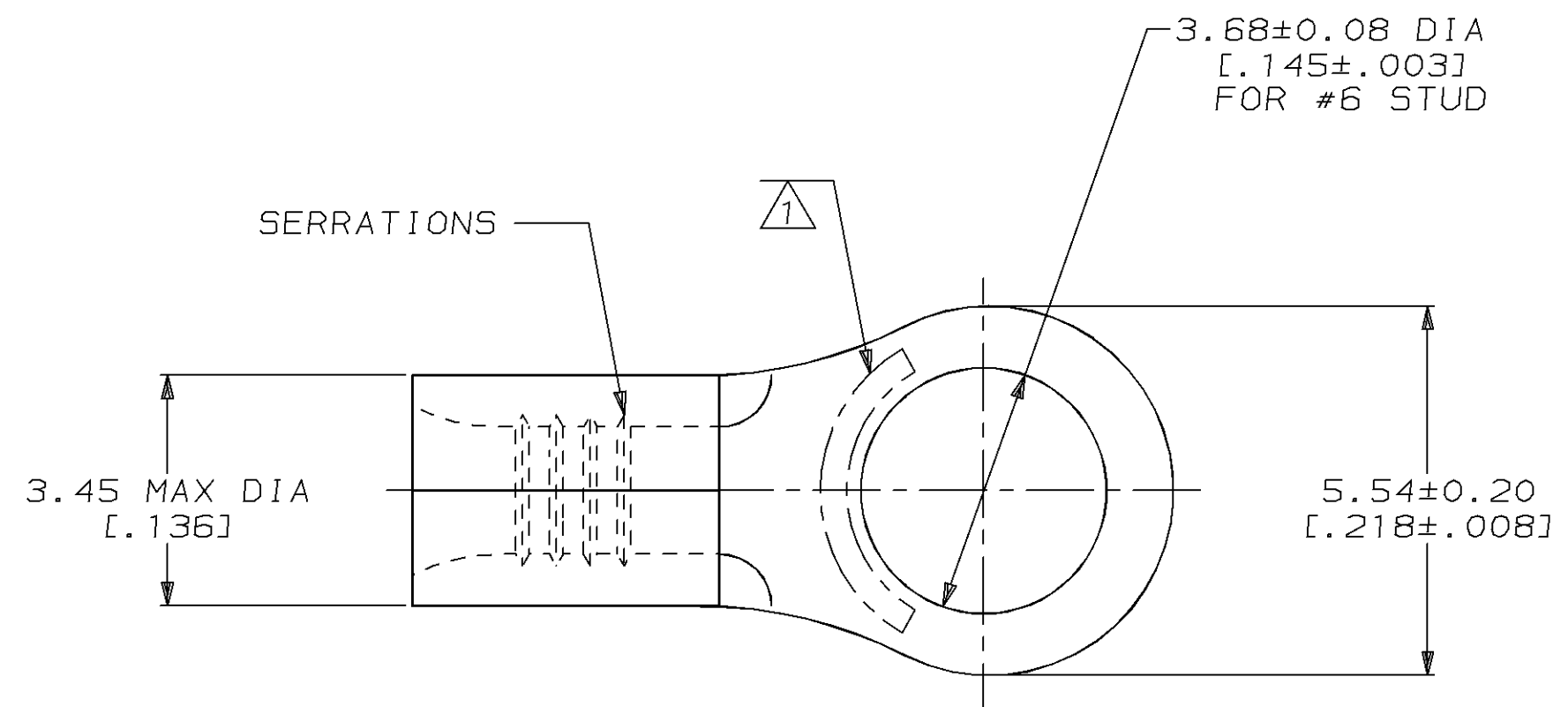

AMP WIRE RANGE	UL E13288 Listed
22-16 AWG STRANDED	22-16 AWG STRANDED
SR LR7189 Certified	MILITARY P/N AND CLASS
NOT CERTIFIED	NOT APPLICABLE

- ① STAMP AMP 22-18* APPROX AS SHOWN
22-16 TERMINALS ARE STAMPED 22-18 IN
ACCORDANCE WITH MILITARY SPEC MIL-T-7928
COMMERCIAL WIRE RANGE IS 22-16
- ② TIN PL 0.00254 [.000100] MIN THK
PER MIL-T-10727
- ③ GOLD PL 0.00127 [.000050] MIN THK
PER MIL-G-45204 OVER NICKEL PL
0.00076 [.000030] MIN THK PER QQ-N-290

③	3-31091-8
②	31091
FINISH	PART NO

AMP INCORPORATED
CUSTOMER SERVICE SYSTEMS

FOR ADDITIONAL
 PRODUCT INFORMATION OR
 COPIES OF DRAWINGS
 AND TECHNICAL DOCUMENTS

FOR APPLICATION
 TOOLING INFORMATION

FOR ORDER ENTRY

PRODUCT INFORMATION CENTER
 1-800-522-6752

TOOLING ASSISTANCE CENTER
 1-800-722-1111

1-800-526-5142

MAX RECOMMENDED OPERATING
 TEMPERATURE:
 170°C MAX

VOLTAGE RATING:
 NOT APPLICABLE

WIRE CROSS SECTIONAL AREA RANGE:
 0.26-1.65mm² [509-3,260] CIR MILS
 STRANDED

THIS DRAWING IS A CONTROLLED DOCUMENT FOR
 AMP INCORPORATED. IT IS SUBJECT TO CHANGE
 AND THE CONTROLLING ENGINEERING ORGANIZATION
 SHOULD BE CONTACTED FOR THE LATEST REVISION.

DO NOT SCALE PRINT.
 UNLESS SPECIFIED
 DIMENSIONS IN mm [INCHES]
 TOLERANCES ON:

2 PLC DEC ± -
 3 PLC DEC ± -
 ANGLES ± -

MATERIAL
 COPPER PER
 ASTM B-152
 ANNEALED

FINISH
 SEE TABLE

DR 1-27-93
 TA BRINKMAN

CHK 1-27-93
 DA PATTERSON

APPD 1-27-93
 DE MILLER

APPD 1-27-93
 JL MECKLEY

PRODUCT SPEC
 -

APPLICATION SPEC
 -

WEIGHT
 -

AMP AMP Incorporated
 Harrisburg, PA 17105-3608

NAME
**TERMINAL, RING TONGUE,
 BUDGET**

SIZE CAGE CODE DRAWING NO
 C 00779 C=31091

SCALE 10:1 SHEET 1 OF 1