



OVM6946 400 x 400 product brief



Compact, Cost-Effective Wafer-Level Camera Module for Single-Use Endoscopes



available in
a lead-free
package

OmniVision's OVM6946 is a compact camera module for medical applications such as minimally-invasive endoscopes. The 1/18-inch OVM6946 utilizes OmniVision's market-proven CameraCubeChip® wafer-level module technology to streamline manufacturing processes and shorten time-to-market, and is the industry's most cost-effective single-chip imaging solution for single-use endoscopes.

Built on OmniVision's OmniBSI™+ pixel architecture, the OVM6946 captures high quality 400 x 400 resolution video at 30 frames per second (fps). The OVM6946 comes in compact 1.10 mm x 1.10 mm packages with z-heights of 2.37 or 2.27 mm, enabling a 90° or 120° diagonal field of view. The OVM6946 is well-suited to a wide range of endoscope applications, including medical, veterinarian, and industrial.

Find out more at www.ovt.com.



Applications

- Medical, Dental, Veterinarian, Industrial Endoscopes

Product Features

- optical size of 1/18"
- non-autoclavable
- analog output
- automatic/manual control of exposure and gain
- on-chip PLL
- low power consumption
- single 3.3V power supply
- serial peripheral interface (SPI)
- OmniBSI™+ pixel structure using 0.11 μm process
- extra black coating versions available

OVM6946



Ordering Information

- **OVM6946-RAJA** (color, lead-free)
4-pin 160k CameraCubeChip®, LA silicon, 120° DFOV
- **OVM6946-RANA** (color, lead-free)
4-pin 160k CameraCubeChip®, LA silicon, 90° DFOV
- **OVM6946-RAJA-1B** (color, lead-free)
4-pin 160k CameraCubeChip®, HK silicon, 120° DFOV
- **OVM6946-RANA-1B** (color, lead-free)
4-pin 160k CameraCubeChip®, HK silicon, 90° DFOV

Technical Specifications

- **active array size:** 400 x 400
- **frame rate:**
- 160 Kpixel (400x400): 30 fps
- **power supply:**
- analog: 3.3V ± 5%
- **power requirements:**
25 mW (with IO consumption)
- **temperature range:**
- **operating:** -20°C to +70°C junction temperature
- **stable image:** 0°C to +50°C junction temperature
- **output formats:** analog signal output
- **lens size:** 1/18"
- **diagonal field of view (FOV):**
- RAJA: 120° ±3°
- RANA: 90° ±3°
- **f no.:**
- RAJA: 5.0
- RANA: 4.0
- **focal length:**
- RAJA: 0.418 mm
- RANA: 0.505 mm
- **scan mode:** progressive
- **color mosaic:** RGB Bayer pattern
- **pixel size:** 1.75 μm x 1.75 μm
- **image area:** 714 μm x 707 μm
- **net weight:**
- RAJA: 4.62 mg
- RANA: 4.587 mg
- **package dimensions (including ball height):**
- RAJA: 1100 x 1100 x 2266 μm
- RANA: 1100 x 1100 x 2362 μm

Functional Block Diagram

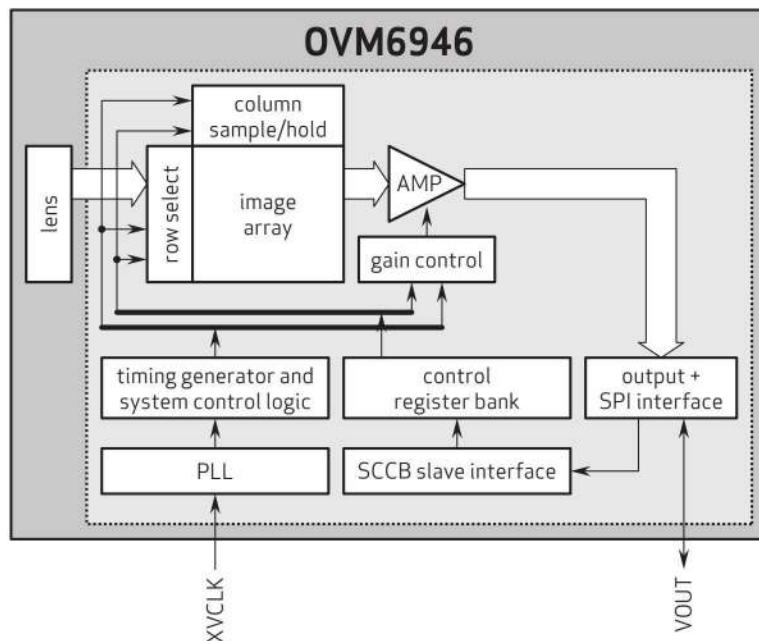

4275 Burton Drive
Santa Clara, CA 95054
USA

Tel: +1 408 567 3000
Fax: +1 408 567 3001
www.ovt.com

OmniVision reserves the right to make changes to their products or to discontinue any product or service without further notice. OmniVision, the OmniVision logo, and CameraCubeChip are registered trademarks of OmniVision Technologies, Inc. OmniBSI is a trademark of OmniVision Technologies, Inc. All other trademarks are the property of their respective owners.



OmniVision