

LOC	DIST	REVISIONS					
GP	00	P	LTN	DESCRIPTION	DATE	DMN	APVD
		8		UPDATE DEFAULT TOLERANCE	3APR2014	RG	MC
		9		ADD APPLICATION SPEC	6NOV2014	RG	MC
		10		ADD 2085945-8	18MAY2015	RG	SH
		11		UPDATE SHEET 4 FACE PLATE VIEW	2SEP2015	RG	SH

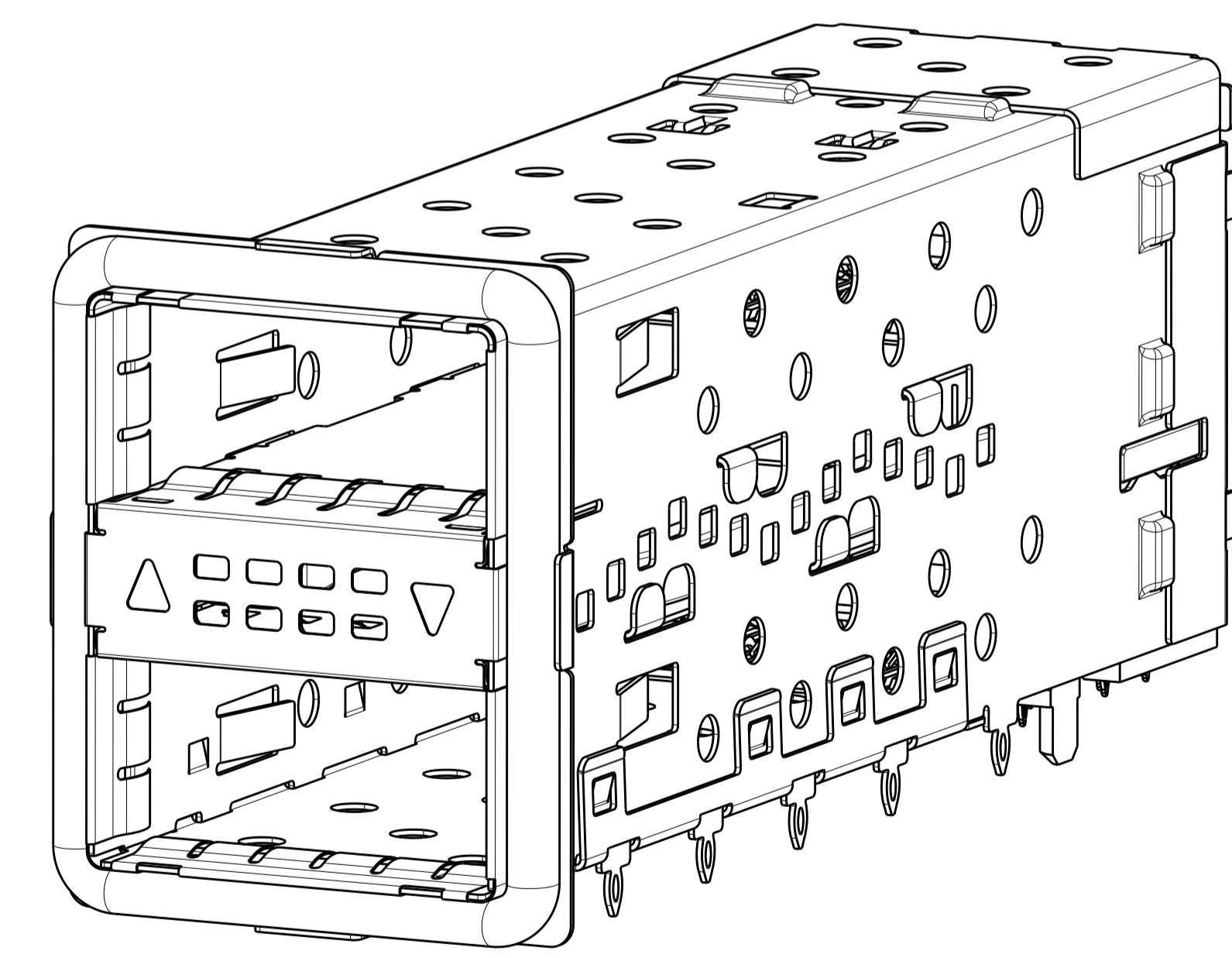
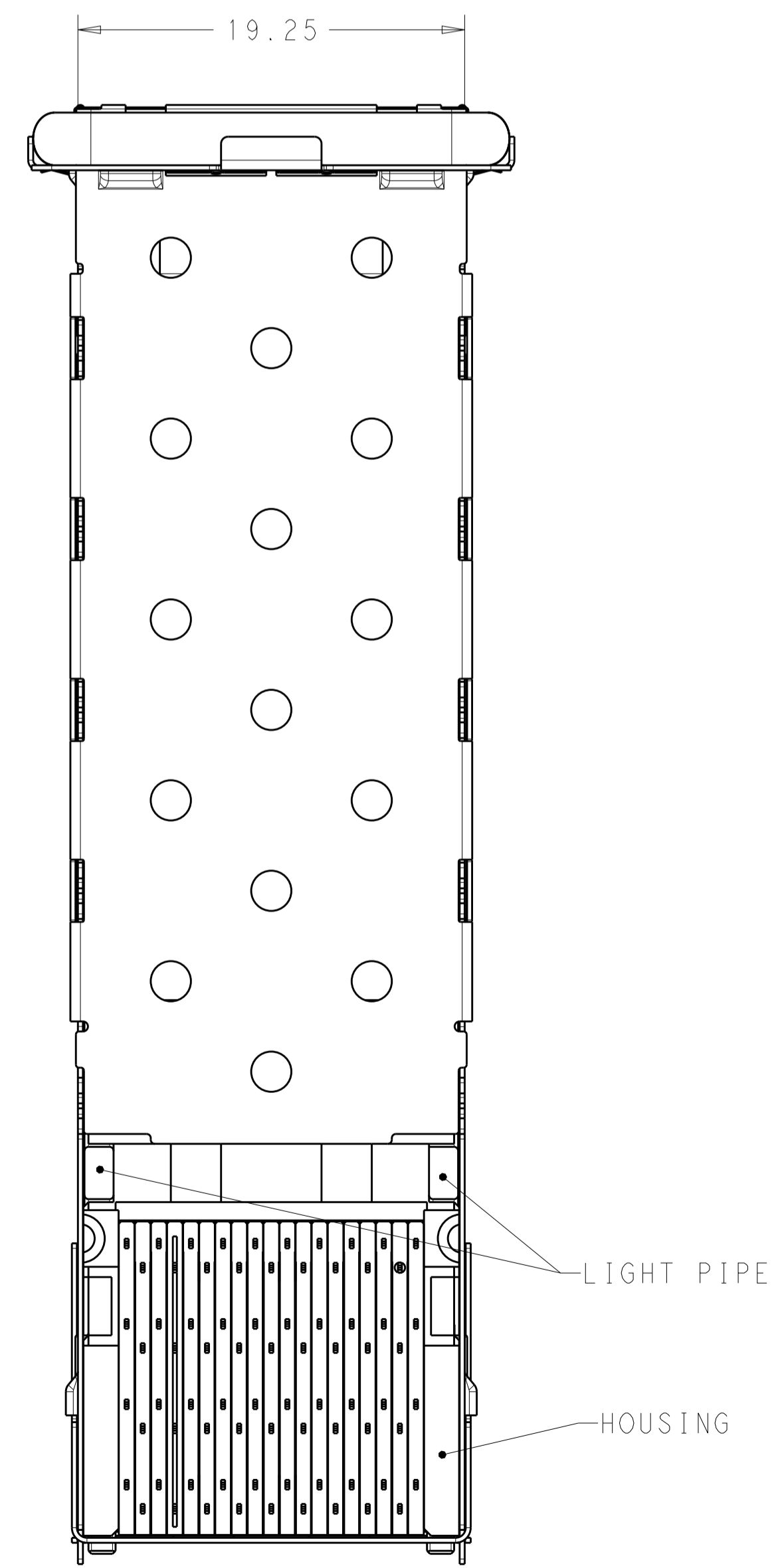
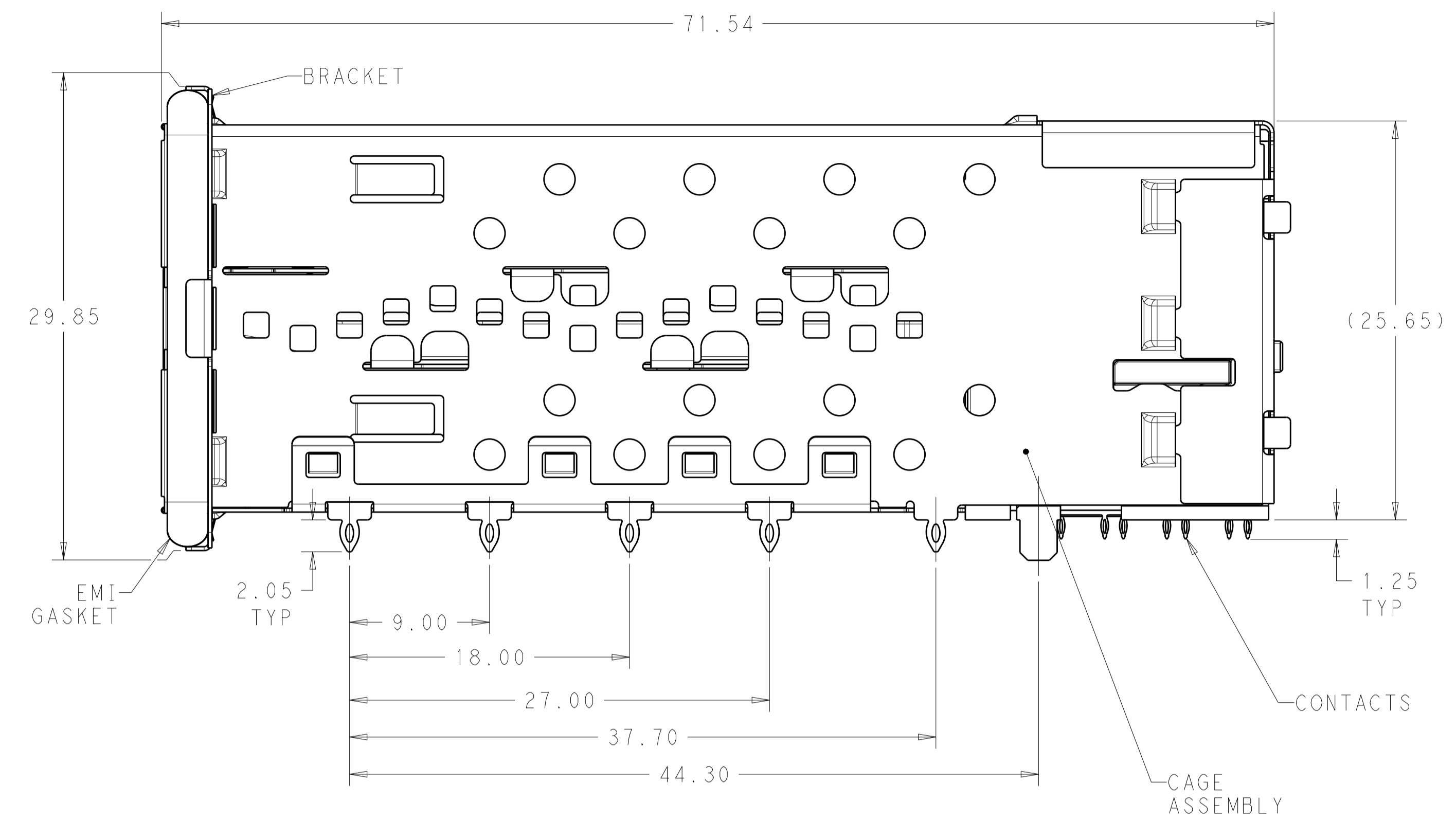
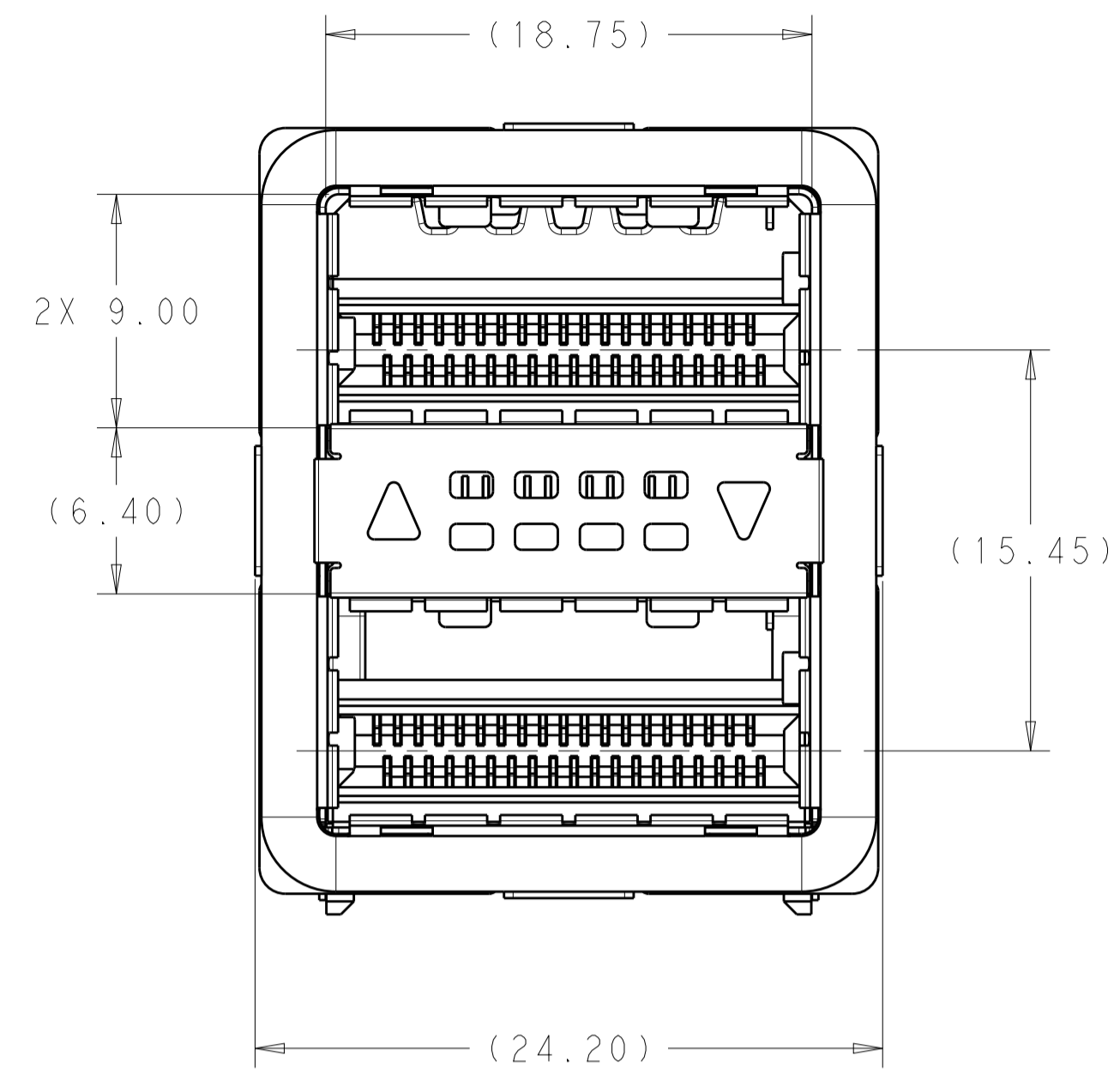

2085945-1 SHOWN  
SCALE 4:1

- 1 MATERIALS:  
 CAGE ASSEMBLY- NICKEL SILVER ALLOY PER ASTM B 122.  
 BRACKET- STAINLESS STEEL.  
 EMI GASKET- NICKEL-GRAPHITE FILLED SILICONE.  
 HOUSING- BLACK LCP, UL 94V-0 RATED.  
 CHICKLET- BLACK LCP, UL 94V-0 RATED.  
 LIGHT PIPE- POLYCARBONATE, CLEAR, UL 94V-2 RATED.  
 CONTACT- COPPER ALLOY.
- 2 DATUM AND BASIC DIMENSIONS ESTABLISHED BY CUSTOMER.
- 3. MINIMUM PCB THICKNESS OF 1.57mm.
- 4 CONTACT FINISH- CONFORMS TO THE REQUIREMENTS OF TE PRODUCT SPECIFICATION 108-127010, BASED ON EIA/ECA-364-1000.01A, (CONTROLLED ENVIRONMENT APPLICATIONS) ON MATING INTERFACE, TIN ON NEEDLE EYE.
- 5 THE ENTIRE AREA OF THE CONNECTOR FOOTPRINT, INDICATED BY THE DASHED LINE, TO BE CONSIDERED THE KEEPOUT AREA FOR COMPONENTS AND SIGNAL TRACES, TOP SIDE ONLY. TOP SIDE TRACES ALLOWED WITHIN CONNECTOR HOLE PATTERN.
- 6 LIGHT PIPE PAD LAYOUT IS FOR 0805 LOW PROFILE LED PACKAGE WITH A HEIGHT OF 0.8mm.

DESCRIPTION	PART NUMBER
OUTER LIGHT PIPES WITH CUSTOMIZED GASKET	2085945-8
BOTH LIGHT PIPES	2085945-7
INNER LIGHT PIPES	2085945-6
OUTER LIGHT PIPES	2085945-5
NO LIGHT PIPES	2085945-4
BOTH LIGHT PIPES	2085945-3
INNER LIGHT PIPES	2085945-2
OUTER LIGHT PIPES	2085945-1

THIS DRAWING IS A CONTROLLED DOCUMENT.		DMN B. MCMASTER 08AUG11	TE Connectivity NAME CAGE AND PT CONNECTOR ASSEMBLY, WITH EMI GASKET, PRESS FIT, 2X1, STACKED QSFP+	
DIMENSIONS: mm		CHK E. WICKES 08AUG11		
TOLERANCES UNLESS OTHERWISE SPECIFIED:		APVD E. WICKES 08AUG11	PRODUCT SPEC 108-127010	
0 PLC ± 1 PLC ±0.30 2 PLC ±0.25 3 PLC ± 4 PLC ± ANGLES ±		APPLICATION SPEC 114-32020	SIZE A100779C=2085945	
MATERIAL		WEIGHT	RESTRICTED TO	
FINISH		CUSTOMER DRAWING	SCALE 4:1 SHEET 1 OF 4 REV 11	

LOC	DIST	REV	DATE	BY	APPV
GP	00				

REVISONS		DATE	BY	APPV
1	SEE SHEET 1			

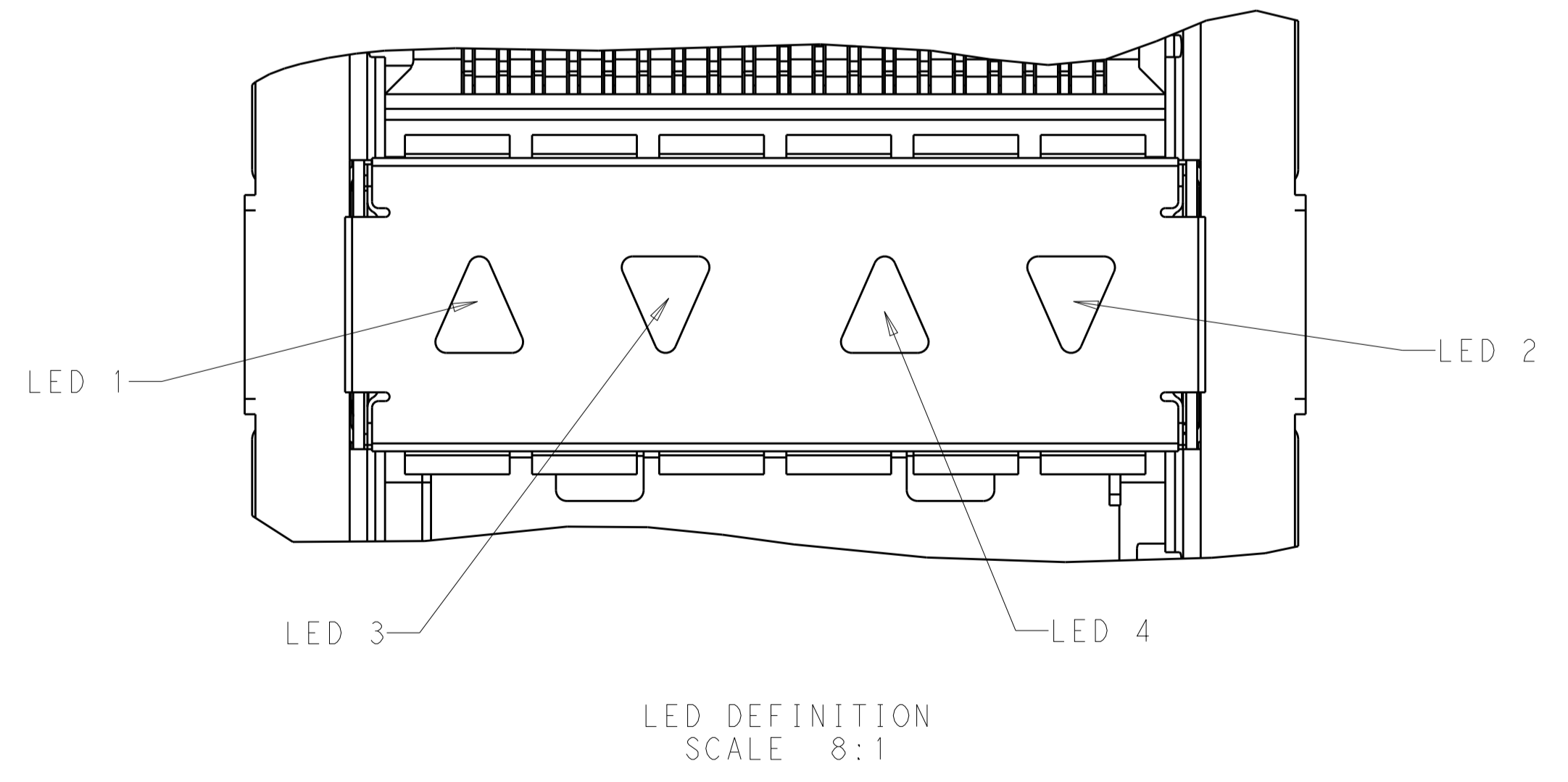
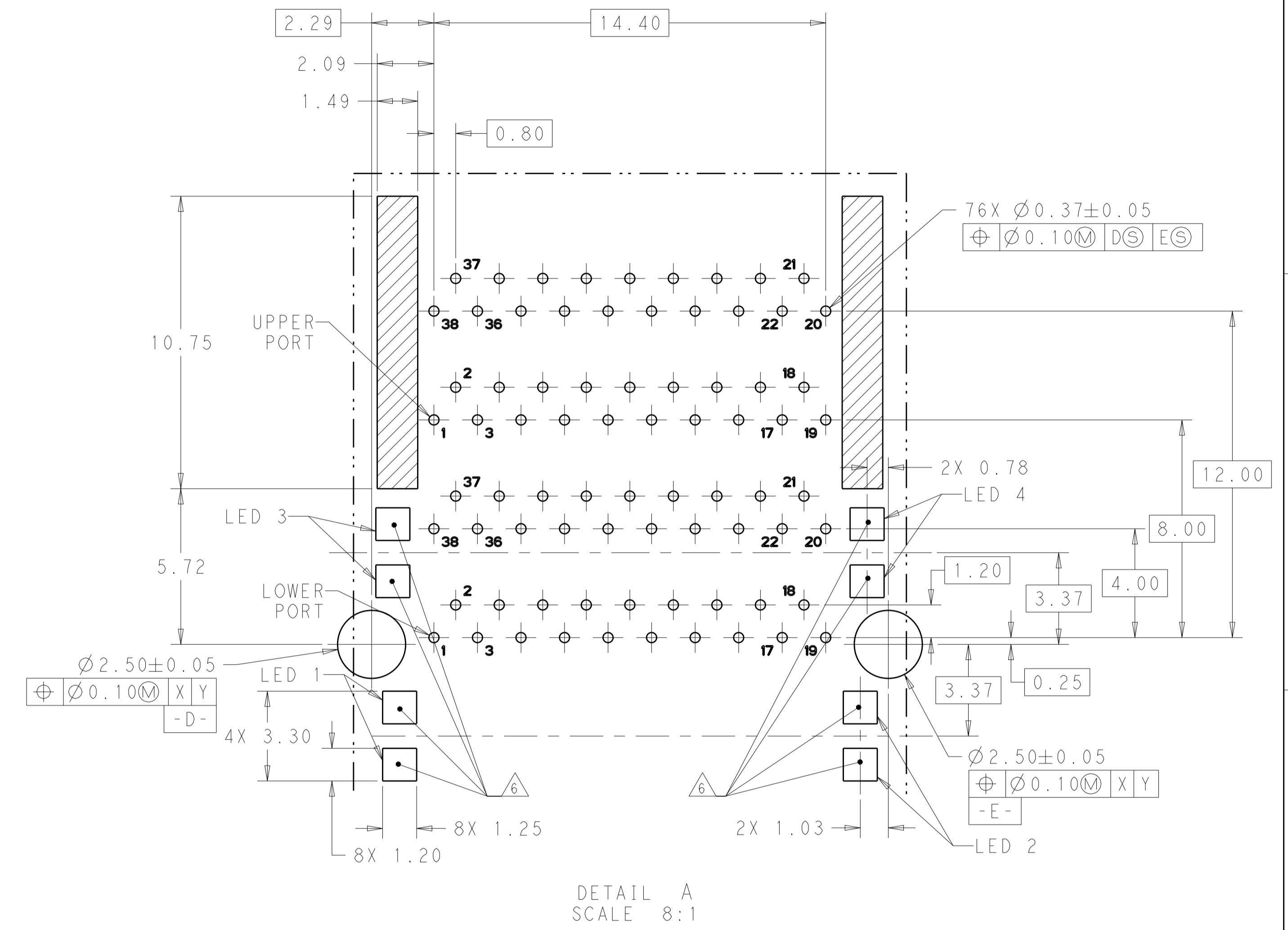
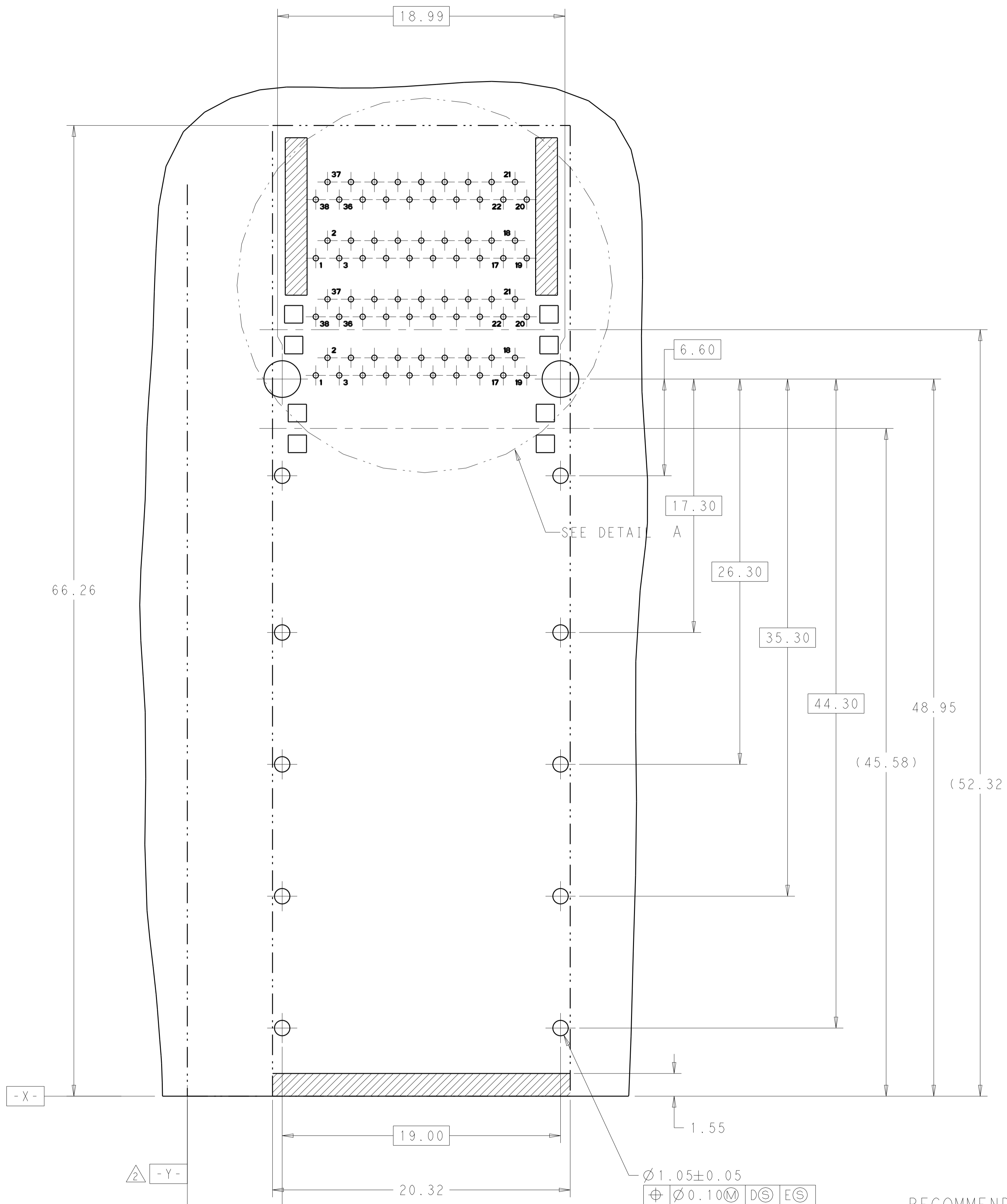

RECOMMENDED PCB LAYOUT  
 COMPONENT SIDE OF BOARD  
 SCALE 4:1

THIS DRAWING IS A CONTROLLED DOCUMENT.		OWN: B. MCMASTER 08AUG11	TE Connectivity
DIMENSIONS: mm		CHK: E. WICKES 08AUG11	
TOLERANCES UNLESS OTHERWISE SPECIFIED:		APPV: E. WICKES 08AUG11	NAME: CAGE AND PT CONNECTOR ASSEMBLY, WITH EMI GASKET, PRESS FIT, 2X1, STACKED QSFP+
0 PLC ±	1 PLC ±0.30	PRODUCT SPEC	SIZE: CAGE CODE DRAWING NO. RESTRICTED TO
2 PLC ±0.25	3 PLC ±	108-127010	A100779C=2085945
4 PLC ±	ANGLES ±	APPLICATION SPEC	SCALE 4:1 SHEET 2 OF 4 REV 11
MATERIAL FINISH	WEIGHT	114-32020	CUSTOMER DRAWING

LOC		DIST		REVISIONS			
P	LTN	DESCRIPTION	DATE	DMN	APVD		
-	-	SEE SHEET 1	-	-	-		

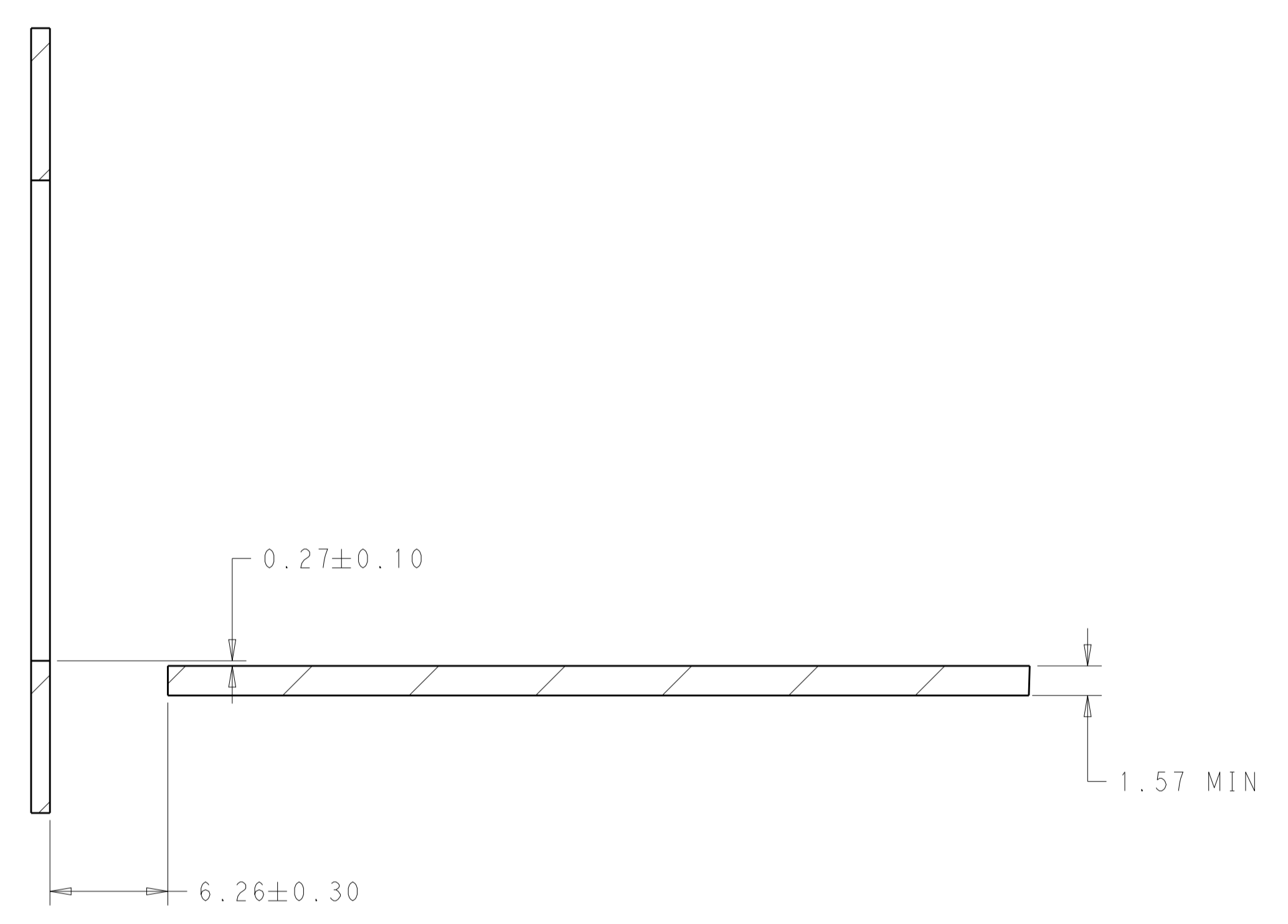
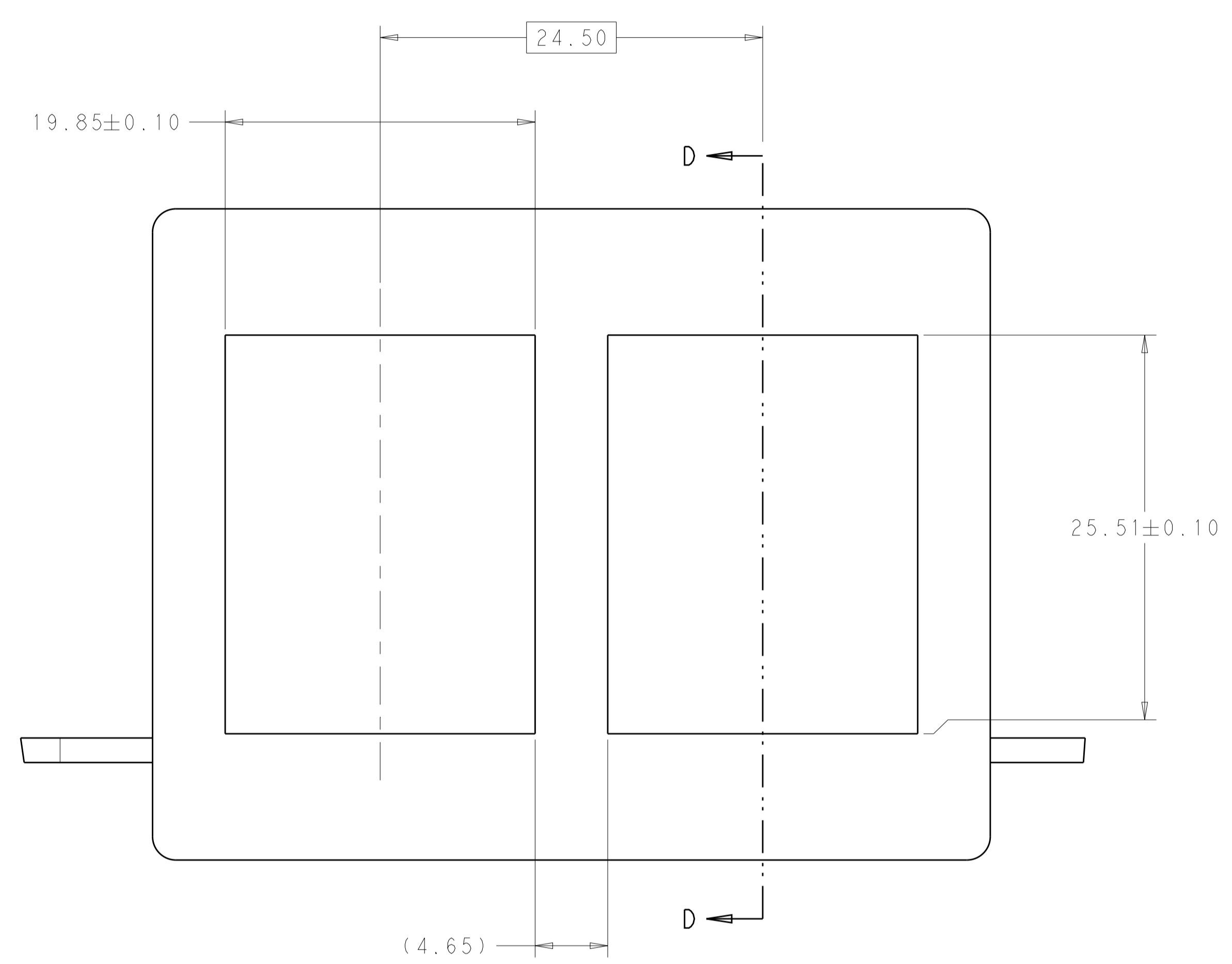

SECTION D-D

RECOMMENDED PANEL CUTOUT  
 AND PC BOARD, PANEL POSITION  
 SCALE 4:1

THIS PRINT IS  
**PRELIMINARY**  
 UNQUALIFIED PRODUCT  
 CONTACT PRODUCT ENGINEERING  
 BEFORE USING THIS PRINT

THIS DRAWING IS A CONTROLLED DOCUMENT.		DMN B. MCMASTER 08AUG11	TE Connectivity
DIMENSIONS:		CHK E. WICKES 08AUG11	
mm	TOLERANCES UNLESS OTHERWISE SPECIFIED:	APVD E. WICKES 08AUG11	NAME CAGE AND PT CONNECTOR ASSEMBLY, WITH EMI GASKET, PRESS FIT, 2X1, STACKED QSFP+
0 PLC ±	1 PLC ±0.30	PRODUCT SPEC	
2 PLC ±0.25	3 PLC ±	108-127010	SIZE CAGE CODE DRAWING NO RESTRICTED TO A100779C=2085945
4 PLC ±	ANGLES ±	APPLICATION SPEC	
MATERIAL	FINISH	114-32020	CUSTOMER DRAWING SCALE 4:1 SHEET 3 OF 4 REV 11
		WEIGHT	

LOC		DIST		REVISONS			
GP	00	P	LYR	DESCRIPTION	DATE	DMN	APVD
				SEE SHEET 1			

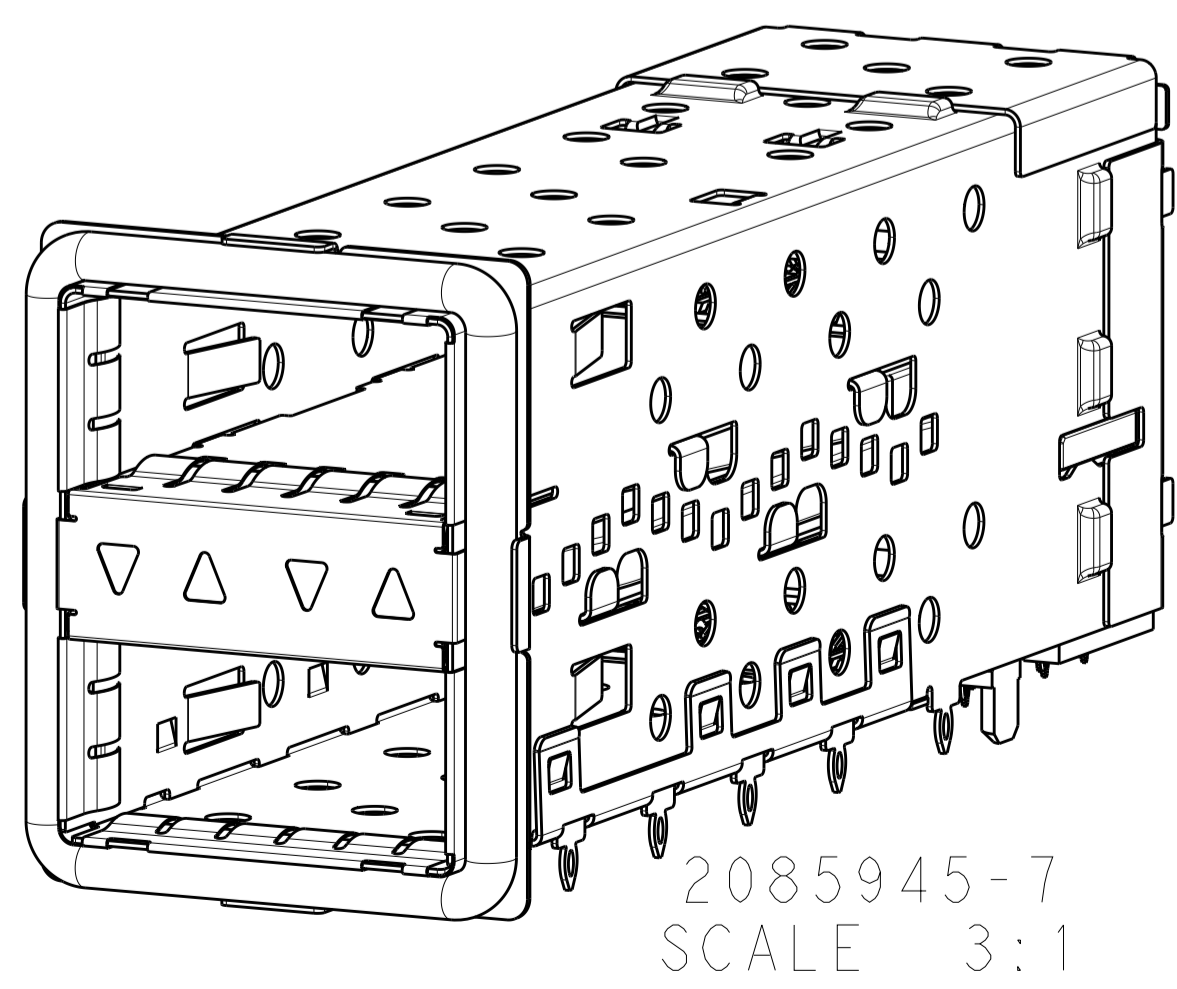
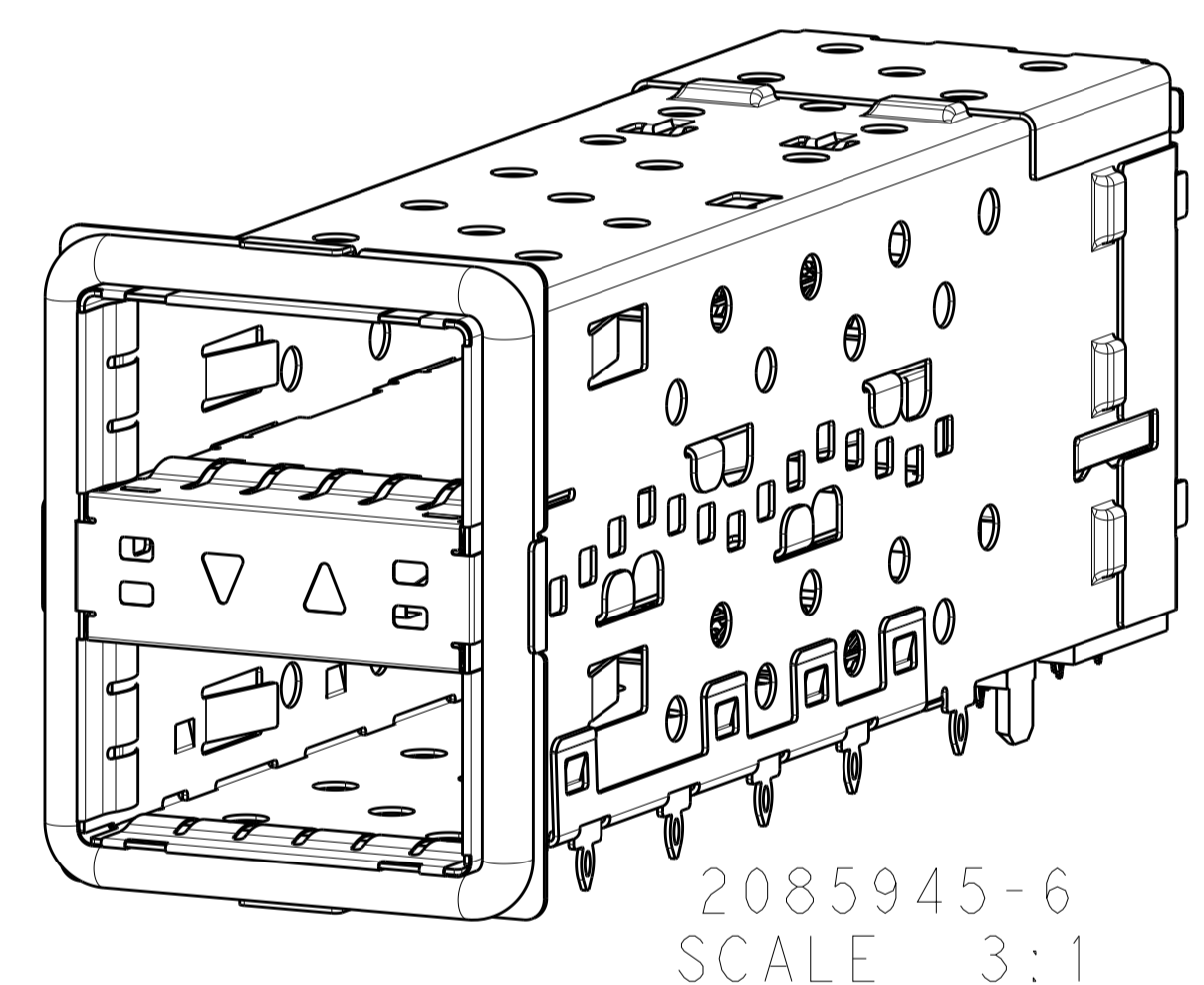
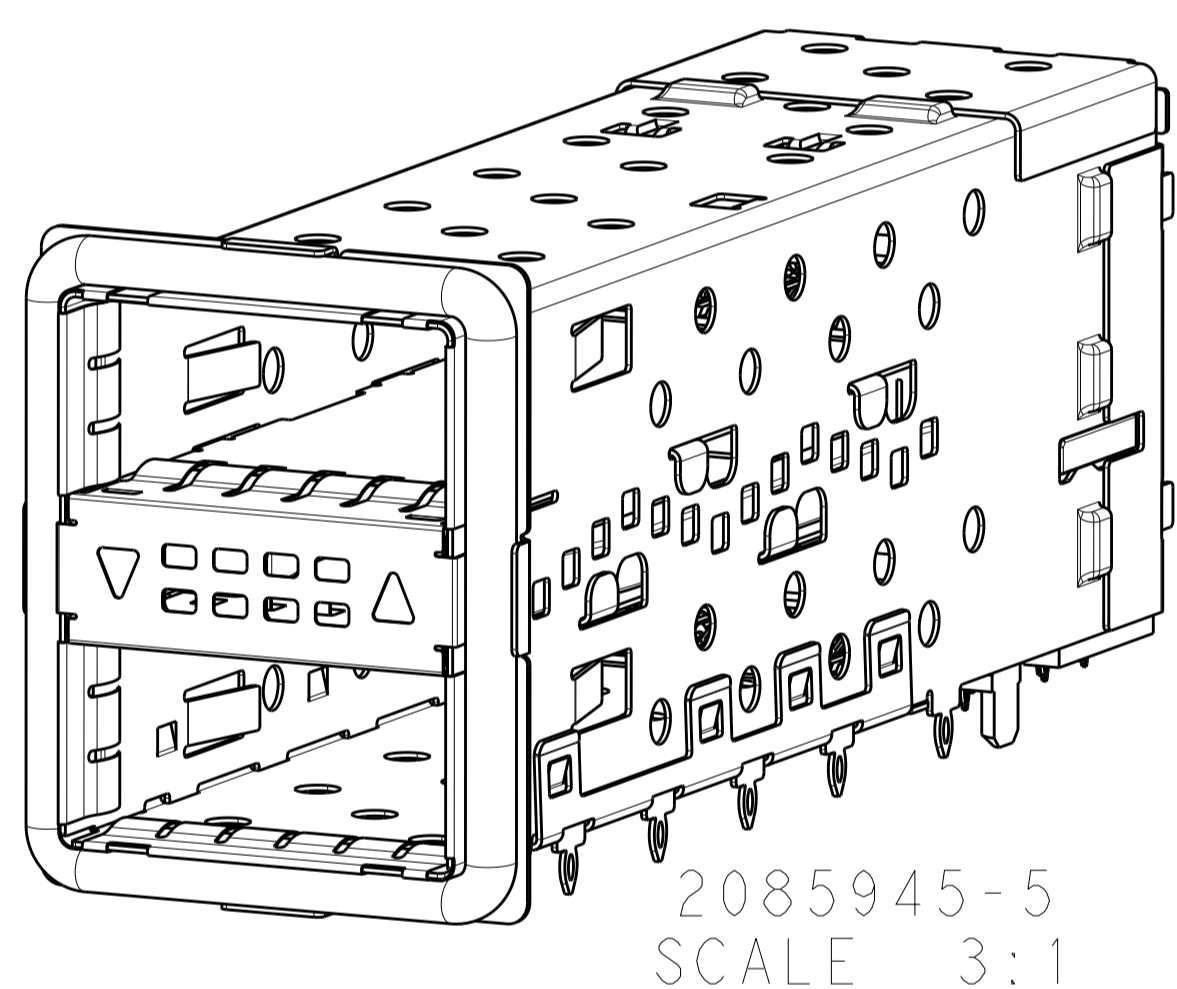
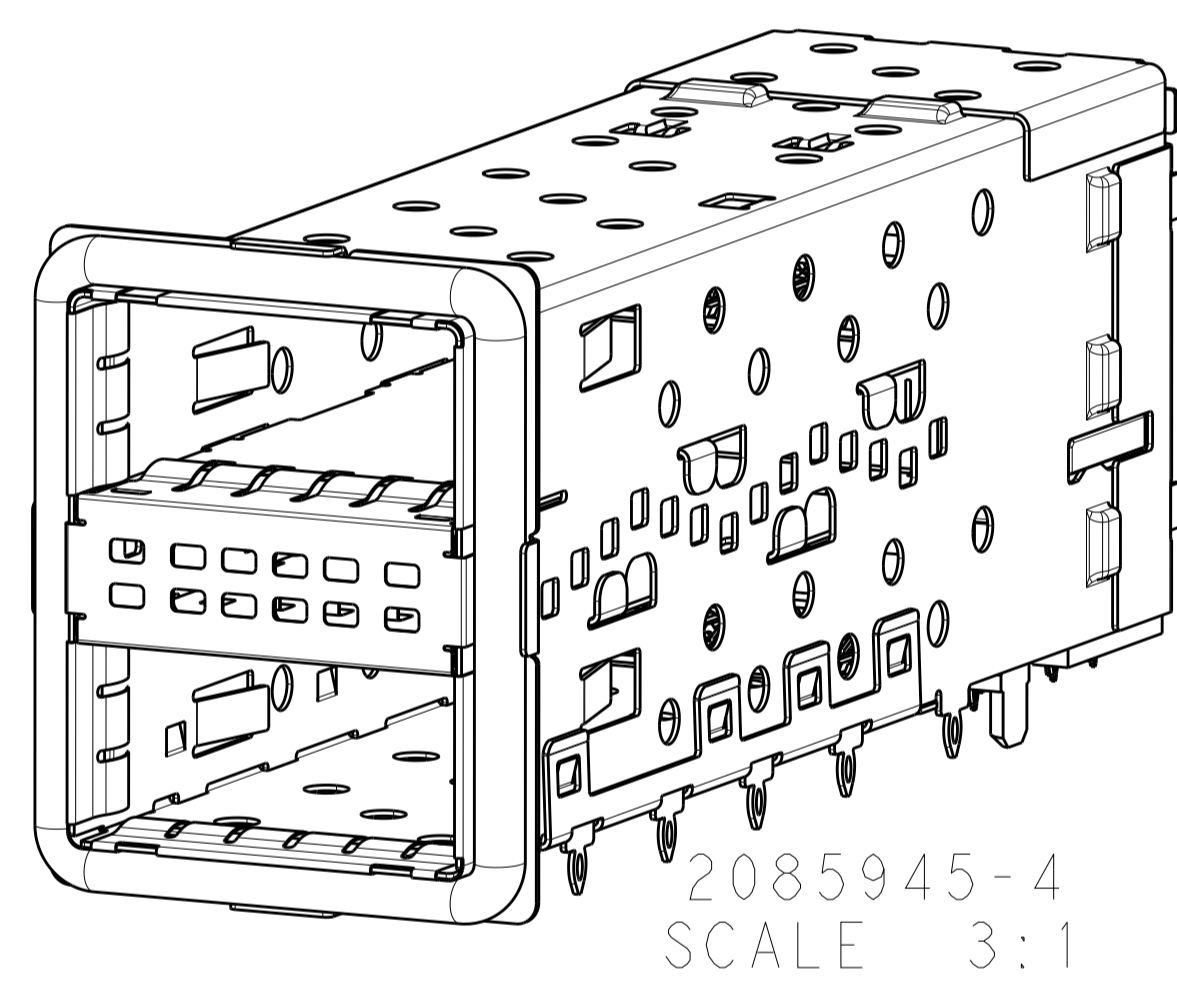
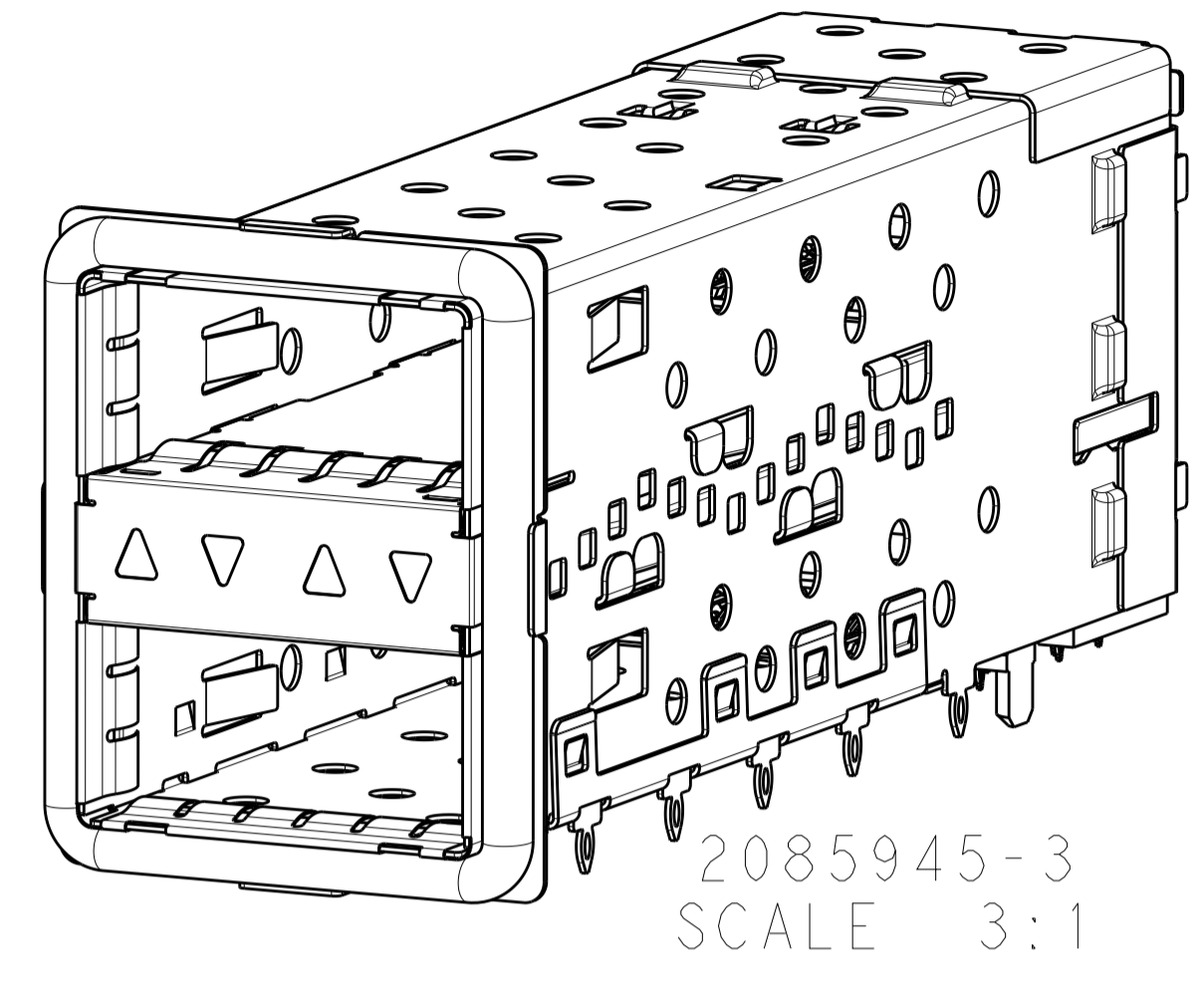
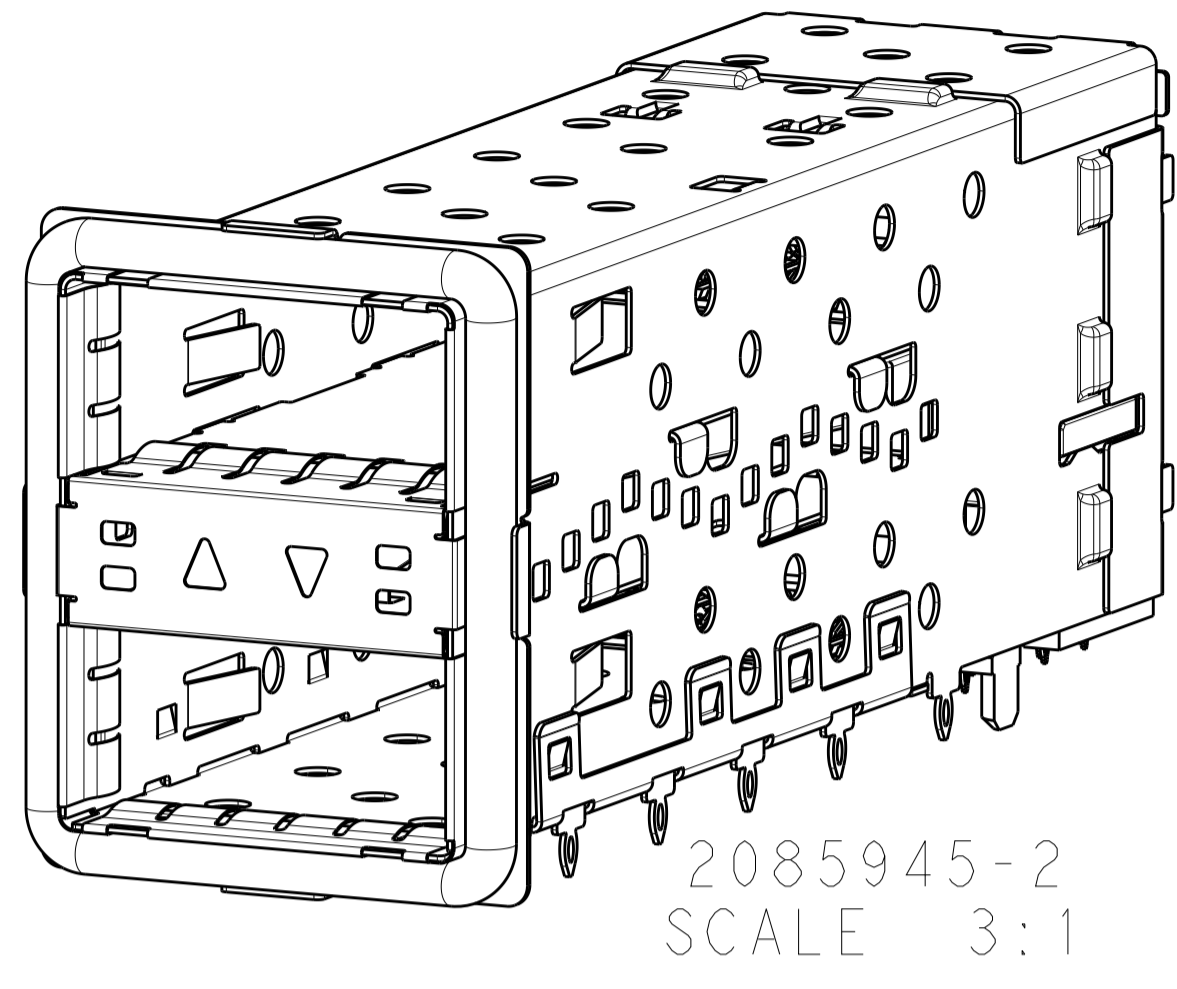
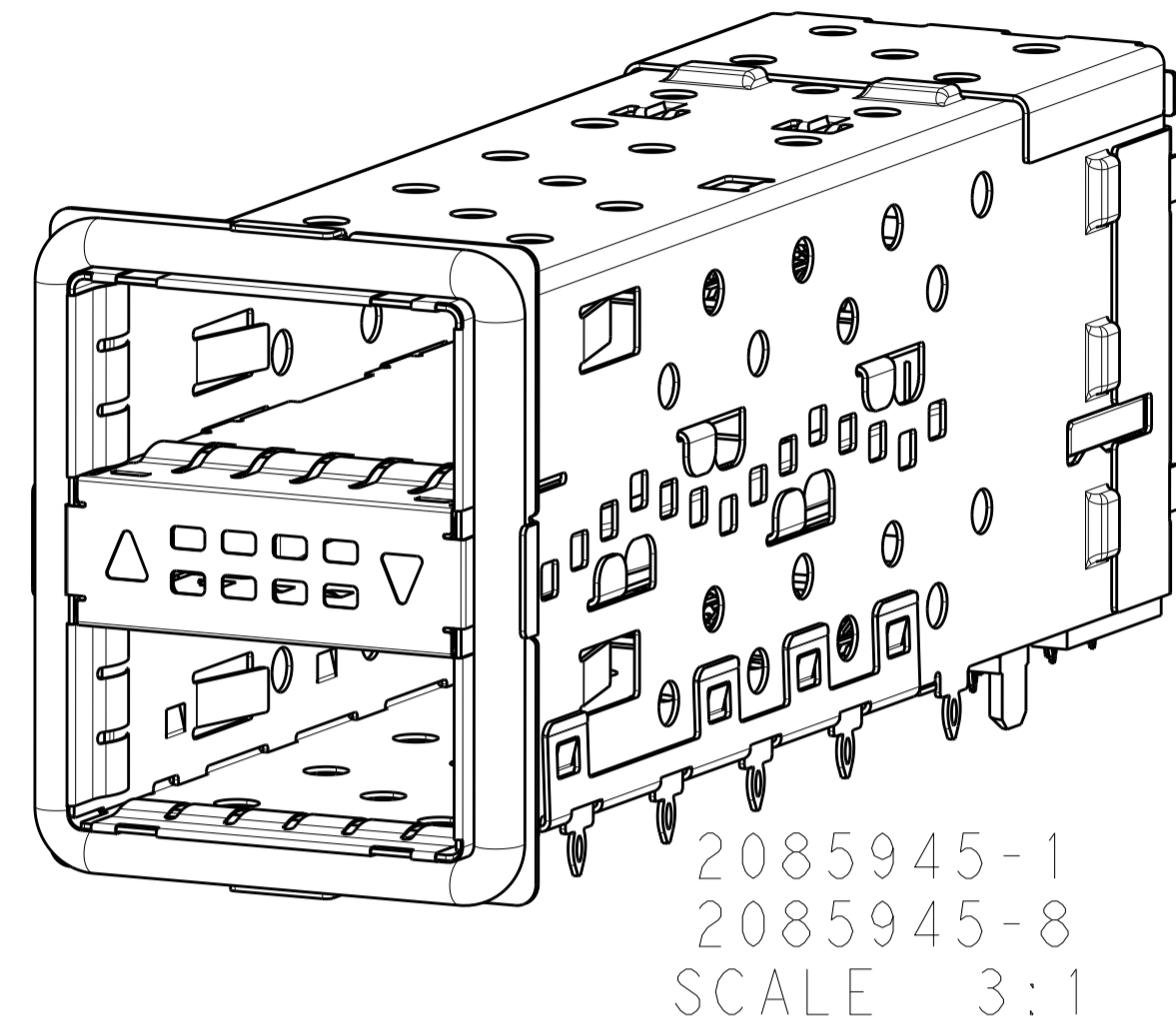

THIS DRAWING IS A CONTROLLED DOCUMENT.		OWN B. MCMASTER 08AUG11	TE Connectivity NAME CAGE AND PT CONNECTOR ASSEMBLY, WITH EMI GASKET, PRESS FIT, 2X1, STACKED QSFP+
DIMENSIONS:		CHK E. WICKES 08AUG11	
TOLERANCES UNLESS OTHERWISE SPECIFIED:		APVD E. WICKES 08AUG11	
mm		PRODUCT SPEC	
0 PLC	±	108-127010	SIZE
1 PLC	±0.30	APPLICATION SPEC	CAGE CODE
2 PLC	±0.25	114-32020	DRAWING NO
3 PLC	±	WEIGHT	RESTRICTED TO
4 PLC	±		A100779C=2085945
ANGLES	±		
MATERIAL	FINISH		
		CUSTOMER DRAWING	SCALE 4:1 SHEET 4 OF 4 REV 11