

SERPAC 1712AA (exploded isometric)

Electronic Enclosures

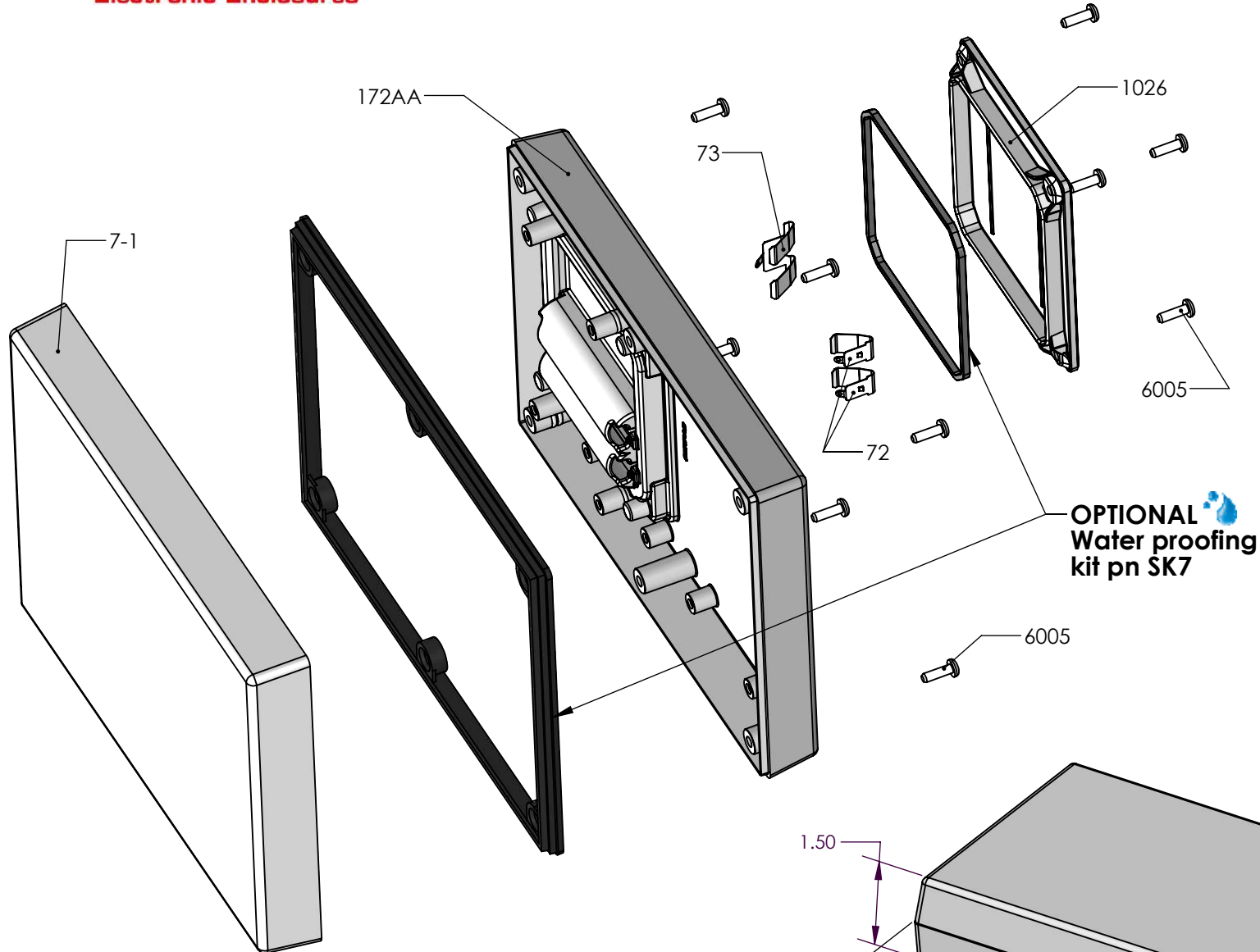

OPTIONAL
Water proofing
kit pn SK7

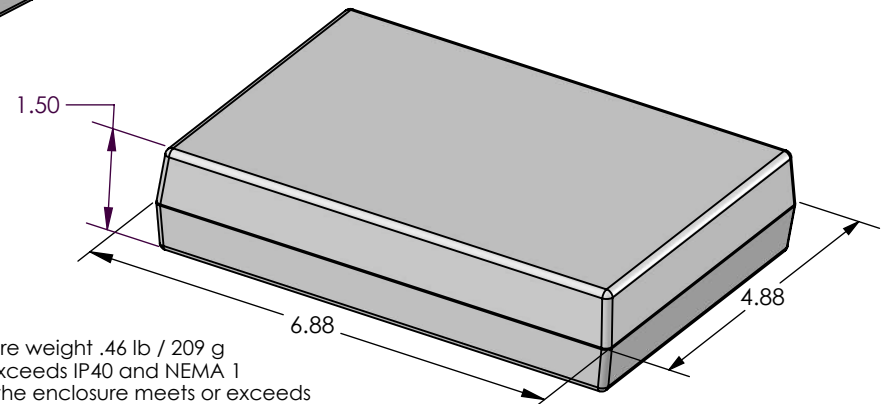

PART NO.	DESCRIPTION (Included)	ACCESSORIES (Optional)	
7-1	Top	PART NO.	DESCRIPTION
172AA	2AA Bottom	50	Non-skid Feet
1026	Access Door	SK7	Seal Kit for 17X
6005	#4X3/8" Self-Tapping Screw (10)		
72	Single Battery contact (2)		
73	Double Battery contact		

- Notes:
- 1) Enclosure meets or exceeds IP40 and NEMA 1
 - 2) When used with SK7 the enclosure meets or exceeds IP 67 and NEMA 4X, 12 and 13 MIL-STD-810G 506.5 (.03 lb / 14 g)
 - 3) Circuit Board drawings see sheet 3.
 - 4) All components are RoHS Compliant.

SERPAC 1712AA

Electronic Enclosures

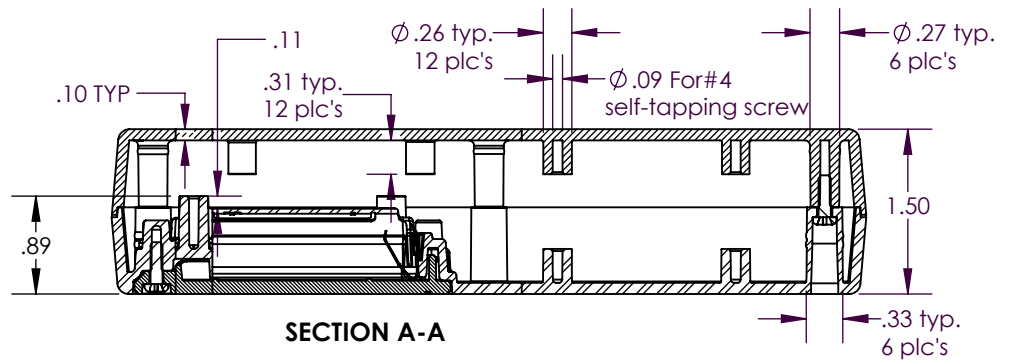
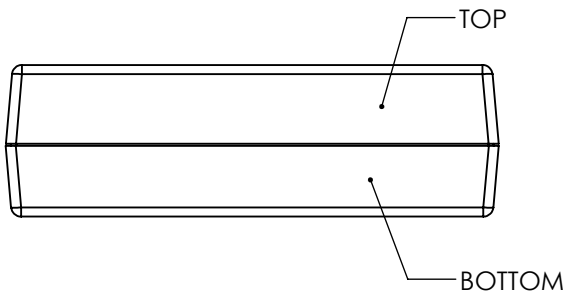
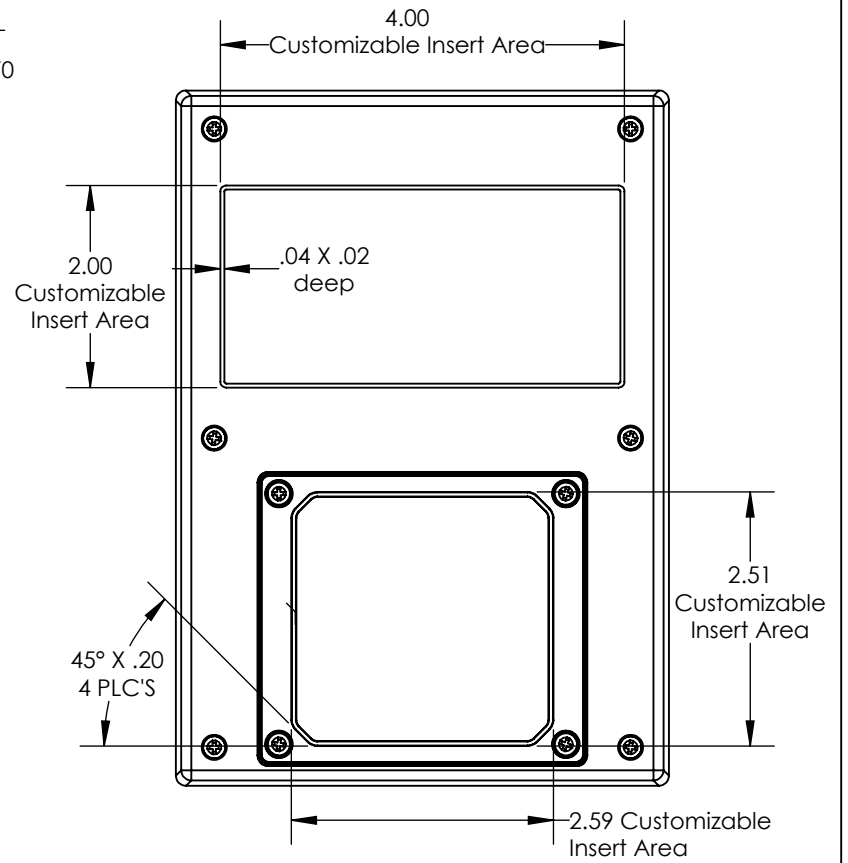
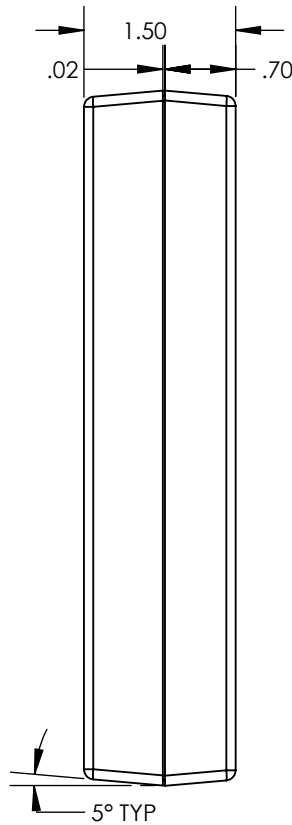
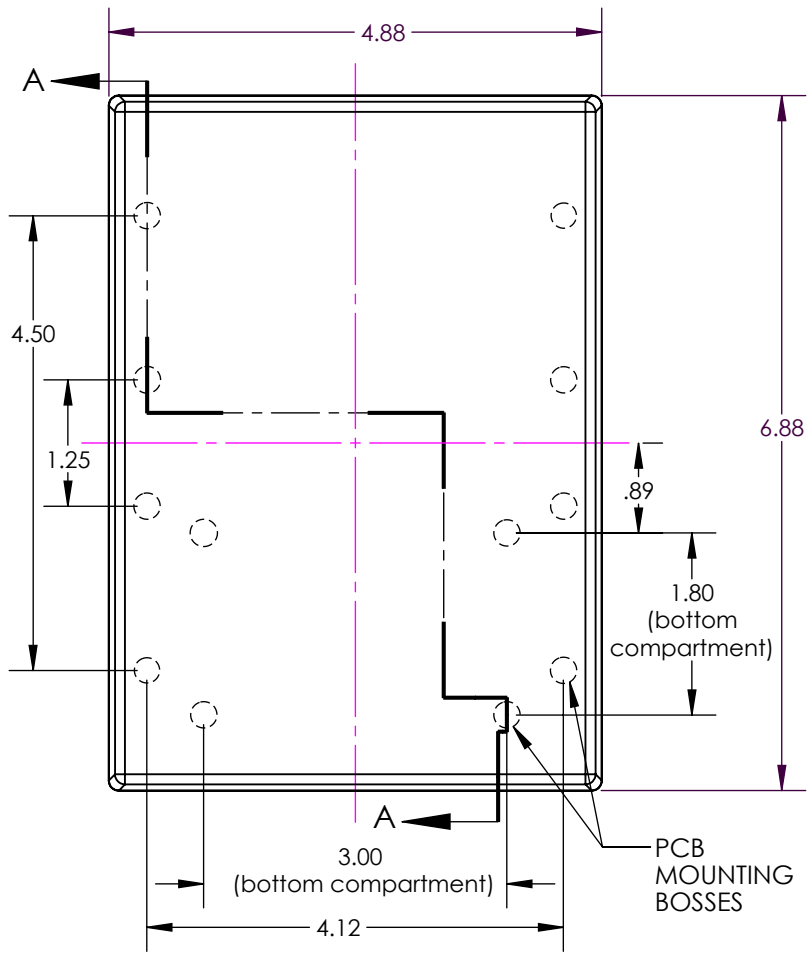

CIRCUIT BOARD FOR TOP

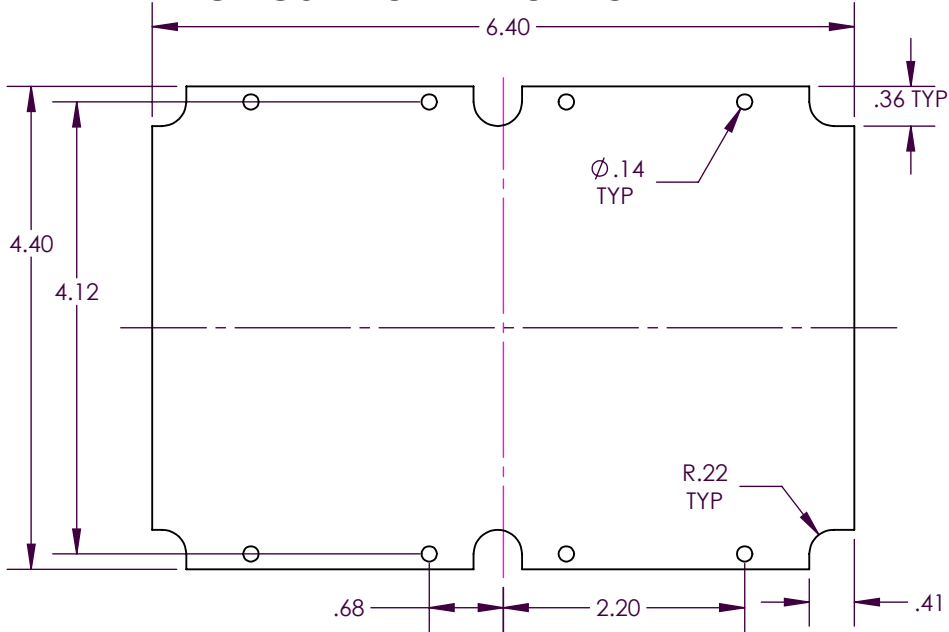

CIRCUIT BOARD FOR BOTTOM

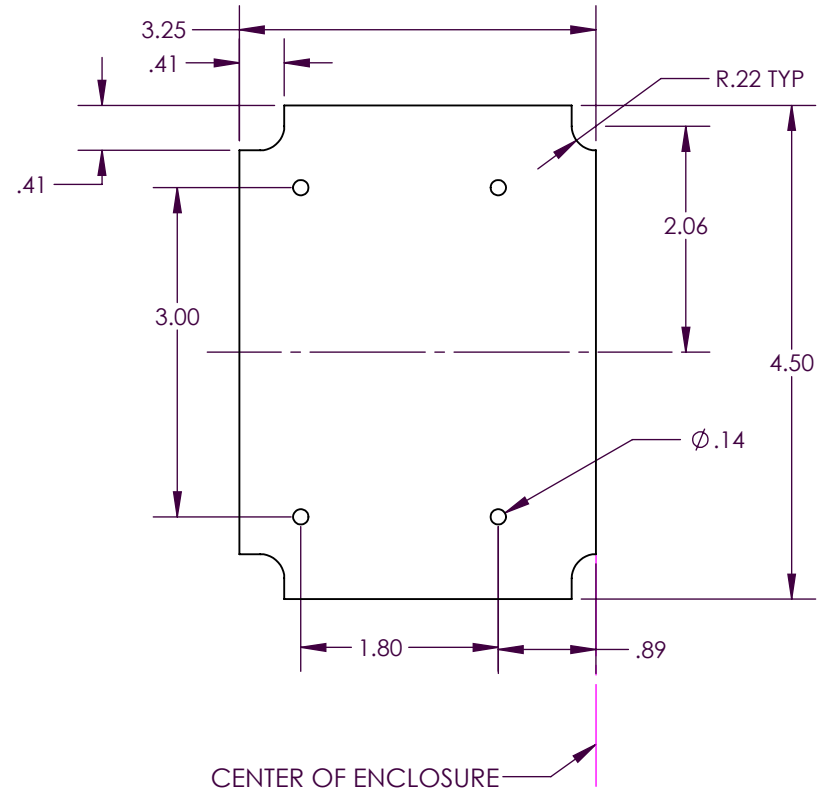

SMALL CIRCUIT BOARD FOR BOTTOM

