

T2200 3 Phase Overcurrent Relay

- Protection of generators against overcurrent
- Visual indication of power, pick-up and relay tripping
- High precision digital countdown timer for delayed output
- Accepts high supply voltage variations: 60 - 110%
- Cost effective and highly reliable compact design
- 50 hours burn-in before final test
- Operating temperature range: -20°C to +70°C
- Certified by major marine classification societies
- Flame retardant enclosure
- DIN rail or screw mounting

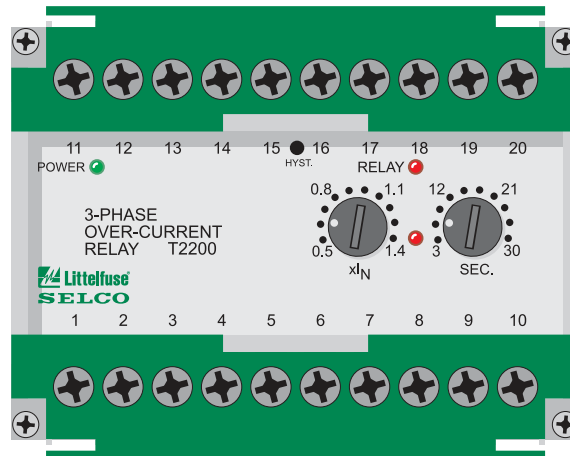

Application

The T2200 3 Phase Overcurrent Relay has a broad application where all 3 phases or any single phase current detection will function for protection, control and monitoring.

The T2200 is part of the SELCO T-Line series with modular units for protection, control and monitoring of generators, both in marine and land-based applications. The T2200 is type approved by major marine classification societies.

Function

The T2200 detects the highest of the 3 input currents and, if this exceeds the preset level ($0.5 - 1.4 \times I_N$), the pick-up LED will indicate and the delay timer will be started.

After the preset time (3 - 30 sec.) has expired, the output relay and the corresponding LED will be activated, provided that the current level was exceeded for the entire delay time.

The T2200 can be provided with an extra output relay. See connection diagram.

The T2200 can also be provided with a latching output relay. The latching can be reset or disabled by bridging terminals 5 and 6. On units with two output relays, reset is done by disconnecting the power supply.

Installation

The supply voltage is connected to terminals 1 and 3 or terminals 2 and 3, according to the supply source.

The T2200 is connected to the measuring current coming from the current transducers secondary via terminals 11-12, 13-14 and 15-16. See connection diagram.

The current setting can be calculated according to the following example:

Overcurrent protection of a generator.

Required trip level: 110%

Generator rating: 695A

Current transformer: 800/5A

Setting: $110 \times 695/800 = 96\% = 0.96 \times I_N$

Troubleshooting

- 1) If the relay is not operating please check that the power LED is on, ensuring that the supply is present.
- 2) Measure the supply voltage which must be compatible with the information label on top of the enclosure.
- 3) Measure the current levels in terminals 11-12, 13-14 and 15-16 and check that at least one of the currents is above setting.

For example:

$0.5 \times I_N = 2.5A$; $1 \times I_N = 5A$

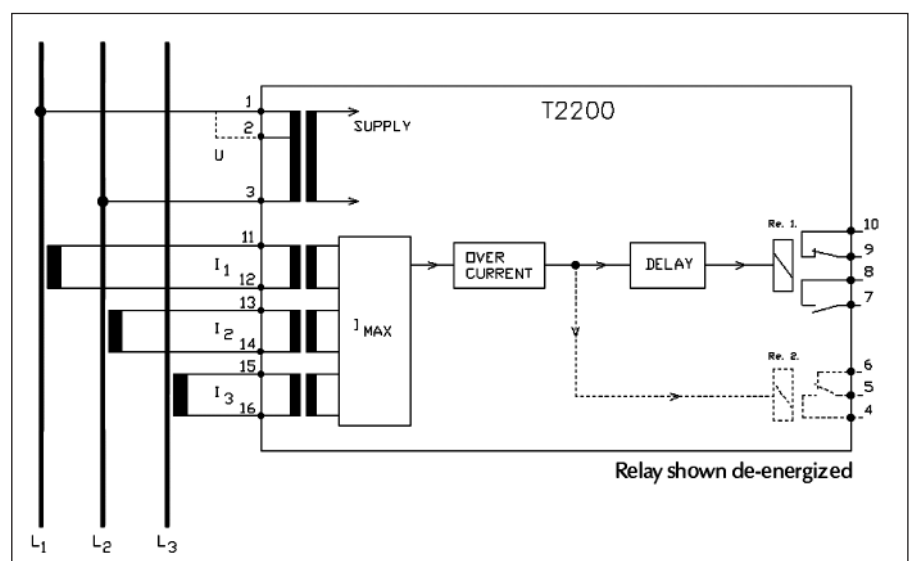

Connection diagram. The dotted lines illustrate connection possibilities on units with an extra output relay.

Specifications

T2200 3 Phase Overcurrent Relay

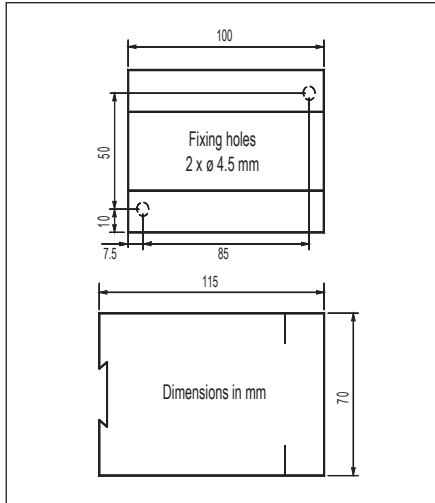

Dimensions.

Type Approvals and Certificates

The T2200 has been designed and tested for use in harsh environments. The unit is based on standard components, providing long term durability. The T2200 carries the CE label and has been approved by the following marine classification societies:



Bureau Veritas
Croatian Register of Shipping
Germanischer Lloyd
Polish Register of Shipping
Romanian Register of Shipping
Russian Maritime Register of Shipping

Trip level	0.5 - 1.4 x I _N
Delay	3 - 30 sec.
Max. voltage	660V
Voltage range	60 - 110%
Consumption	Voltage 5VA at U _N Current 0.3VA at I _N
Continuous current	2 x I _N
Frequency range	45 - 400Hz
Output relay	Normally de-energized
Contact rating	AC: 400V, 5A, 2000VA DC: 150V, 5A, 150W
Overall accuracy	±5%
Repeatability	±1%
Operating temperature	-20°C to +70°C
Dielectric test	2500V, 50Hz
EMC	CE according to EN50081-1, EN50082-1, EN50081-2, EN50082-2
Approvals	Certified by major marine classification societies
Burn-in	50 hours before final test
Enclosure material	Polycarbonate. Flame retardant
Weight	0.5kg
Dimensions	70 x 100 x 115mm (H x W x D)
Installation	35mm DIN rail or 4mm (3/16") screws

The specifications are subject to change without notice.

Type Selection Table

Standard types: I_N = 5A.

Type	Terminals		I _N	Function
	1-3	2-3		
T2200.0010	450V	400V	5A	Latching output, resetable
T2200.0020	450V	400V	5A	Normally energized output, latching, resetable
T2200.0030	230V		5A	Latching output, resetable
T2200.0040	230V	110V	5A	Latching output, resetable
T2200.0050	230V		1A	Latching output, resetable
T2200.0060	450V	400V	5A	Normally energized output, latching, resetable, delay 6 - 60 sec.
T2200.0070	110V	100V	5A	Latching output, resetable
T2200.0080	480V	415V	5A	Latching output, resetable
T2200.0090	24V DC		5A	Latching output, resetable
T2200.0100	450V	400V	5A	Instantly extra output relay
T2200.0110	450V	400V	1A	Instantly extra output relay

Other supply voltages and combinations are available on request.

Main office:
Betonvej 10
DK-4000 Roskilde
Denmark
Phone: + 45 7026 1122
Fax: + 45 7026 2522
e-mail: selco.dk@selco.com
www.selco.com

