

# TPS2456EVM

The TPS2456EVM is an evaluation module used to evaluate the TPS2456 Dual 12V Protection/Blocking Controller. The TPS2456 provides hot swap capability and diode Or functions via external Mosfets. The board is configured with the following nominal specifications.

Fast Trip Current Limit:	20A each channel
Current Limit:	8.36A each channel or 16.72A total
Length of Fault Timer:	2.97ms
Time between retries	800ms
Selectable On-Board Output Capacitance	220 $\mu$ F, 440 $\mu$ F, 660 $\mu$ F or 880 $\mu$ F
Selectable On-Board Bleed Resistance	1k $\Omega$

## 1 EVM Layout

The overall layout of the TPS2456EVM is shown in [Figure 1](#). Channel A is the upper portion of the board and Channel B is the midsection. The lower portion of the board contains the optional automatic retry on fault circuitry.

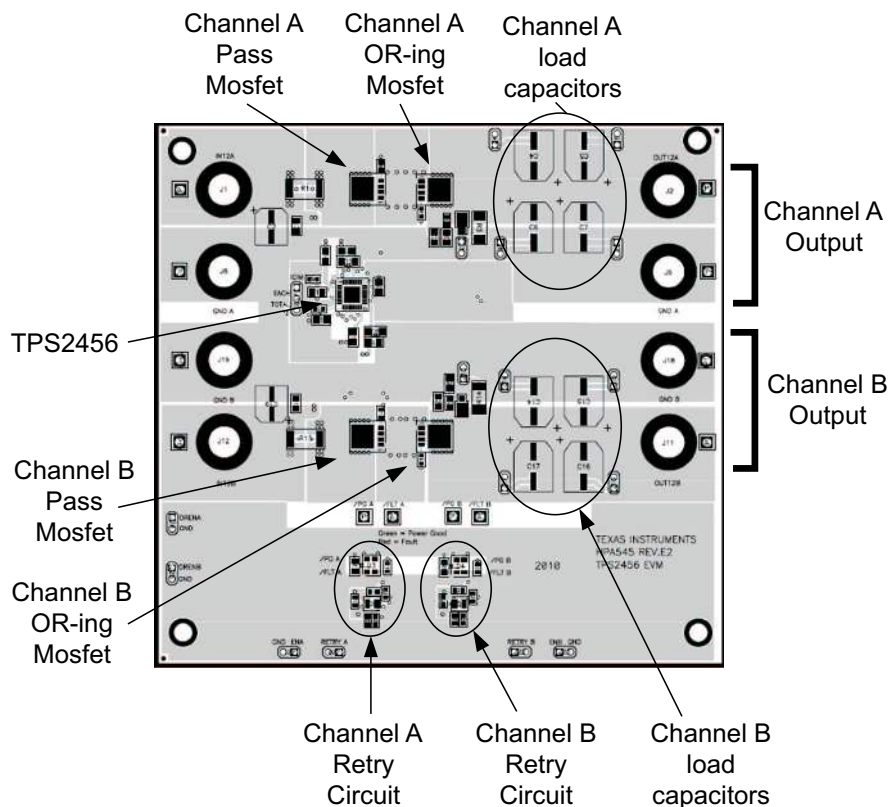

**Figure 1. TPS2456 General Layout**

## 2 Connector and Jumper Description

J1	Channel A positive input supply voltage
J2	Channel A hot swap positive output voltage
J3	Shorting this jumper connects a 1k $\Omega$ resistor across the output of Channel A. This is useful to discharge any output capacitance on Channel A.
J4–J7	Channel A Load Capacitors. Shorting each of these jumpers will add 220 $\mu$ F of capacitance across the output of the board. A total of 880 $\mu$ F can be placed across the output using these four jumpers.
J8	Channel A input supply voltage return (ground).
J9	Channel A output voltage return (ground)
J10	Current limit selection. Jumping pin 1 to pin 2 (EACH) sets the current limit of each channel to 8.36A. This could provide a total of 16.72A of current to the load if there is equal current sharing between the two channels. Jumping pin 2 to pin 3 (TOTAL) sets the total maximum current provided to the load to 8.36A.
J11	Channel B hot swap positive output voltage
J12	Channel B positive input supply voltage
J13	Shorting this jumper connects a 1k $\Omega$ resistor across the output of Channel B. This is useful to discharge any output capacitance on Channel B.
J14–J17	Channel B Load Capacitors. Shorting each of these jumpers will add 220 $\mu$ F of capacitance across the output of the board. A total of 880 $\mu$ F can be placed across the output using these four jumpers
J18	Channel B output voltage return (ground)
J19	Channel B input supply voltage return (ground).
J20	Retry A: Shorting this jumper enables a channel retry function where the TPS2456 will attempt to repower a Channel A after a fault has occurred. The TPS2456 will continuously retry until the fault is removed. If the jumper is left open then the channel will be latched off when a fault occurs.
J21	ENA: Shorting this jumper connects pin 31 (ENA) of the TPS2456 to ground thus disabling Channel A of the TPS2456.
J22	Retry B: Shorting this jumper enables a channel retry function where the TPS2456 will attempt to repower a Channel B after a fault has occurred. The TPS2456 will continuously retry until the fault is removed. If the jumper is left open then the channel will be latched off when a fault occurs.
J23	ENB: Shorting this jumper connects pin 29 (ENB) of the TPS2456 to ground thus disabling Channel B of the TPS2456.
J24	ORENA: Shorting this jumper connects pin 6 (ORENA) of the TPS2456 to ground thus disabling the OR-ing function. The board has a OR-ing transistor (Q2) installed in series with the power path. Under normal conditions, this jumper should be left open to enable the OR-ing transistor so current can flow to the output.
J25	ORENB: Shorting this jumper connects pin 14 (ORENB) of the TPS2456 to ground thus disabling the OR-ing function. The board has a OR-ing transistor (Q4) installed in series with the power path. Under normal conditions, this jumper should be left open to enable the OR-ing transistor so current can flow to the output.

### 3 Setup

#### 3.1 Basic Setup

Figure 1 shows the basic setup for performance bench testing using resistive loads on channel A. Channel B can be configured the same way as well if dual channel testing is desired. In this set-up, the on board capacitors (C4–C7) can be used to supply a capacitive load to check the output voltage ramp. A load can be connected to the output of the TPS2456EVM as shown.

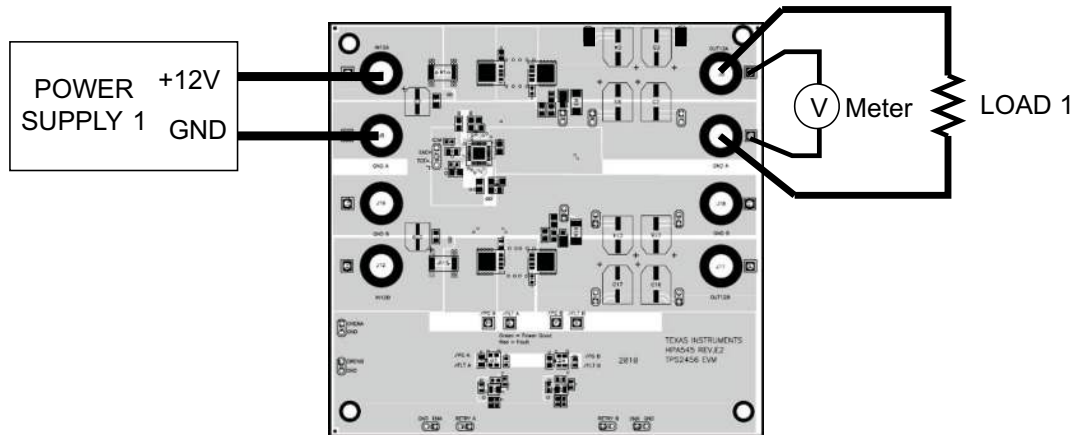

During the output voltage ramp-up, the current drawn from the input power supply is equal to the current in the resistor plus the current required to charge the capacitance. The total current available for the resistor and capacitors is fixed by the current limit of the TPS2456 which is set to a nominal 8.36A on the EVM board. The 8.36A of available current must charge the capacitor and resistor combination up to 12V before the fault timer expires. The fault timer is set to a nominal 2.97ms on the EVM board. This means there is a minimum resistance value (maximum current draw) for the load for each selected output capacitance value. Any lower resistance draws too much current and triggers the fault timer. The minimum resistance value, based on nominal or typical circuit values, that can be supported is:

Output Capacitance	Load Resistance
220 $\mu\text{F}$	>1.43 $\Omega$
440 $\mu\text{F}$	>1.46 $\Omega$
660 $\mu\text{F}$	>1.56 $\Omega$
880 $\mu\text{F}$	>1.78 $\Omega$

Each channel of the TPS2456EVM can be independently enabled. Each channel can also be configured to latch-off during a fault or to periodically retry starting. The retry and enable functions are configured using shunts on two pin jumper headers. The functionality of these jumpers is:

J21	J20	Function
OPEN	OPEN	Channel A Enabled, Latch off on fault
OPEN	SHORT	Channel A Enabled, Retry on fault
SHORT	OPEN	Channel A Disabled
SHORT	SHORT	Channel A Disabled

J23	J22	Function
OPEN	OPEN	Channel B Enabled, Latch off on fault
OPEN	SHORT	Channel B Enabled, Retry on fault
SHORT	OPEN	Channel B Disabled
SHORT	SHORT	Channel B Disabled

### 3.2 Alternate Configurations

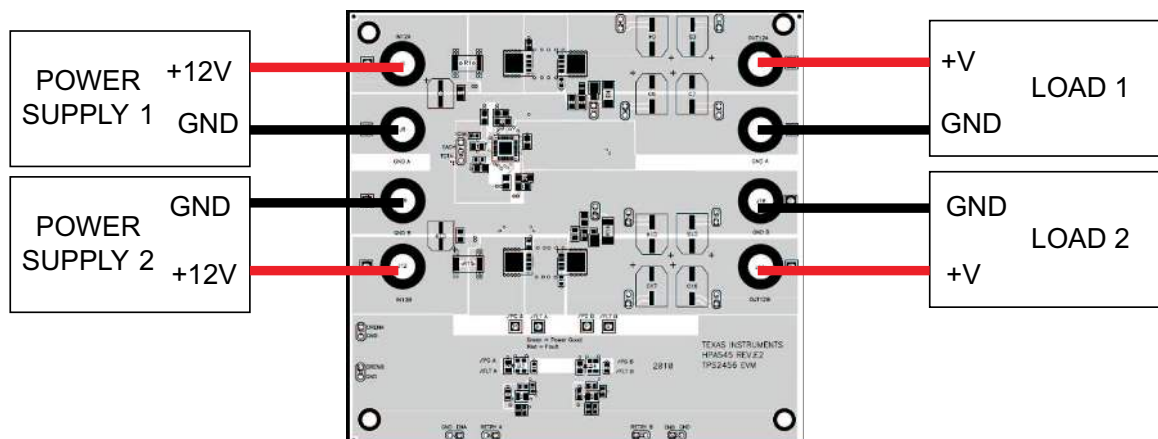
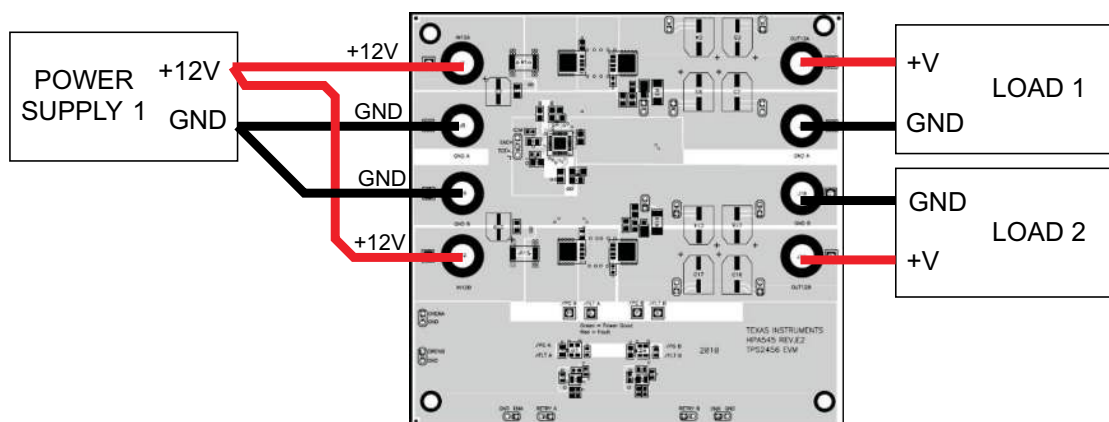

**Figure 2. Dual Channel**

#### **Jumper Configurations:**

J20 and J22 Jump to enable the retry on fault option for each respective channel. Leave open to latch channel off on fault.

J24 and J25: leave open to enable the OR-ing transistors. The OR-ing transistors are not required for this application, but are installed on the board; and therefore, must be enabled. J10 jump pin 1 to pin 2 (Each). Each channel has individual peak current limit.



**Figure 3. Two Protected Loads**

#### **Jumper configurations:**

J20 and J22 Jump to enable the retry on fault option for each respective channel. Leave open to latch channel off on fault.

J24 and J25: leave open to enable the OR-ing transistors. The OR-ing transistors are not required for this application, but are installed on the board; and therefore, must be enabled.

J10 jump pin 1 to pin 2 (Each). Each channel has individual peak current limit which protects the loads from overcurrent. The input supply must be capable of providing current equal to 2 times the current limit of a single channel. If the input power source rather than the loads needs to be protected from overcurrent then jump pin 2 to pin 3 on J10 (Total). The total current draw from the input power supply is limited to the peak current limit.

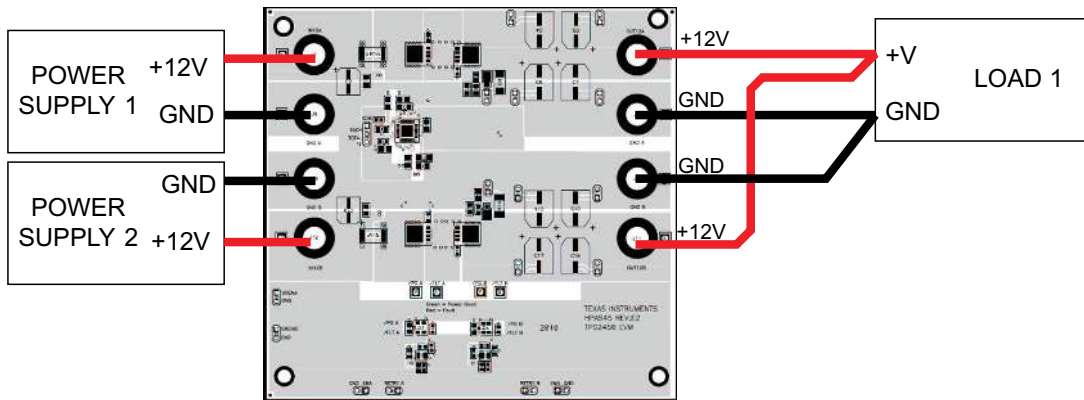

**Figure 4. Redundant Power Supply**

***Jumper Configurations:***

J20 and J22 Jump to enable the retry on fault option for each respective channel. Leave open to latch channel off on fault.

J24 and J25: leave open to enable the OR-ing transistors. The OR-ing transistors must be used in this configuration to prevent cross current conduction between input power sources.

J10 jump pin 1 to pin 2 (Each). Each channel has individual peak current limit which protects the input supplies from overcurrent conditions. The load can draw up to 2 times the current limit of a single channel in this configuration. If the load rather than the input power source needs to be protected from overcurrent then jump pin 2 to pin 3 on J10 (Total). The total current draw from the input power supply flowing to the load is limited to the peak current limit. Note the OR-ing fets act as diodes so current sharing is not ensured.

## 4 Schematic, PCB Layout and Bill of Materials

### 4.1 Schematic

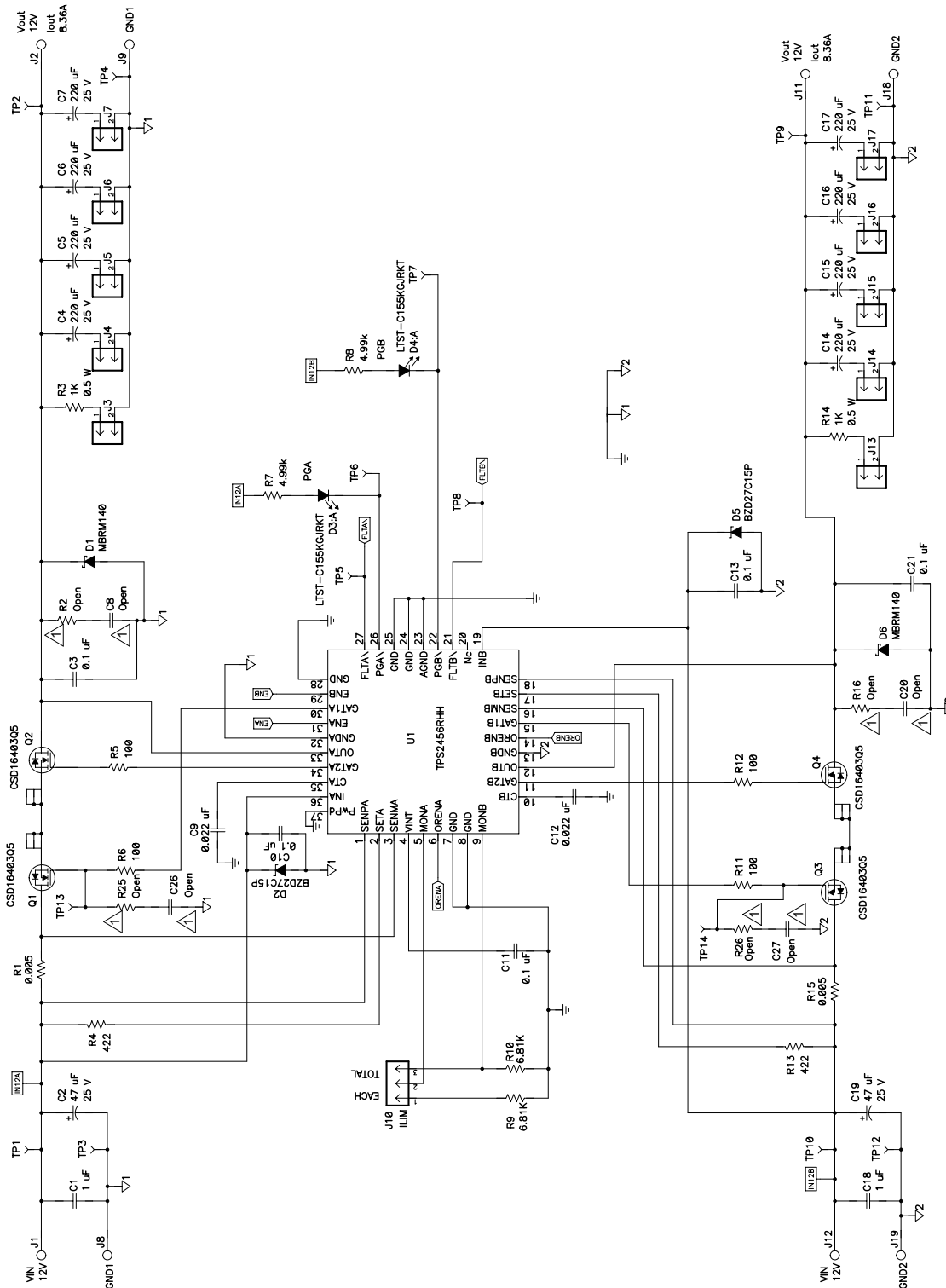

△ NOT INSTALLED.

Figure 5. TPS2456 Schematic

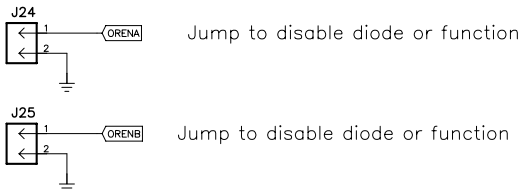
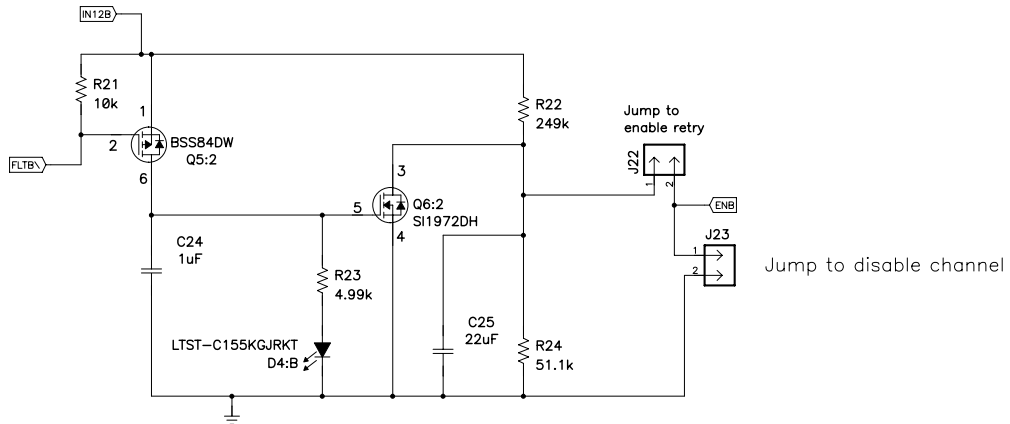
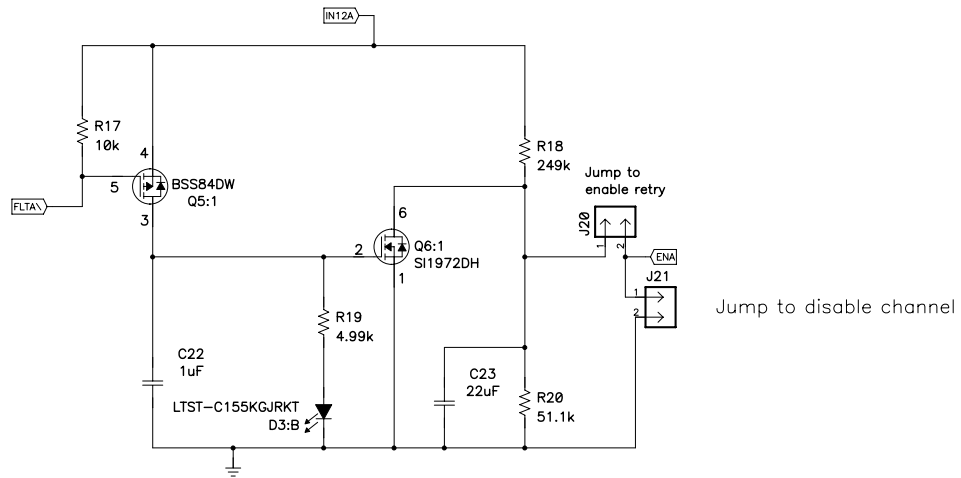

Figure 6. TPS2456 Schematic

## 4.2 PCB Layout

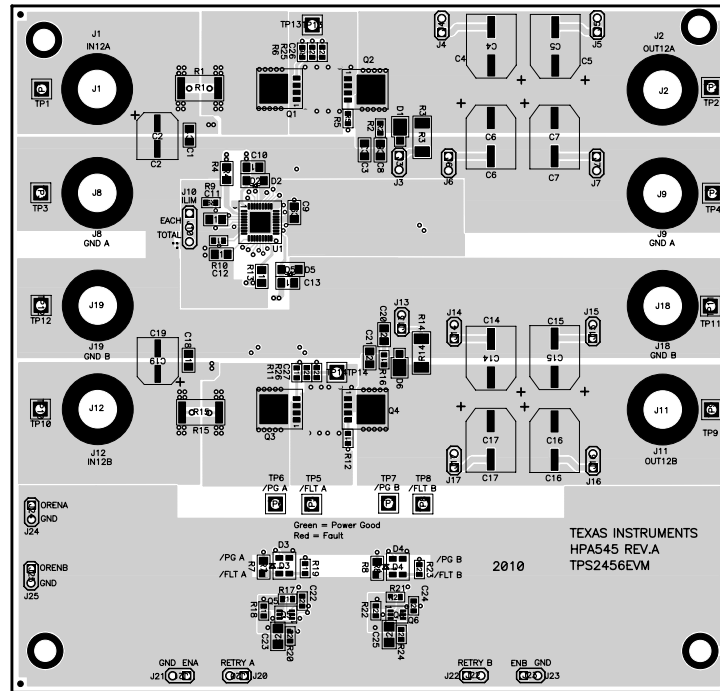

Figure 7. TPS2456 Top Layer Assembly

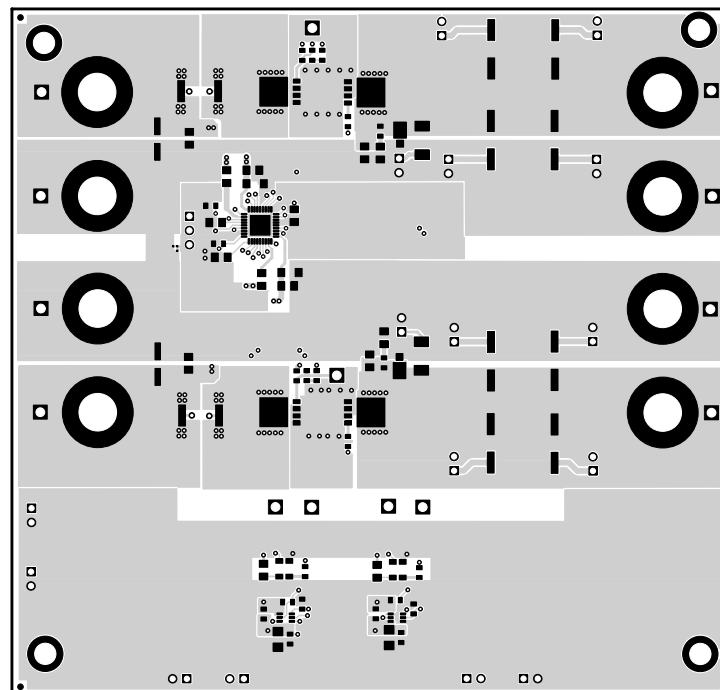
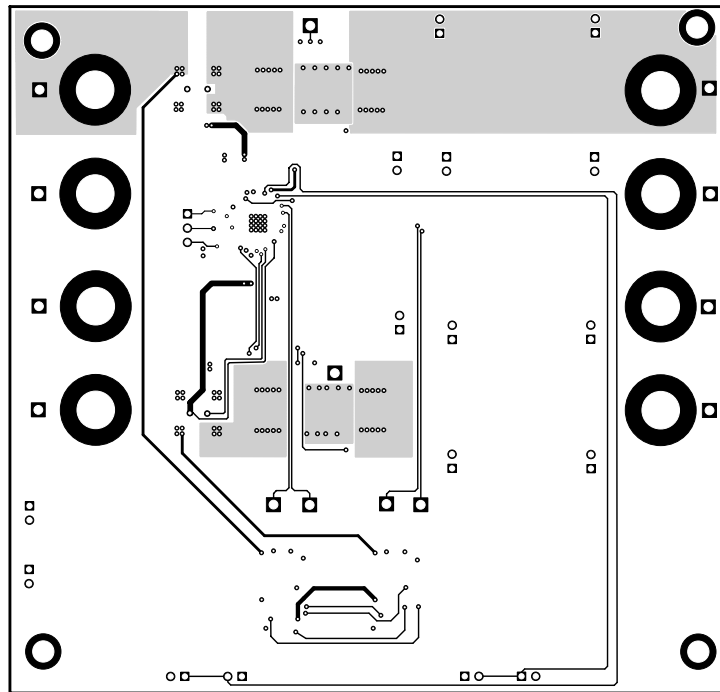
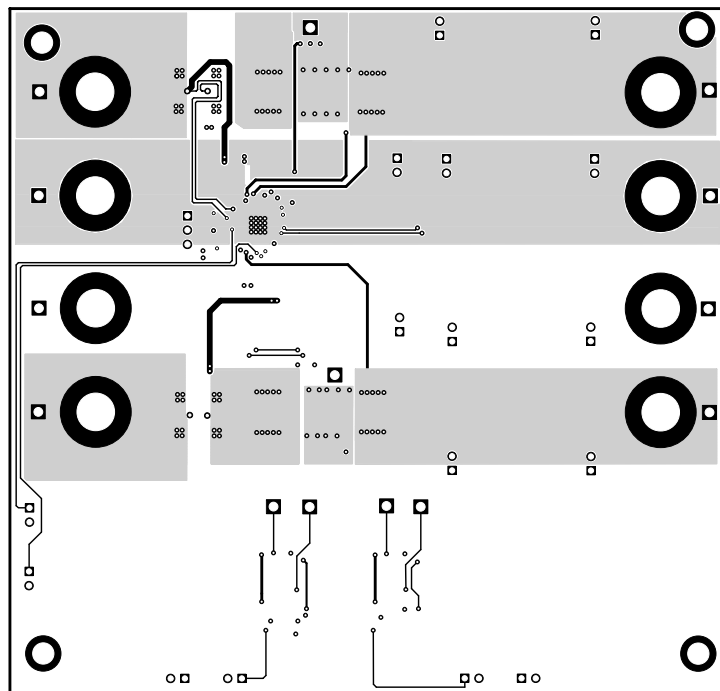

Figure 8. TPS2456 Top Layer Routing





**Figure 9. TPS2456 Layer 2 Routing**



**Figure 10. TPS2456 Layer 3 Routing**

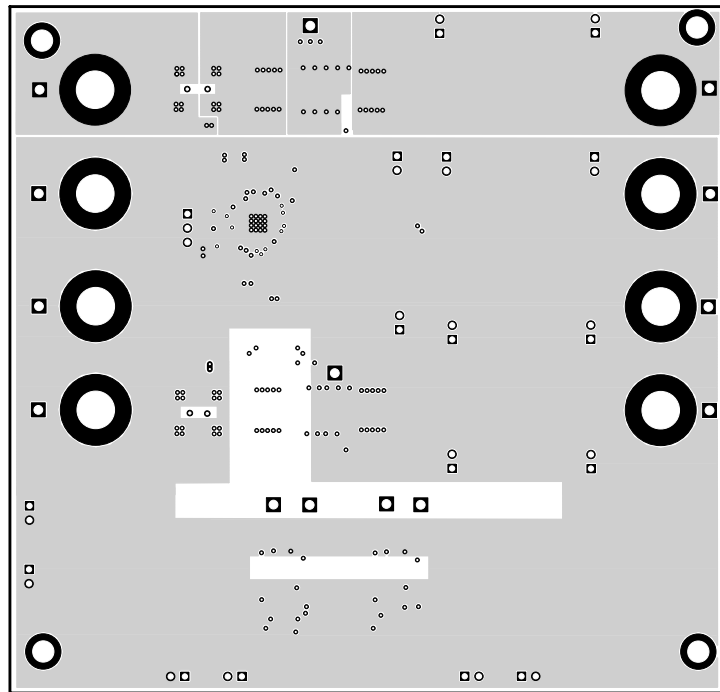

Figure 11. TPS2456 Layer 4 Routing

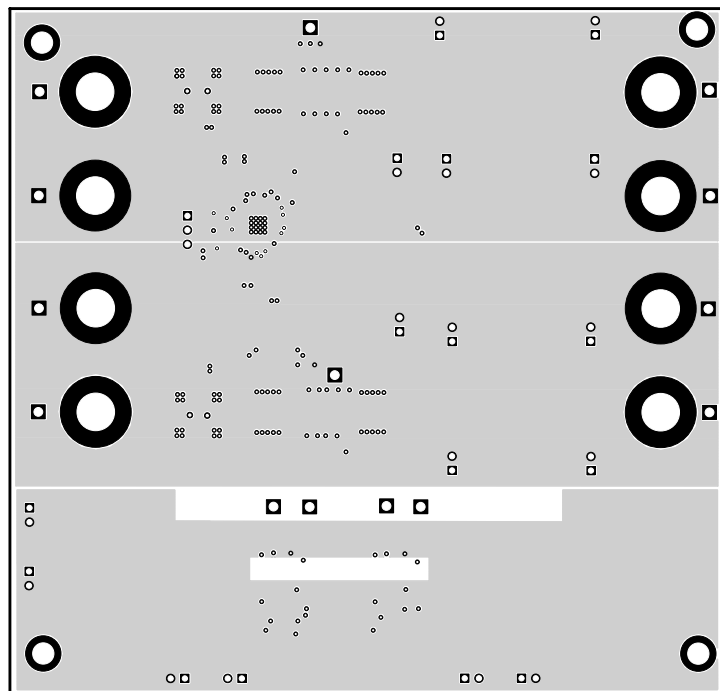
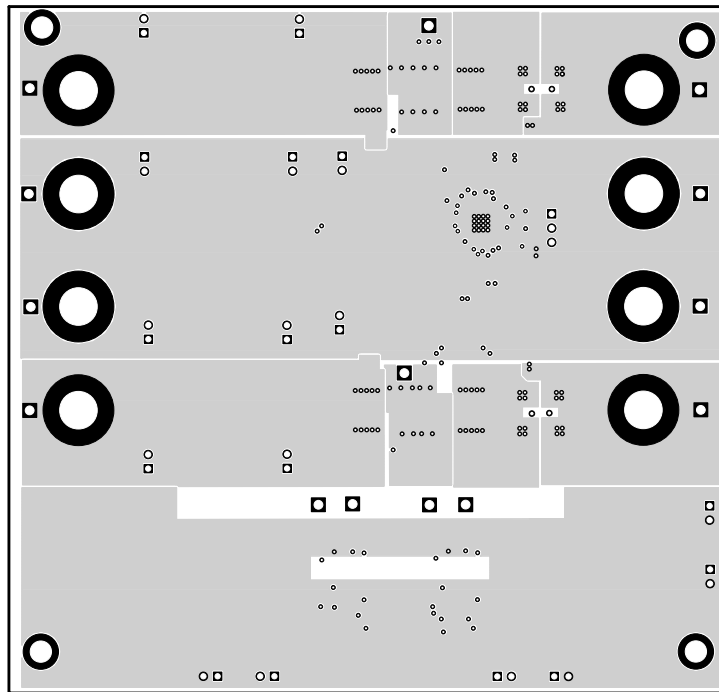

Figure 12. TPS2456 Layer 5 Routing



**Figure 13. TPS2456 Bottom Layer Routing**

### 4.3 Bill of Materials

**Table 1. TPS2456 BOM**

COUNT	RefDes	Value	Description	Size	Part Number	Mfr
2	C1, C18	1 uF	Capacitor, Ceramic, 25V, X7R, 20%	0805	Std.	Std.
2	C2, C19	47 uF	Capacitor, Aluminum, SM, 25V, ±20%	Case D	EEE-FK1E470P	Panasonic
2	C22, C24	1uF	Capacitor, Ceramic, 16V, X5R, 10%	0603	Std.	muRata
2	C23, C25	22uF	Capacitor, Ceramic, 16V, X5R, 10%	1206	Std.	muRata
0	C26, C27	Open	Capacitor, Ceramic, 25V	0603	Std.	muRata
5	C3, C10, C11, C13, C21	0.1 uF	Capacitor, Ceramic, 25V, X7R, 20%	0805	Std.	Std.
8	C4, C5, C6, C7, C14, C15, C16, C17	220 uF	Capacitor, Aluminum, SM, 25V, ±20%	Case F	EEE-FK1E221P	Panasonic
0	C8, C20	Open	Capacitor, Ceramic, 25V, X7R, 20%	0805	Std.	Std.
2	C9, C12	0.022 uF	Capacitor, Ceramic, 10V, X7R, 10%	0805	Std.	Std.
2	D1, D6	MBRM140	Diode, Schottky, 1A, 40V	457-04	MBRM140G	On Semi
2	D2, D5	BZD27C15P	"Diode, Zener, 15 V @ 50 mA, .800 mW max., Pzsm = 300 W"	D0-219AB	BZD27C15P	Vishay
2	D3, D4	LTST-C155KGJRKT	Diode, Dual LED, Water Clear, 80-mA, 35/25-mcd	0.126 X 0.106 inch	LTST-C155KGJRKT	Lite On
8	J1, J2, J8, J9, J11, J12, J18, J19		Jack, Banana, Non-ins., PC Mount	TH	3267	Pomona
1	J10	PEC03SAAN	Header, Male 3-pin, 100mil spacing,	0.100 inch x 3	PEC03SAAN	Sullins
16	J3, J4, J5, J6, J7, J13, J14, J15, J16, J17, J20, J21, J22, J23, J24, J25	PEC02SAAN	Header, 2-pin, 100-mil spacing	0.100 in. x 2	PEC02SAAN	Sullins
4	Q1, Q2, Q3, Q4	CSD16403Q5	MOSFET, NChan, 25V, 28A, 2.9 milliOhm	QFN5X6mm	CSD16403Q5	TI
1	Q5	BSS84DW	MOSFET, Dual Pch, 50V, 130 mA	SC-70	BSS84DW-7-F	Diodes
1	Q6	SI1972DH	MOSFET, Dual Nch, 30V, 1.3A, 190 milliOhms,	SC-70	SI1972DH-TI-E3	Vishay
2	R1, R15	0.005	Resistor, Metal Strip, 1 W, 1%	2512	WSL2512-5L000FEA	Vishay-Dale
2	R17, R21	10k	Resistor, Chip, 1/16W, 1%	0603	Std.	Vishay
2	R18, R22	249k	Resistor, Chip, 1/16W, 1%	0603	Std.	Vishay
2	R19, R23	4.99k	Resistor, Chip, 1/16W, 1%	0603	Std.	Vishay
0	R2, R16, R25, R26	Open	Resistor, Chip, 1/16W, 1%	0603	Std.	Vishay
2	R20, R24	51.1k	Resistor, Chip, 1/16W, 1%	0603	Std.	Vishay
2	R3, R14	1K	Resistor, Chip, 1/2 W, 5%	2010	Std.	Std.
2	R4, R13	422	Resistor, Chip, 1/10 W, 1%	0805	Std.	Std.
4	R5, R6, R11, R12	100	Resistor, Chip, 1/16W, 1%	0603	Std.	Vishay
2	R7, R8	4.99k	Resistor, Chip, 1/10 W, 5%	0805	Std.	Std.
2	R9, R10	6.81K	Resistor, Chip, 1/16W, 1%	0603	Std.	Vishay
10	TP1, TP2, TP5, TP6, TP7, TP8, TP9, TP10, TP13, TP14	5012	Test Point, White, 0.062 in. Hole	TH	5012	Keystone
4	TP3, TP4, TP11, TP12	5011	Test Point, Black, 0.062 in. Hole	TH	5011	Keystone
1	U1	TPS2456RHH	IC, Dual 12 V Hot Swap / ORing Controller	QFN-36	TPS2456RHH	TI
1	N/A		PCB, FR-4, 6-Layer, SMOBC, 4.830" x 5.070" x .062"		HPA545**	Any
15	N/A		Shunt, Open-top		151-8000	Kobiconn
4	N/A		SPACER, Nylon, Hex, #6-32, 0.625"		14HTSP020	Eagle
4	N/A		SCREW, Nylon, Rnd Hd, #6-32, 0.25"		010632R025	Eagle

Notes: 1. These assemblies must be clean and free from flux and all contaminants. Use of no clean flux is not acceptable.  
2. These assemblies must comply with workmanship standards IPC-A-610 Class 2.  
3. Ref designators marked with an asterisk (\*\*\*) cannot be substituted. All other components can be substituted with equivalent MFG's components.  
4. If banana jacks (J1 - J2), (J8 - J9), (J11 - J12) and (J18 - J19) are supplied with solder lugs, dispose of lugs prior to installation on PCB. Solder lugs are NOT to be installed on assembly.

## Evaluation Board/Kit Important Notice

Texas Instruments (TI) provides the enclosed product(s) under the following conditions:

This evaluation board/kit is intended for use for **ENGINEERING DEVELOPMENT, DEMONSTRATION, OR EVALUATION PURPOSES ONLY** and is not considered by TI to be a finished end-product fit for general consumer use. Persons handling the product(s) must have electronics training and observe good engineering practice standards. As such, the goods being provided are not intended to be complete in terms of required design-, marketing-, and/or manufacturing-related protective considerations, including product safety and environmental measures typically found in end products that incorporate such semiconductor components or circuit boards. This evaluation board/kit does not fall within the scope of the European Union directives regarding electromagnetic compatibility, restricted substances (RoHS), recycling (WEEE), FCC, CE or UL, and therefore may not meet the technical requirements of these directives or other related directives.

Should this evaluation board/kit not meet the specifications indicated in the User's Guide, the board/kit may be returned within 30 days from the date of delivery for a full refund. **THE FOREGOING WARRANTY IS THE EXCLUSIVE WARRANTY MADE BY SELLER TO BUYER AND IS IN LIEU OF ALL OTHER WARRANTIES, EXPRESSED, IMPLIED, OR STATUTORY, INCLUDING ANY WARRANTY OF MERCHANTABILITY OR FITNESS FOR ANY PARTICULAR PURPOSE.**

The user assumes all responsibility and liability for proper and safe handling of the goods. Further, the user indemnifies TI from all claims arising from the handling or use of the goods. Due to the open construction of the product, it is the user's responsibility to take any and all appropriate precautions with regard to electrostatic discharge.

**EXCEPT TO THE EXTENT OF THE INDEMNITY SET FORTH ABOVE, NEITHER PARTY SHALL BE LIABLE TO THE OTHER FOR ANY INDIRECT, SPECIAL, INCIDENTAL, OR CONSEQUENTIAL DAMAGES.**

TI currently deals with a variety of customers for products, and therefore our arrangement with the user **is not exclusive.**

TI assumes **no liability for applications assistance, customer product design, software performance, or infringement of patents or services described herein.**

Please read the User's Guide and, specifically, the Warnings and Restrictions notice in the User's Guide prior to handling the product. This notice contains important safety information about temperatures and voltages. For additional information on TI's environmental and/or safety programs, please contact the TI application engineer or visit [www.ti.com/esh](http://www.ti.com/esh).

No license is granted under any patent right or other intellectual property right of TI covering or relating to any machine, process, or combination in which such TI products or services might be or are used.

## FCC Warning

This evaluation board/kit is intended for use for **ENGINEERING DEVELOPMENT, DEMONSTRATION, OR EVALUATION PURPOSES ONLY** and is not considered by TI to be a finished end-product fit for general consumer use. It generates, uses, and can radiate radio frequency energy and has not been tested for compliance with the limits of computing devices pursuant to part 15 of FCC rules, which are designed to provide reasonable protection against radio frequency interference. Operation of this equipment in other environments may cause interference with radio communications, in which case the user at his own expense will be required to take whatever measures may be required to correct this interference.

## EVM Warnings and Restrictions

It is important to operate this EVM within the input voltage range of 8.5 V to 15 V and the output voltage range of 8.5 V to 15 V .

Exceeding the specified input range may cause unexpected operation and/or irreversible damage to the EVM. If there are questions concerning the input range, please contact a TI field representative prior to connecting the input power.

Applying loads outside of the specified output range may result in unintended operation and/or possible permanent damage to the EVM. Please consult the EVM User's Guide prior to connecting any load to the EVM output. If there is uncertainty as to the load specification, please contact a TI field representative.

During normal operation, some circuit components may have case temperatures greater than 85°C. The EVM is designed to operate properly with certain components above 85°C as long as the input and output ranges are maintained. These components include but are not limited to linear regulators, switching transistors, pass transistors, and current sense resistors. These types of devices can be identified using the EVM schematic located in the EVM User's Guide. When placing measurement probes near these devices during operation, please be aware that these devices may be very warm to the touch.

Mailing Address: Texas Instruments, Post Office Box 655303, Dallas, Texas 75265  
Copyright © 2010, Texas Instruments Incorporated

## IMPORTANT NOTICE

Texas Instruments Incorporated and its subsidiaries (TI) reserve the right to make corrections, modifications, enhancements, improvements, and other changes to its products and services at any time and to discontinue any product or service without notice. Customers should obtain the latest relevant information before placing orders and should verify that such information is current and complete. All products are sold subject to TI's terms and conditions of sale supplied at the time of order acknowledgment.

TI warrants performance of its hardware products to the specifications applicable at the time of sale in accordance with TI's standard warranty. Testing and other quality control techniques are used to the extent TI deems necessary to support this warranty. Except where mandated by government requirements, testing of all parameters of each product is not necessarily performed.

TI assumes no liability for applications assistance or customer product design. Customers are responsible for their products and applications using TI components. To minimize the risks associated with customer products and applications, customers should provide adequate design and operating safeguards.

TI does not warrant or represent that any license, either express or implied, is granted under any TI patent right, copyright, mask work right, or other TI intellectual property right relating to any combination, machine, or process in which TI products or services are used. Information published by TI regarding third-party products or services does not constitute a license from TI to use such products or services or a warranty or endorsement thereof. Use of such information may require a license from a third party under the patents or other intellectual property of the third party, or a license from TI under the patents or other intellectual property of TI.

Reproduction of TI information in TI data books or data sheets is permissible only if reproduction is without alteration and is accompanied by all associated warranties, conditions, limitations, and notices. Reproduction of this information with alteration is an unfair and deceptive business practice. TI is not responsible or liable for such altered documentation. Information of third parties may be subject to additional restrictions.

Resale of TI products or services with statements different from or beyond the parameters stated by TI for that product or service voids all express and any implied warranties for the associated TI product or service and is an unfair and deceptive business practice. TI is not responsible or liable for any such statements.

TI products are not authorized for use in safety-critical applications (such as life support) where a failure of the TI product would reasonably be expected to cause severe personal injury or death, unless officers of the parties have executed an agreement specifically governing such use. Buyers represent that they have all necessary expertise in the safety and regulatory ramifications of their applications, and acknowledge and agree that they are solely responsible for all legal, regulatory and safety-related requirements concerning their products and any use of TI products in such safety-critical applications, notwithstanding any applications-related information or support that may be provided by TI. Further, Buyers must fully indemnify TI and its representatives against any damages arising out of the use of TI products in such safety-critical applications.

TI products are neither designed nor intended for use in military/aerospace applications or environments unless the TI products are specifically designated by TI as military-grade or "enhanced plastic." Only products designated by TI as military-grade meet military specifications. Buyers acknowledge and agree that any such use of TI products which TI has not designated as military-grade is solely at the Buyer's risk, and that they are solely responsible for compliance with all legal and regulatory requirements in connection with such use.

TI products are neither designed nor intended for use in automotive applications or environments unless the specific TI products are designated by TI as compliant with ISO/TS 16949 requirements. Buyers acknowledge and agree that, if they use any non-designated products in automotive applications, TI will not be responsible for any failure to meet such requirements.

Following are URLs where you can obtain information on other Texas Instruments products and application solutions:

<b>Products</b>		<b>Applications</b>	
Amplifiers	<a href="http://amplifier.ti.com">amplifier.ti.com</a>	Audio	<a href="http://www.ti.com/audio">www.ti.com/audio</a>
Data Converters	<a href="http://dataconverter.ti.com">dataconverter.ti.com</a>	Automotive	<a href="http://www.ti.com/automotive">www.ti.com/automotive</a>
DLP® Products	<a href="http://www.dlp.com">www.dlp.com</a>	Communications and Telecom	<a href="http://www.ti.com/communications">www.ti.com/communications</a>
DSP	<a href="http://dsp.ti.com">dsp.ti.com</a>	Computers and Peripherals	<a href="http://www.ti.com/computers">www.ti.com/computers</a>
Clocks and Timers	<a href="http://www.ti.com/clocks">www.ti.com/clocks</a>	Consumer Electronics	<a href="http://www.ti.com/consumer-apps">www.ti.com/consumer-apps</a>
Interface	<a href="http://interface.ti.com">interface.ti.com</a>	Energy	<a href="http://www.ti.com/energy">www.ti.com/energy</a>
Logic	<a href="http://logic.ti.com">logic.ti.com</a>	Industrial	<a href="http://www.ti.com/industrial">www.ti.com/industrial</a>
Power Mgmt	<a href="http://power.ti.com">power.ti.com</a>	Medical	<a href="http://www.ti.com/medical">www.ti.com/medical</a>
Microcontrollers	<a href="http://microcontroller.ti.com">microcontroller.ti.com</a>	Security	<a href="http://www.ti.com/security">www.ti.com/security</a>
RFID	<a href="http://www.ti-rfid.com">www.ti-rfid.com</a>	Space, Avionics & Defense	<a href="http://www.ti.com/space-avionics-defense">www.ti.com/space-avionics-defense</a>
RF/IF and ZigBee® Solutions	<a href="http://www.ti.com/lprf">www.ti.com/lprf</a>	Video and Imaging	<a href="http://www.ti.com/video">www.ti.com/video</a>
		Wireless	<a href="http://www.ti.com/wireless-apps">www.ti.com/wireless-apps</a>

Mailing Address: Texas Instruments, Post Office Box 655303, Dallas, Texas 75265  
Copyright © 2010, Texas Instruments Incorporated