

Molded Parts Specification Control Drawing

Part Number : 214A311 thru 352
Description : Boot, Rectangular, Subminiature,
Straight, Overexpanded

NOTES

- All dimensions are in $\frac{\text{inches}}{\text{[millimeters]}}$
- Dimensions appearing in table are as follows:
a - As Supplied
b - After Unrestricted Recovery
- Coating is optional. As supplied dimensions appearing in table are for uncoated parts. When coating is added, entry diameters will be reduced by .06 max.
- Molding ports are optional. When -00 modification number is specified molding ports will be located as shown.

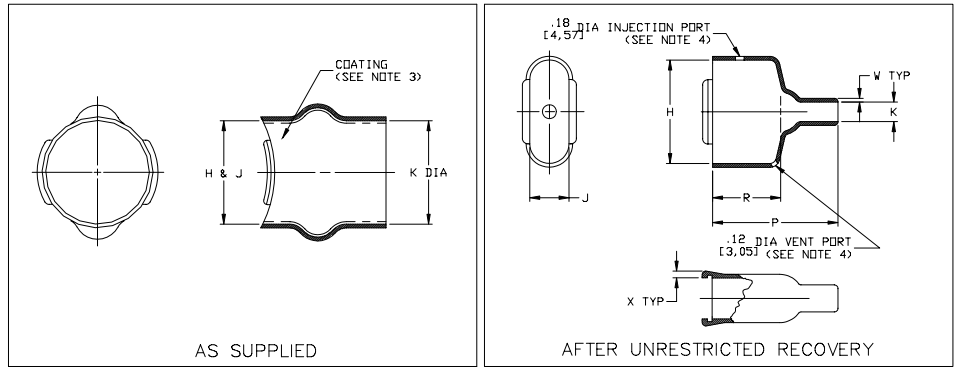

PART NUMBER	H		J		K		P	R	W	X	This Boot Fits					
	Min	±5%	Min	±5%	Min	Max					±10%	±10%	±20%	±20%	Cannon - Cinch	Amphenol Series 17
	a	b	a	b	a	b					b	b	b	b		
214A311	.63 [16,0]	.80 [20,3]	.63 [16,0]	.42 [10,7]	.63 [16,0]	.16 [4,1]	1.31 [33,3]	.75 [19,1]	.04 [1,0]	.12 [3,0]	DE-9	XX09x				
214A321	.75 [19,1]	1.11 [28,2]	.75 [19,1]	.42 [10,7]	.75 [19,1]	.21 [5,3]	1.53 [38,9]	.87 [22,1]	.04 [1,0]	.12 [3,0]	DA-15	XX15x				
214A332	1.15 [29,2]	1.66 [42,2]	1.15 [29,2]	.42 [10,7]	1.15 [29,2]	.32 [8,1]	1.77 [45,0]	1.00 [25,4]	.04 [1,0]	.12 [3,0]	DB-25	XX25x				
214A342	1.35 [34,3]	2.31 [58,7]	1.35 [34,3]	.42 [10,7]	1.35 [34,3]	.34 [8,6]	2.10 [53,3]	1.12 [28,4]	.04 [1,0]	.12 [3,0]	DC-37	XX37x				
214A352	1.48 [37,6]	2.28 [57,9]	1.48 [37,6]	.54 [13,7]	1.48 [37,6]	.42 [10,7]	2.40 [61,0]	1.25 [31,8]	.04 [1,0]	.12 [3,0]	DD-50	XX50x				

If this document is printed it becomes uncontrolled.
Check with the web for latest revision.

tyco Electronics Raychem

TYCO ELECTRONICS
307 CONSTITUTION DRIVE
MENLO PARK, CALIFORNIA 94025

Revision : M
Date : 10/04/01

Part Number : 214A311 thru 352
Description : Boot, Rectangular, Subminiature,
Straight, Overexpanded

Molded Parts Specification Control Drawing

Part Number : 214A311 thru 352
Description : Boot, Rectangular, Subminiature,
Straight, Overexpanded

MATERIAL DASH NO.	MATERIAL DESCRIPTION	RT SPEC	COATING SLASH NO.	COATING S NO.	COATING DESCRIPTION
-3	Polyolefin, Semi-rigid	RT-301	/42;/86	S-1017;S-1048	Adhesive
-4	Polyolefin, Flexible	RT-1304	/42;/86	S-1017;S-1048	Adhesive
-5	Elastomer, Flexible	RT-501	/42	S-1017	Adhesive
-8	Polyolefin, Space	RT-1308	N/A		
-25	Elastomer, Fluid Resistant	RT-1325	/86;/225	S-1048;S-1206	Adhesive
-100	Polyolefin Semi-Flexible ZEROHAL™	RT-1323	/86	S-1048	Adhesive

ORDERING INFORMATION

214A3XX -XX -XX /XXX

Base part number _____

Material dash number _____
(See Compatibility Chart)

Modification number _____
(If necessary, see front of scd binder for a complete list)

Adhesive slash number _____
(If necessary, see Compatibility Chart)

THIS DRAWING IS SUBJECT TO CHANGE WITHOUT NOTICE; CONSULT YOUR NEAREST FIELD REPRESENTATIVE FOR CURRENT REVISION

If this document is printed it becomes uncontrolled.
Check with the web for latest revision.

tyco Electronics Raychem

TYCO ELECTRONICS
307 CONSTITUTION DRIVE
MENLO PARK, CALIFORNIA 94025

Revision : M
Date : 10/04/01

Part Number : 214A311 thru 352
Description : Boot, Rectangular, Subminiature,
Straight, Overexpanded

CAD FILE MP01084