

THIS DRAWING IS UNPUBLISHED. RELEASED FOR PUBLICATION
 © COPYRIGHT - By - ALL RIGHTS RESERVED.

LOC	DIST	REVISIONS					
		P	LTR	DESCRIPTION	DATE	DWN	APVD
AA	00	B1		REVISED PER ECO-11-005033	23MAR11	RK	HMR

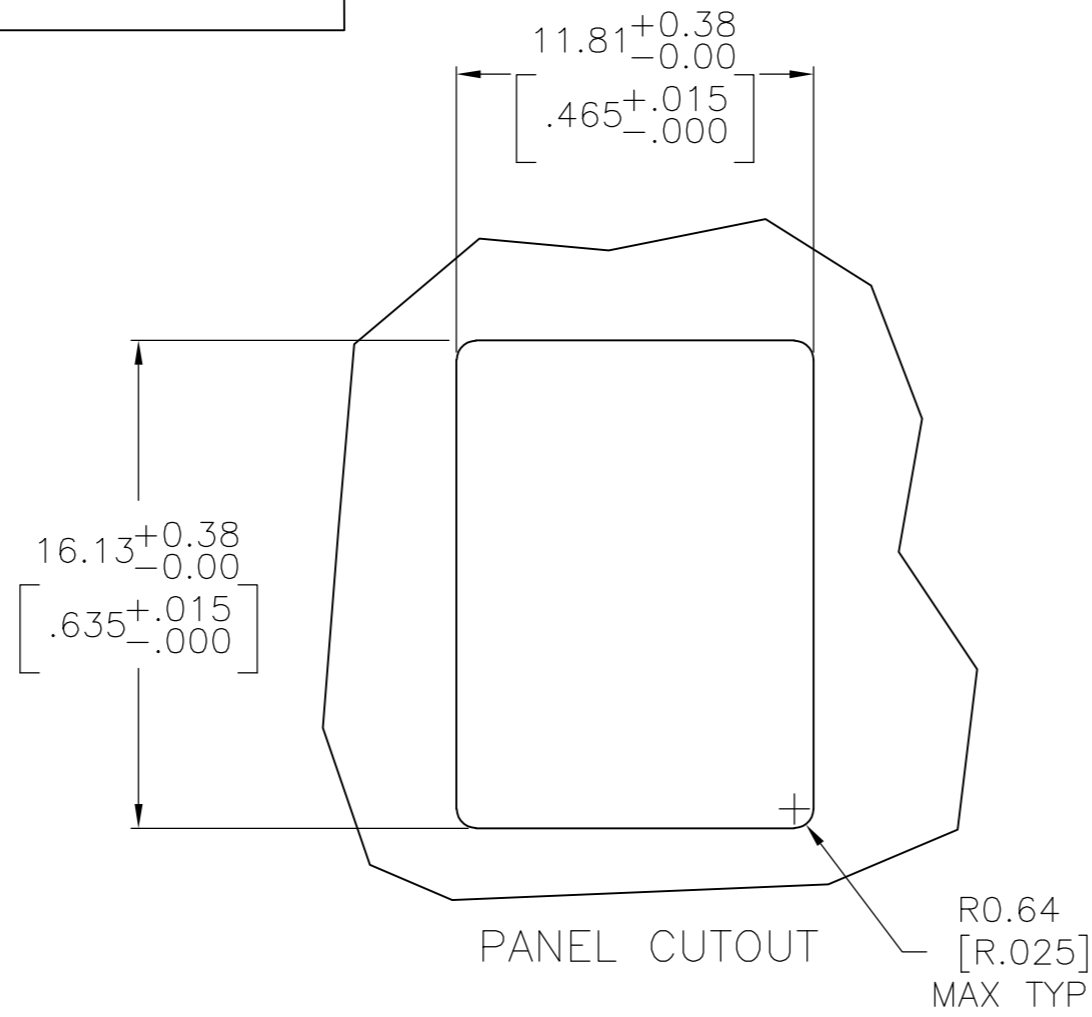
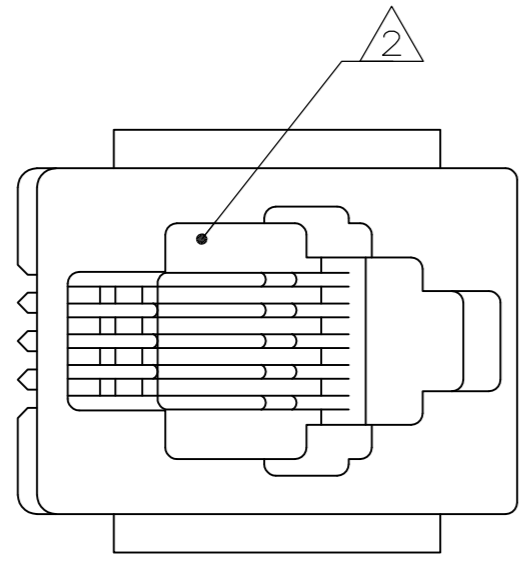

1. MATERIAL: HOUSING - PBT POLYESTER, COLOR: BLACK.
 TERMINAL - 0.36[.014] THICK PHOS BRONZE PLATED WITH 1.27μm[.000050] MINIMUM THICK HARD GOLD IN LOCALIZED GOLD PLATE AREA AND 3.81μm[.000150] MINIMUM THICK MATTE TIN IN SOLDER AREA OVER 1.27μm[.000050] MINIMUM THICK NICKEL UNDERPLATE.

△2 CAVITY CONFORMS TO FCC RULES AND REGULATIONS PART 68 AND REA BULLETIN 345-.81 PE-76 SPECIFICATION FOR MODULAR TELEPHONE HARDWARE.

△3 BULK PACKAGED IN A TRAY.

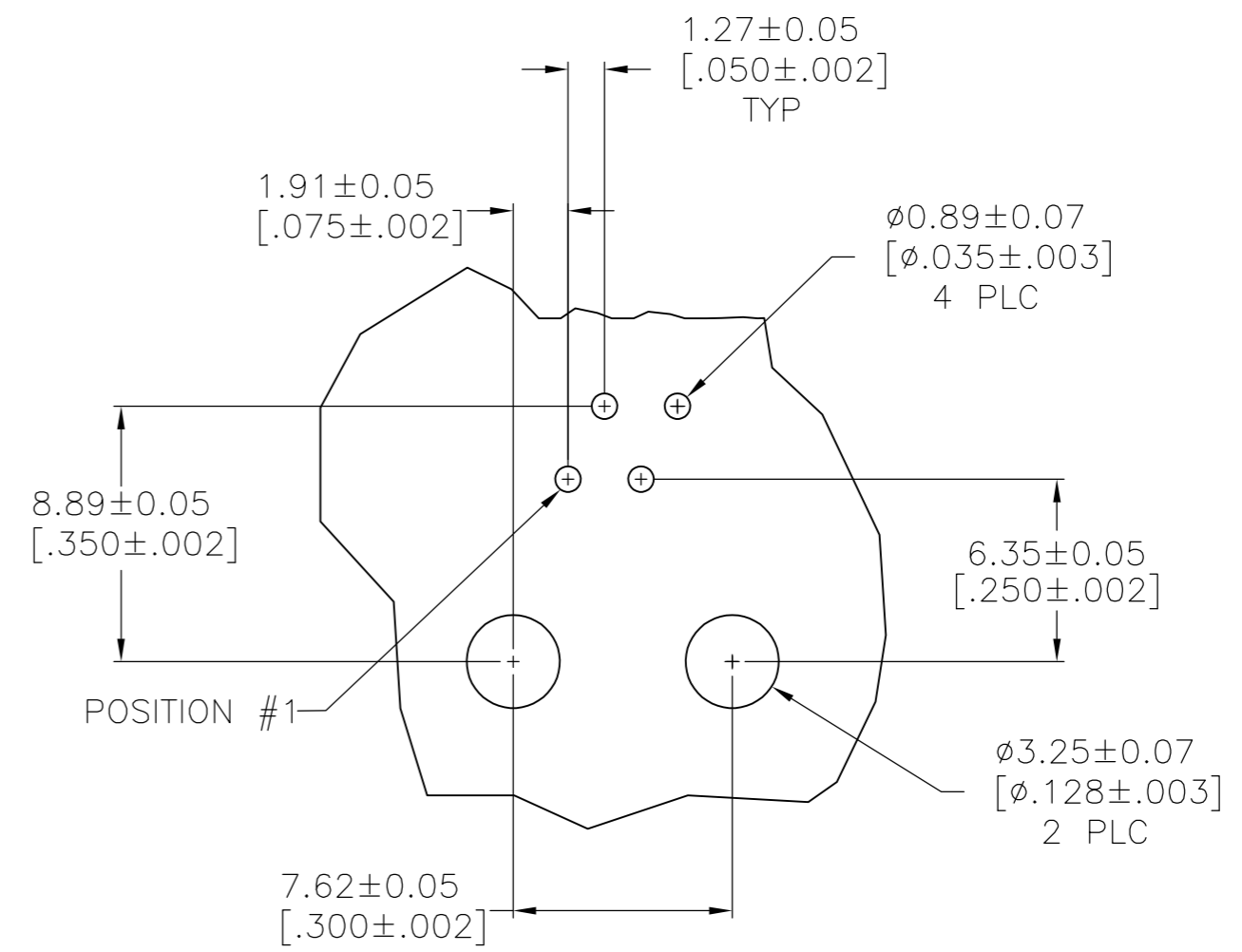
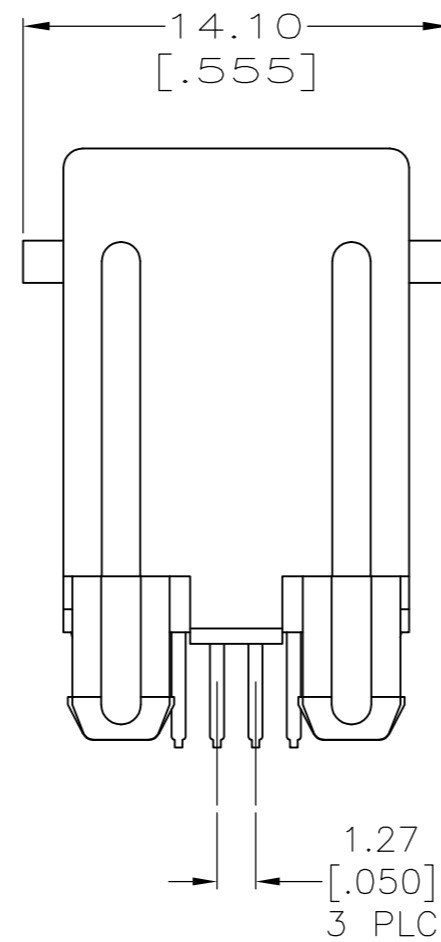
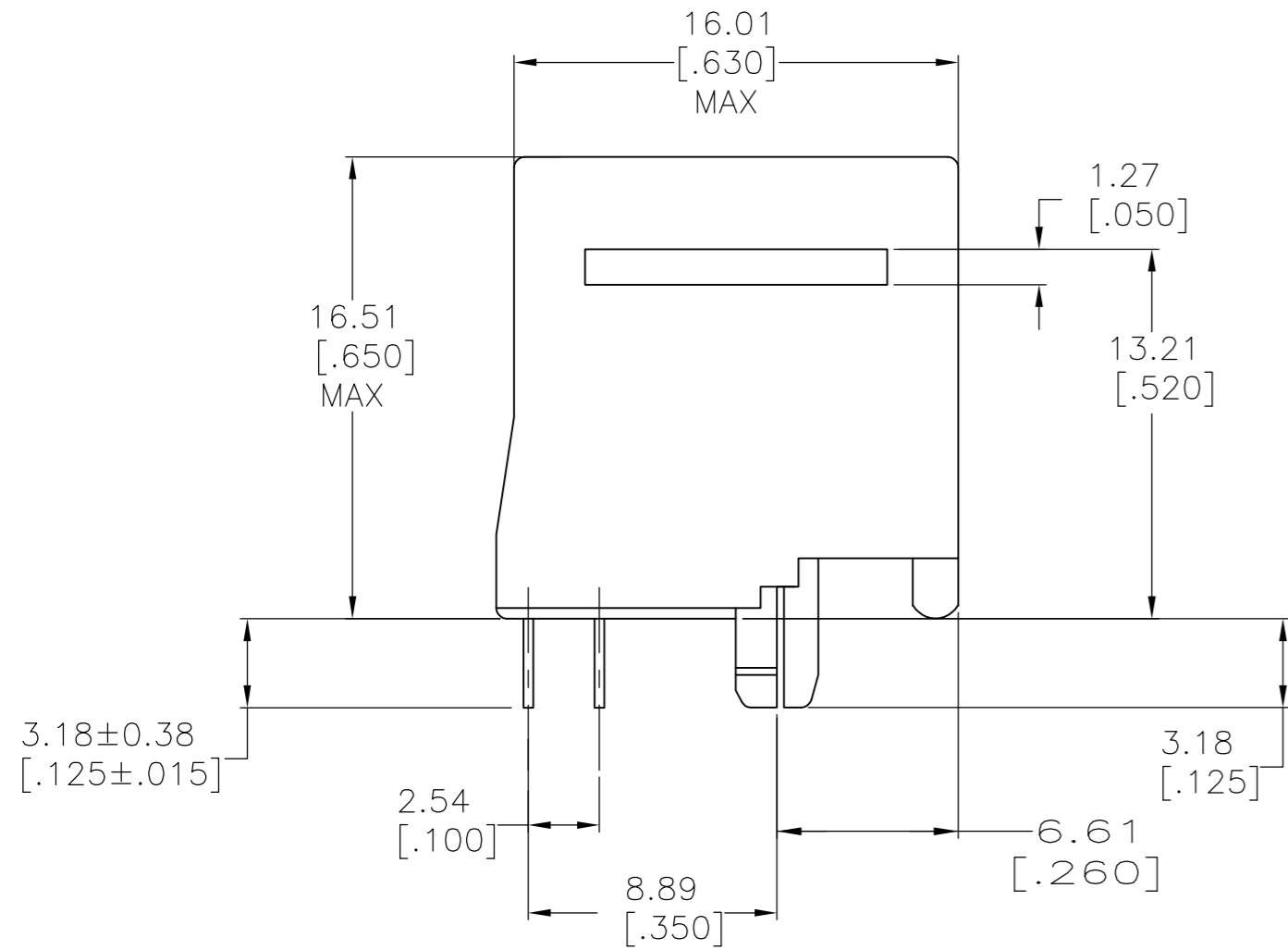

SUGGESTED PRINTED CIRCUIT BOARD LAYOUT COMPONENT SIDE

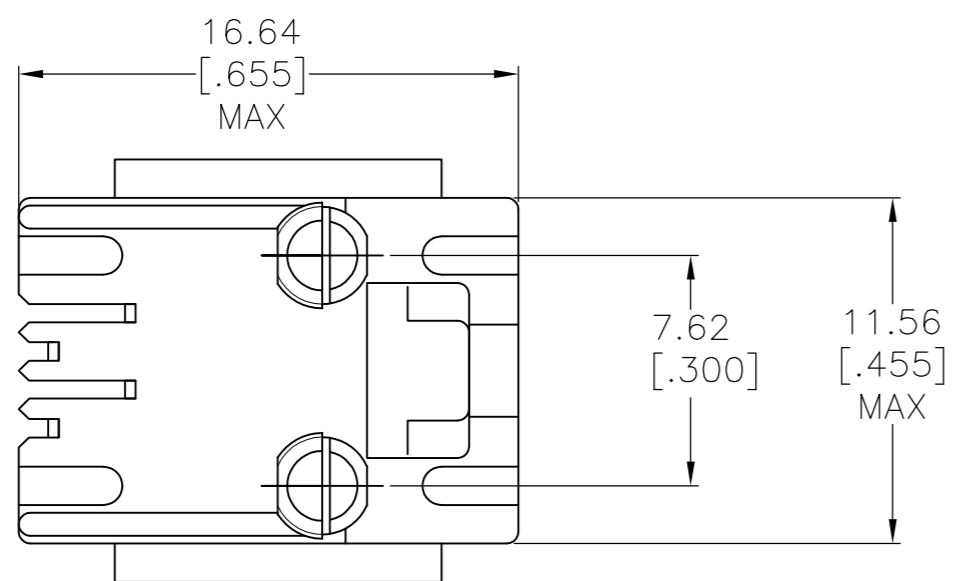

△3	5520257-2
PACKAGED	PART NUMBER

THIS DRAWING IS A CONTROLLED DOCUMENT.		DWN L.A.MAYER 16AUG2007	TE Connectivity	
DIMENSIONS: mm [INCHES]		CHK P.RECCE 16AUG2007		
TOLERANCES UNLESS OTHERWISE SPECIFIED:		APVD S.FLICKINGER 16AUG2007	NAME	
0 PLC ± -		PRODUCT SPEC	108-1163	
1 PLC ± -		APPLICATION SPEC	114-2048	
2 PLC ± 0.13[.005]		WEIGHT	-	
3 PLC ± -		CUSTOMER DRAWING	SCALE 4:1 SHEET 1 OF 1 REV B1	
4 PLC ± -				
ANGLES ± -				
FINISH				
SEE NOTE 1				