

PART NUMBER	SSH-LX3050	REV.	D
DATE	E.C.N. NUMBER AND REVISION COMMENTS	REV.	
09.15.99	E.C.N. #10BRDR. & REDRAWN.	A	
02.18.99	E.C.N. #10BRDR. & REDRAWN.	B	
08.07.11	E.C.N. #10BRDR. & REDRAWN.	C	
05.05.11	E.C.N. #10BRDR. & REDRAWN.	D	

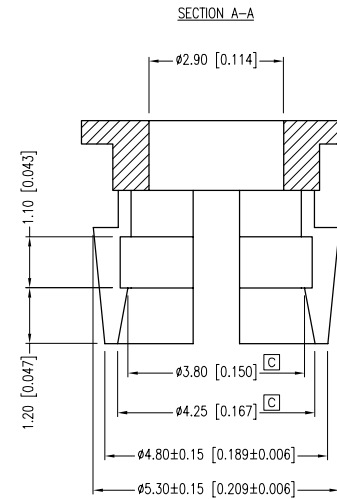

NOTES:

1. MATERIAL: POLYPROPYLENE (PP), BLACK.
2. PANEL HOLE CUT OUT: 4.45mm [0.175"].
3. PANEL THICKNESS: 1.65mm [0.065"].
4. CAVITY NUMBER.
5. LX MARKING.

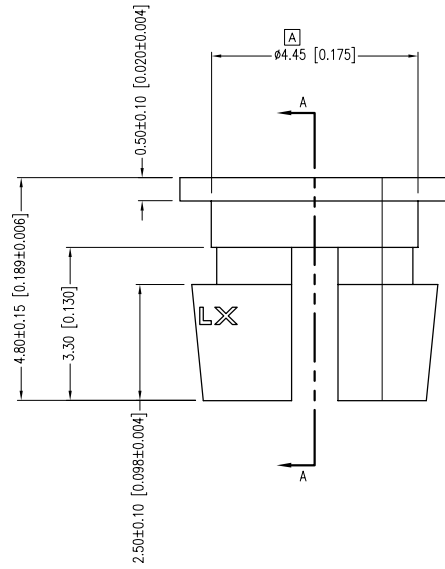
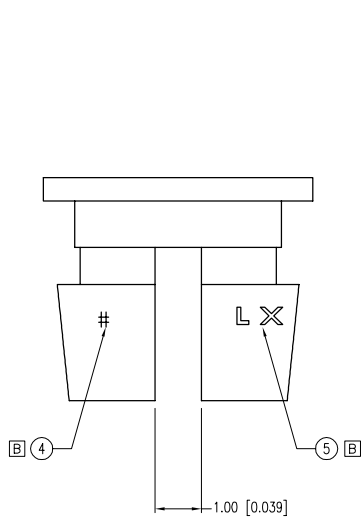
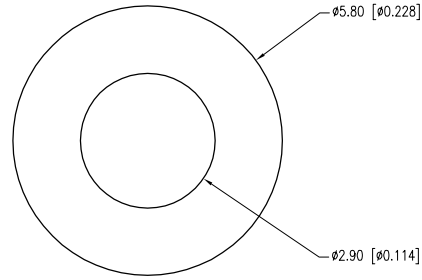
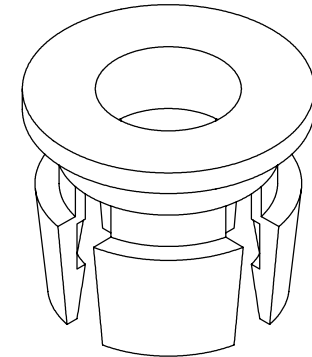
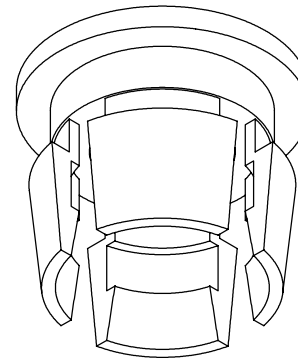
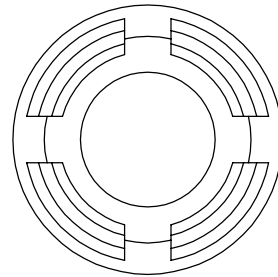
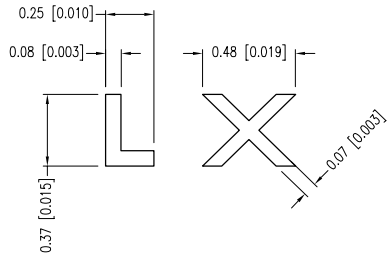

\*UNLESS OTHERWISE SPECIFIED TOLERANCES PER DECIMAL PRECISION ARE: X=±1 (±0.039), X.X=±0.5 (±0.020), X.XX=±0.25 (±0.010), X.XXX=±0.127 (±0.005). LEAD SIZE=±0.05 (±0.002), LEAD LENGTH=±0.75 (±0.030). MIN.= +<sup>DECIMAL PRECISION</sup> -<sub>DECIMAL PRECISION</sub>

UNCONTROLLED DOCUMENT



290 E. HELEN ROAD  
PALATINE, IL 60067-6976  
PHONE: +1.847.359.2790  
FAX: +1.847.359.6538  
WEB: WWW.LUMEX.COM

3mm LED PANEL CLIP FOR LX3050 TYPES.

\*\*THE SPECIFICATIONS MAY CHANGE AT ANY TIME WITHOUT NOTICE DUE TO NEW MATERIALS OR PRODUCT IMPROVEMENT.\*\*

CONFIDENTIAL INFORMATION  
THE INFORMATION CONTAINED IN THIS DOCUMENT IS THE PROPERTY OF LUMEX INC. EXCEPT AS SPECIFICALLY AUTHORIZED IN WRITING BY LUMEX INC., THE HOLDER OF THIS DOCUMENT SHALL KEEP ALL INFORMATION CONTAINED HEREIN CONFIDENTIAL AND SHALL PROTECT SAME IN WHOLE OR IN PART FROM DISCLOSURE AND DISSEMINATION TO ALL THIRD PARTIES.

DATE:	05.05.11	DRAWN BY:	AB
PAGE:	1 OF 1	CHKD BY:	KF
SCALE:	NTS	APRVD BY:	SS
UNIT:	mm [INCH]		Ⓟ