

# Intel® Enpirion® Power Solutions

## EM22xx Evaluation Board User Guide

### User Guide

© 2017 Intel Corporation. All rights reserved. Intel, the Intel logo, Altera, Enpirion, and the Enpirion logo are trademarks of Intel Corporation in the US and/or other countries. Other marks and brands may be claimed as the property of others. Intel warrants performance of its FPGA and semiconductor products to current specifications in accordance with Intel's standard warranty, but reserves the right to make changes to any products and services at any time without notice. Intel assumes no responsibility or liability arising out of the application or use of any information, product, or service described herein except as expressly agreed to in writing by Intel. Intel customers are advised to obtain the latest version of device specifications before relying on any published information and before placing orders for products or services.



## Contents

---

1. Description.....	3
2. Required Equipment.....	3
3. Evaluation Board Overview.....	4
4. Instructions.....	5
5. Evaluation Board Schematic.....	7
6. Bill of Materials.....	9
7. Revision History .....	11

## List of Figures

Figure 1: EM22xx Evaluation Board Overview (View From Top - EM2260 shown as an example).....	4
Figure 2: Jumper Table, Marked On The EM22xx Evaluation Board Silk Screen .....	6
Figure 3: Evaluation Board Schematic – Power.....	7
Figure 4: Evaluation Board Schematic – AUX.....	8

## List of Tables

Table 1: Required Equipment.....	3
Table 2: Bill of Materials.....	9



## 1. Description

The EM22xx family are PowerSoC synchronous Dual Phase buck converters from the Intel® Enpirion® Power Solutions family. The EM22xx series feature an advanced controller, gate drivers, synchronous MOSFET switches, and high performance inductors. Only input and output filter capacitors and a few small signal components are required for a complete solution.

Differential remote sensing and  $\pm 0.5\%$  set-point accuracy provide precise regulation over line, load and temperature variation. Very low ripple further reduces accuracy uncertainty to provide best in class static regulation for today's FPGAs, ASICs, processors, and DDR memory devices.

## 2. Required Equipment

**Table 1: Required Equipment**

Item #	Equipment	Recommended
1	DC Power Supply	20V/30A, adjustable
2	Electronic Load	50...100A with dynamic load capabilities
3	Intel Enpirion PMBus Communication Interface Dongle	
4	Intel 25A Mini Slammer Loads	Fits the on-board LD1, LD2 & LD3 socket
5	DMM	6 ½ digit
6	Oscilloscope	4 channels, 0.5 GHz BW
7	Cables	>60A capability, eyelet terminal, 4 mm diameter hole, 10 mm outer diameter

### 3. Evaluation Board Overview

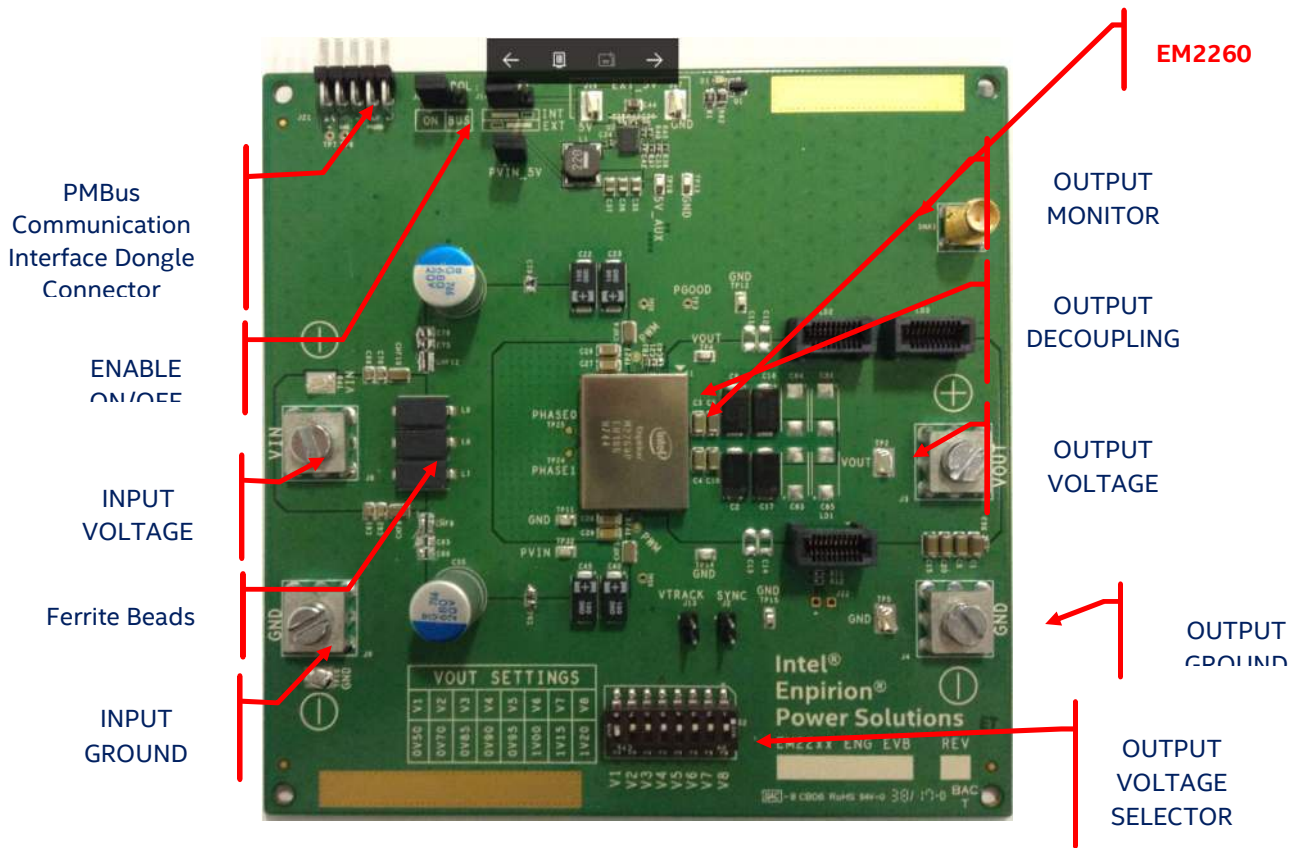

Figure 1: EM22xx Evaluation Board Overview (View From Top - EM2260 shown as an example)



## 4. Instructions

---

### 1) Connect the power supply

- Set the Power Supply to 12V/10A.
- Connect the power supply to the board (make sure that the power supply is OFF) with two patch cables, not longer than 6 inches (15 cm). Using longer wires is possible, provided that additional bulk is added to the board and the input voltage is monitored at the board level. For lower Input voltages e.g. 5V further bulk capacitance maybe required depending on the Power Supply being used. Please use INPUT GROUND and INPUT VOLTAGE eyelet-terminated cables to connect the power.
- Please observe the correct polarity.



**CAUTION:** *Incorrect polarity of the power supply may cause permanent board damage!*

**CAUTION:** *Power supply voltage above 20V may cause permanent board damage!*

### 2) Connect the load

- Connect the load to the OUTPUT GROUND and OUTPUT voltage with patch cables, no longer than 6 inches (15 cm).
- Please observe the correct polarity.

### 3) Check jumper settings

- The board will arrive with one jumper on the J6 (enabling the Output through pulling the CTRL pin high), one jumper on J14 (INT – this connects the on-board 5VCC supply) and one jumper on J15 (PVIN\_5V – this biases the 5V on board DC-DC converter). If an auxiliary 5V power supply is needed (connected between J16 (+) and J17 (-)), J14 should be placed across the “EXT” position while J15 can be removed. If operating PVIN at 6V or lower an external 5V supply is required to ensure correct operation. (For PVIN values below 6V the on-board switcher cannot guarantee a 5Vout output)

### 4) Connect the PMBUS GUI interface dongle

- The USB Dongle can be inserted only in the correct position, with pin one towards GND. All pins must be properly inserted.
- Prerequisite: the latest GUI software must be installed on a Windows PC.



**5) Set the output voltage**

- Using the chart from the silkscreen, please select the desired output voltage, using ONLY ONE switch ON. This setting will be read by the module when the part is powered on; changing the resistor on the fly will not have any effect.

**6) Power-up the board**

- After all preparations above, the board should be ready to perform.
- The voltage range is marked on the board, as shown in Figure 2:

**Vout Settings**

0V50	V1
0V70	V2
0V85	V3
0V90	V4
0V95	V5
1V00	V6
1V15	V7
1V20	V8

**Figure 2: Jumper Table, Marked On The EM22xx Evaluation Board Silk Screen**

- For instruction on how to use the EM22xx GUI, please read “GUI User Guide.”

**NOTE:** To measure the Bode Plot of the DC-DC converter, J12 must be populated which is then used to connect the probes of the phase analyzer.



## 5. Evaluation Board Schematic

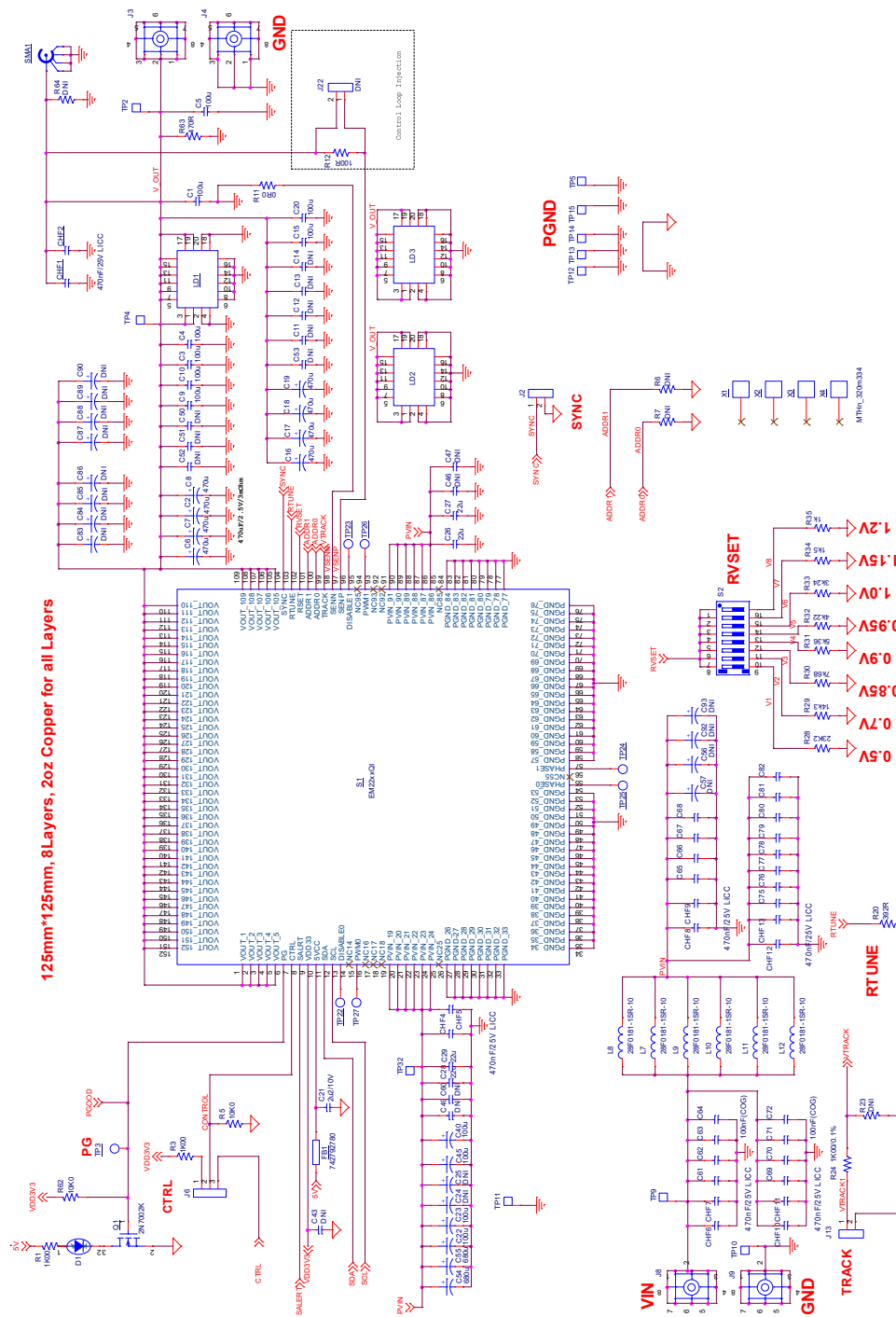

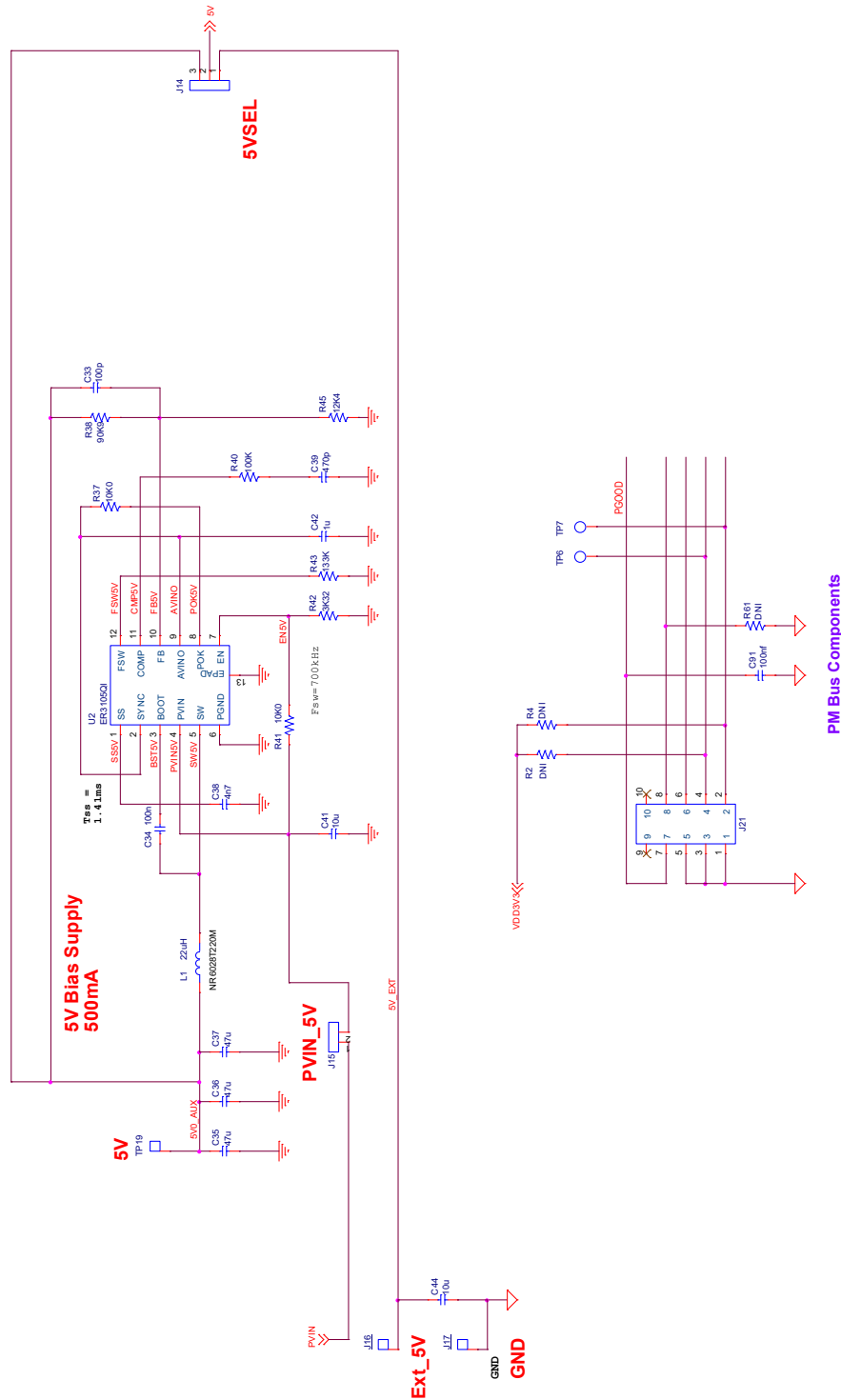

Figure 4: Evaluation Board Schematic – AUX





## 6. Bill of Materials

Table 2: Bill of Materials

Type	Description	Qty.	BOM Ref Des	Mfr. Name
Capacitor	100μF 6V3 10% X5R 1206	8	C1,C3,C4,C5,C9,C10,C15,C20	Kemet
Capacitor	470μF 2.5V 3 mΩ	8	C2,C6,C7,C8,C16,C17,C18,C19	Panasonic
Capacitor	2.2μF 16V 10% X6S 0402	1	C21	TDK
Capacitor	100μF, 20V, ESR=55 mΩ	4	C22 C23 C40 C45	Panasonic
Capacitor	22μF 25V 10% X5R 1206	4	C26,C27,C28,C29	Murata
Capacitor	100pF 50V 5% NPO 0402	1	C33	Taiyo Yuden
Capacitor	100nF X7R 0402 10V 10%	1	C34	Murata
Capacitor	47μF 6.3V X5R 0805	3	C35,C36,C37	Taiyo Yuden
Capacitor	4.7nF X7R 0402 25V 10%	1	C38	Murata
Capacitor	470pF 25V X7R 10% 0402	1	C39	Vishay
Capacitor	10μF 25V X5R 0805 10%	2	C41,C44	
Capacitor	1μF 25V 20% X5R 0402	1	C42	Taiyo Yuden
Capacitor	470nF 25V 20% X7R 0612	12	CHF1,CHF2,CHF4,CHF5, CHF6,CHF7,CHF8,CHF9, CHF10,CHF11,CHF12,CHF13	Murata
Capacitor	680UF 20% 20V T/H	2	C54,C55	Chemi-com
Capacitor	100nF X7R 0805 25V	20	C61,C62,C63,C64,C65,C66,C67,C68 C69,C70,C71,C72, C75,C76,C77 C78,C79,C80,C81,C82	Murata
Resistor	1k 1% 0805	1	R1	Panasonic
Resistor	1k 1% 0402	1	R3	Panasonic



Type	Description	Qty.	BOM Ref Des	Mfr. Name
Resistor	RES 10k OHM 1% 0402	3	R5,R37,R41	Panasonic
Resistor	0 OHM 5% 0402	1	R11	Panasonic
Resistor	100R OHM 1% 0402	1	R12	Panasonic
Resistor	392 OHM 0.1% 0603	1	R20	Panasonic
Resistor	1K OHM 0.1% 0402	1	R24	Panasonic
Resistor	23.2K OHM 1% 0402	1	R28	Panasonic
Resistor	14.3K 0603 1%,	1	R29	Panasonic
Resistor	7.68K OHM 1% 0603	1	R30	Panasonic
Resistor	5.36K OHM 1% 0603	1	R31	Panasonic
Resistor	4.22K OHM 1% 0603	1	R32	Panasonic
Resistor	3.24K OHM 0603 1%	1	R33	Panasonic
Resistor	1K5 OHM 0603 1%	1	R34	Panasonic
Resistor	1K OHM 1% 0603	1	R35	Panasonic
Resistor	90.9K OHM 1% 0402	1	R38	Yageo
Resistor	100K OHM 1% 0402	1	R40	Panasonic
Resistor	3.32K OHM 1% 0402	1	R42	Panasonic
Resistor	133K OHM 1% 0402	1	R43	Panasonic
Resistor	12.4K OHM 1% 0402	1	R45	Panasonic
Resistor	10K OHM 1% 0805	1	R62	Panasonic
Resistor	470R OHM 5% 0603	1	R63	Panasonic
LED	LED GREEN CLEAR 0603	1	D1	LITE-ON INC
Inductor	INDUCTOR, 22UH, 1.3A,	1	L1	Taiyo Yuden
Inductor	Ferrite Bead, 115 ohm, 10 A, 1000 µohm	6	L7,L8,L9,L10,L11,L12	Laird Tech
MOSFET	MOSFET N-CH 60V 300MA SOT23	1	Q1	Fairchild
Inductor	FERRITE BEAD 220 OHM 0402	1	FB1	Würth
Connector	INTEL 25A SLAMER LOAD CONNECTOR	3	LD1, LD2, LD3	Samtec
IC	ER3105DI Wide VIN 500mA Synch Buck Reg	1	U2	Intel Enpirion

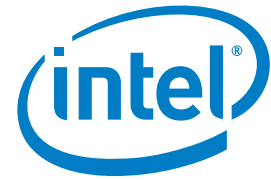

## 7. Revision History

---

Revision Number	Description	Revision Date
001	Initial release.	December 2017
002	Minor updates relating to RVSET resistor values	March 2018

© 2017 Intel Corporation. All rights reserved. Intel, the Intel logo, Altera, Enpirion, and the Enpirion logo are trademarks of Intel Corporation in the US and/or other countries. Other marks and brands may be claimed as the property of others. Intel warrants performance of its FPGA and semiconductor products to current specifications in accordance with Intel's standard warranty, but reserves the right to make changes to any products and services at any time without notice. Intel assumes no responsibility or liability arising out of the application or use of any information, product, or service described herein except as expressly agreed to in writing by Intel. Intel customers are advised to obtain the latest version of device specifications before relying on any published information and before placing orders for products or services.