

**SCREW MALE HERMETIC RECEPTACLE
WITH CYLINDRICAL CONTACT**

R128.639.100

Series : BMA

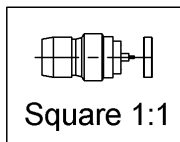
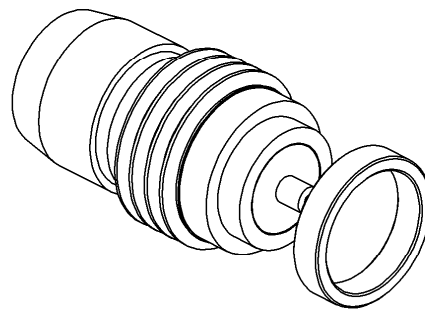
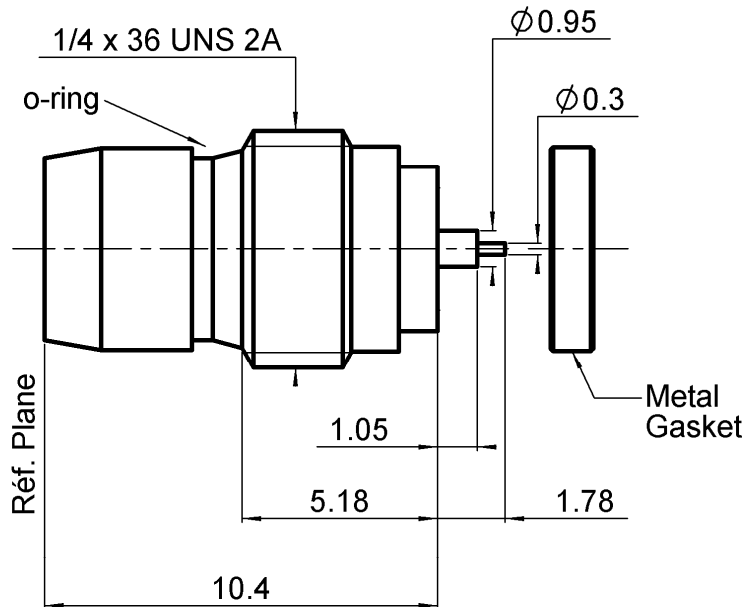

All dimensions are in mm.

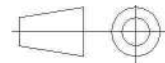

COMPONENTS	MATERIALS	PLATING (µm)
BODY	STAINLESS STEEL	PASSIVATED.
CENTER CONTACT	BERYLLIUM COPPER	GOLD 1.3 OVER NICKEL2
OUTER CONTACT	-	-
INSULATOR	PTFE	-
GASKET	-	-
OTHERS PARTS	SILICONE RUBBER	-
-	-	-
-	-	-

Issue : 1222 A

In the effort to improve our products, we reserve the right to make changes judged to be necessary.



**SCREW MALE HERMETIC RECEPTACLE
WITH CYLINDRICAL CONTACT**

R128.639.100

Series : BMA

PACKAGING

Standard	Unit	Other
1 00	'W' option	Contact us

SPECIFICATION

ELECTRICAL CHARACTERISTICS

Impedance	50	Ω
Frequency	0-22	GHz
VSWR	1.25* + 0,0000	x F(GHz) Maxi
Insertion loss	0.07	\sqrt{F} (GHz) dB Maxi
RF leakage	- (NA)	- F(GHz)) dB Maxi
Voltage rating	500	Veff Maxi
Dielectric withstanding voltage	1500	Veff mini
Insulation resistance	5000	M Ω mini

ENVIRONMENTAL

Operating temperature	-65+125	$^{\circ}$ C
Hermetic seal	10-8	Atm.cm3/s
Panel leakage	IP68	

OTHER CHARACTERISTICS

Assembly instruction

Others :

* DC-10GHz

MECHANICAL CHARACTERISTICS

Center contact retention		
Axial force – Mating end	27	N mini
Axial force – Opposite end	27	N mini
Torque	NA	N.cm mini
Recommended torque		
Mating		N.cm
Panel nut	280	N.cm
Mating life	1000	Cycles mini
Weight	1,2000	g

Issue : 1222 A

In the effort to improve our products, we reserve the right to make changes judged to be necessary.



**SCREW MALE HERMETIC RECEPTACLE
WITH CYLINDRICAL CONTACT**

R128.639.100

Series : BMA

PANEL DRILLING

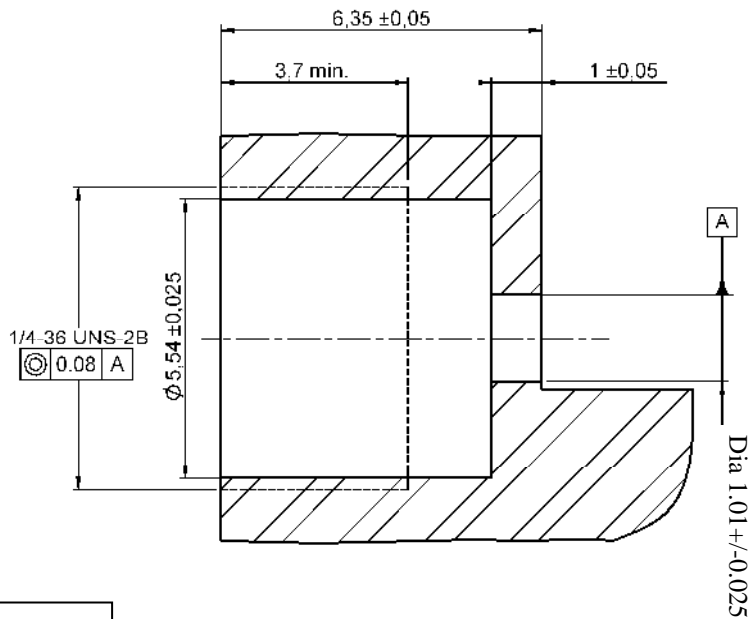

MOUNTING HOLE DETAIL

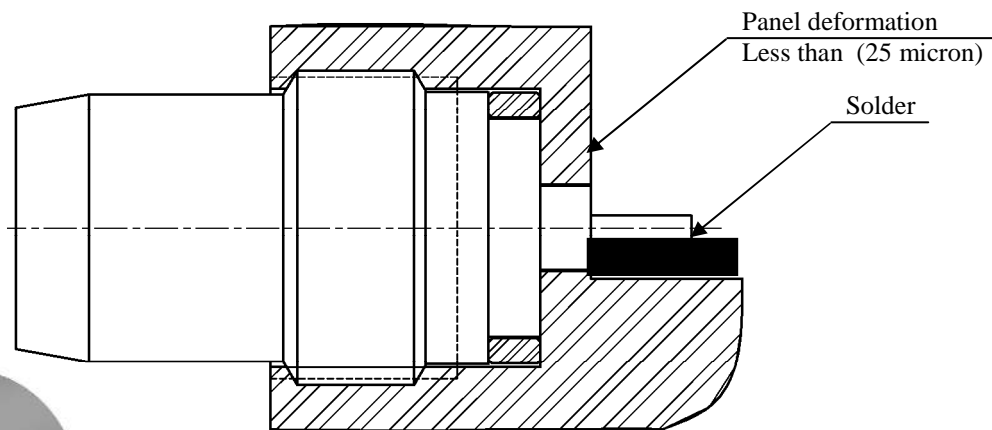

Assemble metal gasket onto connector.
Screw both parts into the housing.
Tighten the connector up to 280 Ncm torque (use special tooling set RADIALL R282 340).
Thus the connection hermeticity is guaranteed at $1 \cdot 10^{-8} \text{ atm.cm}^3/\text{sec}$.
Then solder the pin.
Be careful not put too much solder.

Issue : 1222 A

In the effort to improve our products, we reserve the right to make changes judged to be necessary.

