



# MAXIM

## 500MHz to 2500MHz VCO Buffer Amplifiers

MAX2472/MAX2473

### General Description

The MAX2472/MAX2473 are flexible, wideband, high-reverse-isolation buffer amplifiers. The MAX2472 has dual open-collector outputs capable of delivering -5dBm into 50Ω while maintaining harmonic suppression below -25dBc. The MAX2473 has a single open-collector output with a bias control pin to vary output power from -10dBm to -2dBm while maintaining harmonic suppression below -25dBc. The MAX2472/MAX2473's combination of high reverse isolation and low supply current makes them ideal for applications requiring high performance with low power. They feature high input impedance and open-collector outputs for maximum flexibility, enabling them to be used with a variety of oscillator topologies.

Both the MAX2472 and MAX2473 operate from a single +2.7V to +5.5V supply. With  $V_{CC} = +3.0V$  and -25dBm input power, the MAX2472 consumes 5.2mA, while the MAX2473 consumes only 2.7mA. Both devices are available in a tiny 6-pin SOT23 package requiring minimal board space.

### Applications

- Cellular and PCS Mobile Phones
- Private Mobile Radios
- ISM-Band Applications
- IF/RF Oscillators
- General-Purpose Buffers/Amplifiers

Typical Operating Circuits appear at end of data sheet.

### Pin Configuration

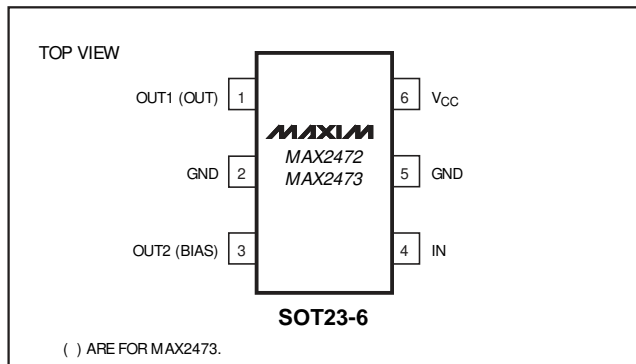

### Features

- ◆ +2.7V to +5.5V Supply Range
- ◆ 500MHz to 2500MHz Input Frequency Range
- ◆ High Reverse Isolation: 49dB at 900MHz
- ◆ Dual Open-Collector Outputs (MAX2472)
- ◆ Adjustable -10dBm to -2dBm Output Power Control (MAX2473)
- ◆ High Input Impedance:  $>250\Omega$  at 900MHz
- ◆ Ultra-Small SOT23-6 Package

### Ordering Information

PART	TEMP. RANGE	PIN-PACKAGE	SOT TOP MARK
MAX2472EUT-T	-40°C to +85°C	6 SOT23-6	AAAZ
MAX2473EUT-T	-40°C to +85°C	6 SOT23-6	AABA

### Functional Diagrams

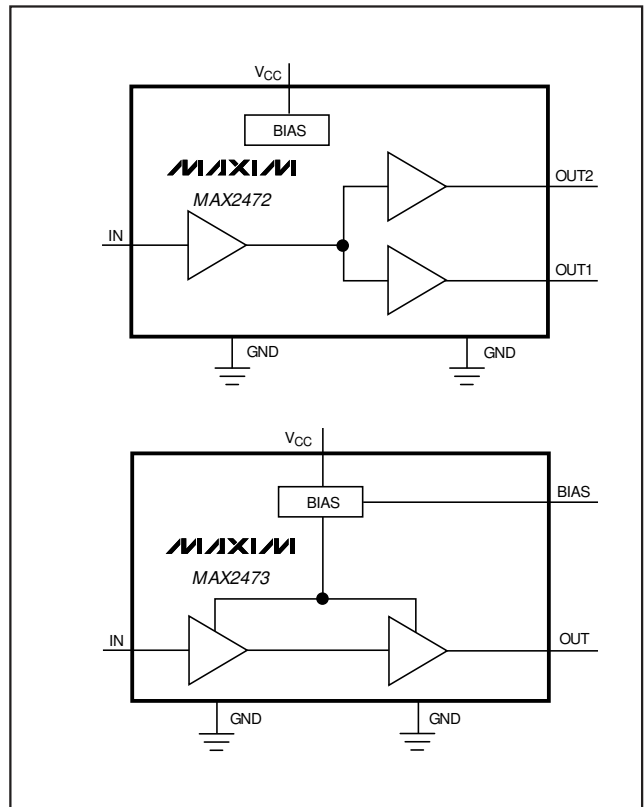

# 500MHz to 2500MHz VCO Buffer Amplifiers

## ABSOLUTE MAXIMUM RATINGS

V<sub>CC</sub> to GND .....-0.3V to +7V  
 OUT1, OUT2, BIAS to GND.....-0.3V to (V<sub>CC</sub> + 0.3V)  
 Maximum BIAS Pin Current.....150μA  
 Maximum Input Power.....+10dBm  
 Continuous Power Dissipation  
 SOT23-6 (derate 8.7mW/°C above +70°C).....696mW

Operating Temperature Range .....-40°C to +85°C  
 Junction Temperature .....+150°C  
 Storage Temperature Range .....-65°C to +150°C  
 Lead Temperature (soldering, 10sec) .....+300°C

Stresses beyond those listed under "Absolute Maximum Ratings" may cause permanent damage to the device. These are stress ratings only, and functional operation of the device at these or any other conditions beyond those indicated in the operational sections of the specifications is not implied. Exposure to absolute maximum rating conditions for extended periods may affect device reliability.

## DC ELECTRICAL CHARACTERISTICS

(V<sub>CC</sub> = +2.7V to +5.5V, P<sub>IN</sub> = -25dBm, I<sub>N</sub> driven from a 50Ω source, OUT<sub>LC</sub>-matched to 50Ω, T<sub>A</sub> = T<sub>MIN</sub> to T<sub>MAX</sub>, unless otherwise noted. Typical values are at V<sub>CC</sub> = +3V, T<sub>A</sub> = +25°C.) (Note 1)

PARAMETER	SYMBOL	CONDITIONS	MIN	TYP	MAX	UNITS	
Input Voltage Range	V <sub>CC</sub>		2.7		5.5	V	
Supply Current	I <sub>CC</sub>	MAX2472		5.2	8.0	mA	
		MAX2473, R <sub>BIAS</sub> = 23kΩ		2.7			
		MAX2473, R <sub>BIAS</sub> = 11kΩ		4.8			
		No drive	MAX2472		5.1		
			MAX2473, R <sub>BIAS</sub> = 23kΩ		2.5		
MAX2473, R <sub>BIAS</sub> = 11kΩ		4.3					

## AC ELECTRICAL CHARACTERISTICS—MAX2472

(Typical Operating Circuits, V<sub>CC</sub> = +3V, P<sub>IN</sub> = -25dBm, I<sub>N</sub> driven from a 50Ω source, OUT1 and OUT2 LC matched to 50Ω, T<sub>A</sub> = +25°C, unless otherwise noted.)

PARAMETER	SYMBOL	CONDITIONS	MIN	TYP	MAX	UNITS
Input Frequency Range (Note 2)	f <sub>IN</sub>		500		2500	MHz
Transducer Gain (IN to OUT2)	S <sub>21</sub>   <sup>2</sup>	f <sub>IN</sub> = 600MHz		14.0		dB
		f <sub>IN</sub> = 900MHz, T <sub>A</sub> = +25°C	7.8	10.2	12.2	
		f <sub>IN</sub> = 900MHz, T <sub>A</sub> = T <sub>MIN</sub> to T <sub>MAX</sub> (Note 3)	6.6		14.6	
		f <sub>IN</sub> = 1900MHz		7.5		
		f <sub>IN</sub> = 2400MHz		6.0		
Transducer Gain (IN to OUT1)	S <sub>21</sub>   <sup>2</sup>	f <sub>IN</sub> = 600MHz		13.0		dB
		f <sub>IN</sub> = 900MHz		9.2		
		f <sub>IN</sub> = 1900MHz		6.8		
		f <sub>IN</sub> = 2400MHz		5.3		
Output 1dB Compression Point	P <sub>OUT1dB</sub>	f <sub>IN</sub> = 900MHz		-3.2		dBm
Reverse Isolation (IN to OUT2)	S <sub>12</sub>   <sup>2</sup>	f <sub>IN</sub> = 600MHz		43		dB
		f <sub>IN</sub> = 900MHz		40		
		f <sub>IN</sub> = 1900MHz		30		
		f <sub>IN</sub> = 2400MHz		26		

# 500MHz to 2500MHz VCO Buffer Amplifiers

MAX2472/MAX2473

## AC ELECTRICAL CHARACTERISTICS—MAX2472 (continued)

(Typical Operating Circuits,  $V_{CC} = +3V$ ,  $P_{IN} = -25dBm$ , IN driven from a  $50\Omega$  source, OUT1 and OUT2 LC matched to  $50\Omega$ ,  $T_A = +25^\circ C$ , unless otherwise noted.)

PARAMETER	SYMBOL	CONDITIONS	MIN	TYP	MAX	UNITS
Reverse Isolation (IN to OUT1)	$ S_{12} ^2$	$f_{IN} = 600MHz$		54		dB
		$f_{IN} = 900MHz$		49		
		$f_{IN} = 1900MHz$		34		
		$f_{IN} = 2400MHz$		30		
Noise Figure	NF	$f_{IN} = 900MHz$		9.5		dB
		$f_{IN} = 1900MHz$		10.2		
Isolation (OUT1 to OUT2)		$f_{IN} = 900MHz$		24		dB
Harmonic Suppression		$P_{OUT} = -5dBm$ , $f_{IN} = 900MHz$		-25		dBc

## AC ELECTRICAL CHARACTERISTICS—MAX2473

(Typical Operating Circuits,  $V_{CC} = +3V$ ,  $P_{IN} = -25dBm$ ,  $R_{BIAS} = 15k\Omega$ , IN driven from a  $50\Omega$  source, OUT LC matched to  $50\Omega$ ,  $T_A = +25^\circ C$ , unless otherwise noted.)

PARAMETER	SYMBOL	CONDITIONS	MIN	TYP	MAX	UNITS
Input Frequency Range (Note 2)	$f_{IN}$		500		2500	MHz
Transducer Gain	$ S_{21} ^2$	$f_{IN} = 600MHz$		14.8		dB
		$f_{IN} = 900MHz$ , $T_A = +25^\circ C$	6.8	11.8	16.8	
		$f_{IN} = 900MHz$ , $T_A = T_{MIN}$ to $T_{MAX}$ (Note 3)	6.4		19.0	
		$f_{IN} = 1900MHz$		7.6		
		$f_{IN} = 2400MHz$		7.2		
Output 1dB Compression Point	$P_{OUT1dB}$	$f_{IN} = 900MHz$	$R_{BIAS} = 23k\Omega$	-6.0		dBm
			$R_{BIAS} = 11k\Omega$	-0.9		
Reverse Isolation	$ S_{12} ^2$	$f_{IN} = 600MHz$		50		dB
		$f_{IN} = 900MHz$		48		
		$f_{IN} = 1900MHz$		35		
		$f_{IN} = 2400MHz$		29		
Noise Figure	NF	$f_{IN} = 900MHz$		9.2		dB
		$f_{IN} = 1900MHz$		9.9		
Harmonic Suppression		$P_{OUT} = -5dBm$ , $f_{IN} = 900MHz$		-25		dBc

**Note 1:** Limits are 100% production tested at  $T_A = +25^\circ C$ . Limits over the entire operating temperature range are guaranteed by design and characterization but are not production tested.

**Note 2:** This is the recommended operating frequency range. The parts have been characterized over the specified frequency range and production tested at 900MHz. Operation outside of this range is possible but not guaranteed.

**Note 3:** Guaranteed by design and characterization.

# 500MHz to 2500MHz VCO Buffer Amplifiers

## Typical Operating Characteristics

(MAX2472/MAX2473 EV kit,  $V_{CC} = +3V$ ,  $T_A = +25^{\circ}C$ , unless otherwise noted.)

### MAX2472

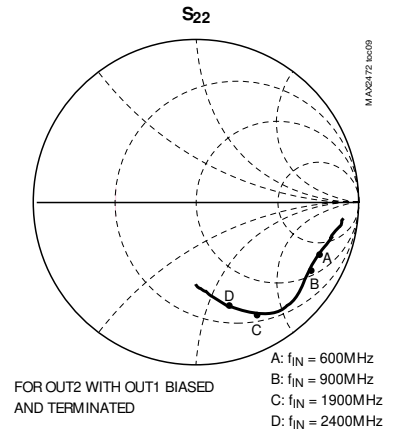
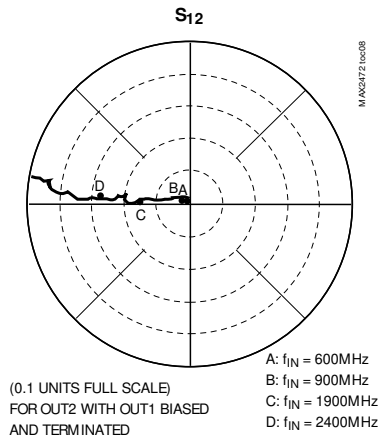
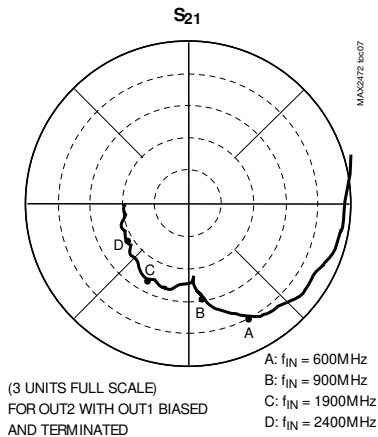
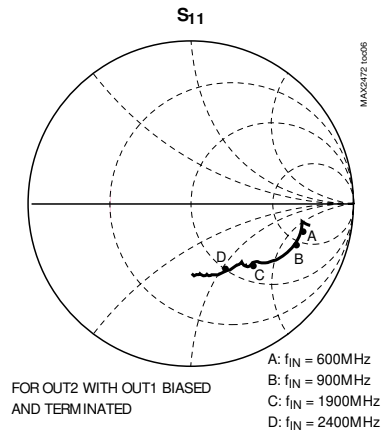
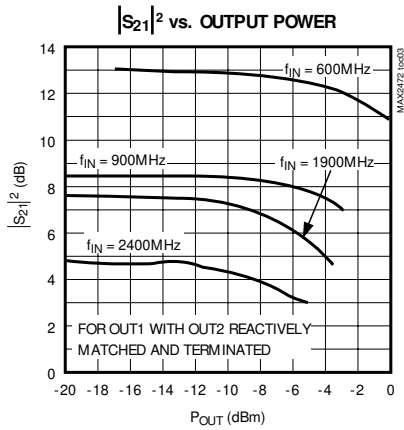
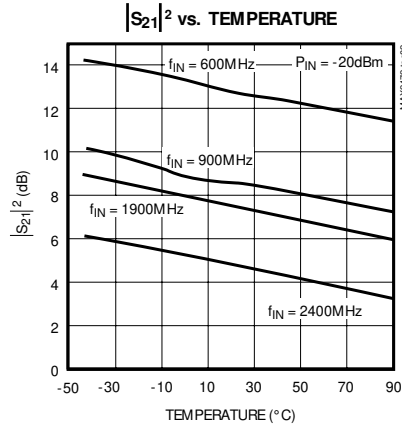
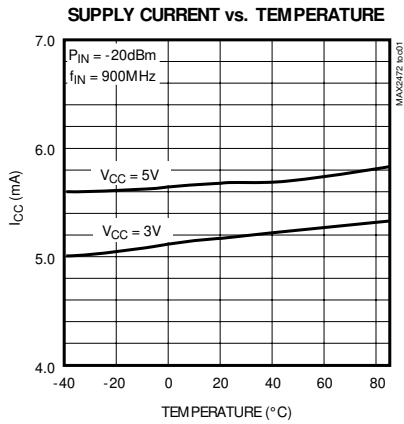

# 500MHz to 2500MHz VCO Buffer Amplifiers

## Typical Operating Characteristics (continued)

(MAX2472/MAX2473 EV kit,  $V_{CC} = +3V$ ,  $T_A = +25^{\circ}C$ , unless otherwise noted.)

### MAX2472 SCATTERING PARAMETERS (IN to OUT 2)

FREQ. (MHz)	S11	$\angle(S11)$	S21	$\angle(S21)$	S12	$\angle(S12)$	S22	$\angle(S22)$
100	0.752489	-9.9	3.213661	17.3	0.000787	95.1	0.91622	-6.0
200	0.695024	-8.2	2.867477	-14.6	0.00177	102.3	0.896396	-10.0
300	0.69024	-8.5	2.676086	-31.1	0.00278	93.4	0.867961	-13.3
400	0.693426	-9.4	2.606154	-43.3	0.003311	100.1	0.857038	-16.4
500	0.696627	-10.8	2.529298	-52.0	0.003802	98.0	0.840427	-18.9
600	0.697429	-13.7	2.385064	-61.0	0.004217	106.0	0.827942	-22.0
700	0.697429	-16.0	2.162719	-69.0	0.004624	114.0	0.817523	-24.5
800	0.691831	-18.9	1.961101	-77.0	0.004955	125.5	0.813767	-26.9
900	0.68786	-21.6	1.764006	-80.4	0.005821	137.5	0.810028	-29.4
1000	0.677642	-24.0	1.590377	-84.4	0.007104	136.6	0.812831	-32.0
1100	0.66604	-26.4	1.432188	-85.3	0.008091	149.3	0.817523	-34.6
1200	0.656145	-29.1	1.363013	-84.2	0.009627	157.2	0.827942	-37.0
1300	0.644169	-31.6	1.363013	-85.4	0.011495	163.5	0.837529	-40.4
1400	0.629506	-33.7	1.409289	-84.9	0.013884	167.5	0.843335	-43.9
1500	0.611646	-36.3	1.496236	-90.3	0.016982	169.6	0.844306	-47.5
1600	0.592243	-38.6	1.531087	-95.2	0.020893	173.0	0.838494	-52.0
1700	0.567545	-40.6	1.64059	-102.0	0.023988	172.1	0.82319	-55.6
1800	0.545758	-42.1	1.566751	-111.6	0.02729	172.4	0.801678	-58.9
1900	0.529663	-44.1	1.592209	-117.6	0.031189	173.4	0.776247	-61.6
2000	0.518203	-49.1	1.501412	-126.4	0.036433	179.5	0.749894	-64.3
2100	0.478079	-49.3	1.419058	-131.0	0.040644	171.7	0.729458	-66.2
2200	0.477529	-52.8	1.417425	-136.3	0.04431	172.6	0.707946	-68.5
2300	0.474788	-58.0	1.31674	-142.2	0.048473	177.1	0.685488	-70.4
2400	0.470977	-63.0	1.315225	-145.5	0.05559	176.2	0.663743	-72.7
2500	0.467197	-69.0	1.306171	-152.0	0.06166	176.0	0.64121	-75.0
2600	0.460787	-74.4	1.214787	-155.8	0.070795	176.5	0.61235	-77.6
2700	0.450817	-79.5	1.258925	-163.0	0.07709	173.9	0.584117	-80.7
2800	0.438531	-83.9	1.184404	-167.8	0.088308	172.3	0.552077	-83.6
2900	0.440555	-86.7	1.177606	-171.2	0.093004	170.0	0.530274	-86.7
3000	0.435512	-90.7	1.153453	-178.5	0.100462	169.4	0.500035	-91.0

MAX2472/MAX2473

# 500MHz to 2500MHz VCO Buffer Amplifiers

## Typical Operating Characteristics (continued)

(MAX2472/MAX2473 EV kit,  $V_{CC} = +3V$ ,  $T_A = +25^{\circ}C$ , unless otherwise noted.)

### MAX2473

SUPPLY CURRENT  
vs.  $R_{BIAS}$

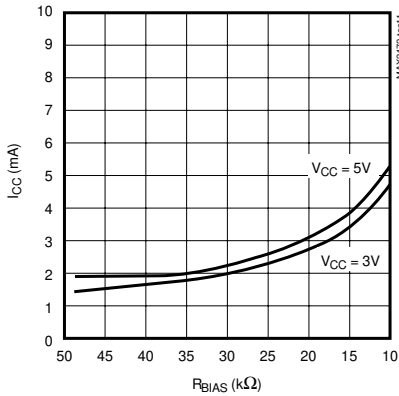

$|S_{21}|^2$  vs. TEMPERATURE

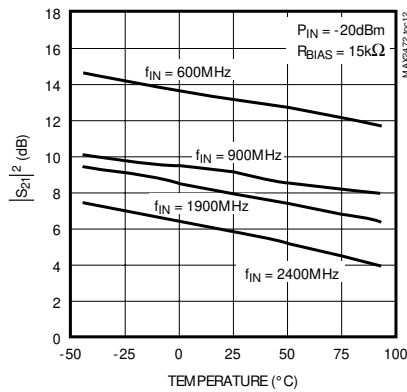

$|S_{21}|^2$  vs. OUTPUT POWER

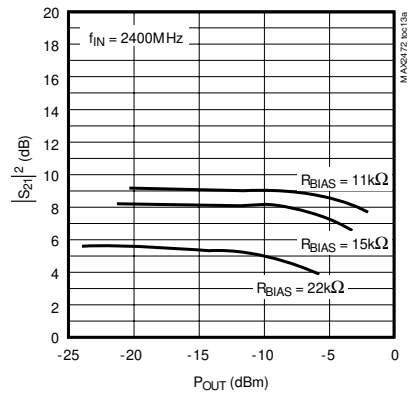

$|S_{21}|^2$  vs. OUTPUT POWER

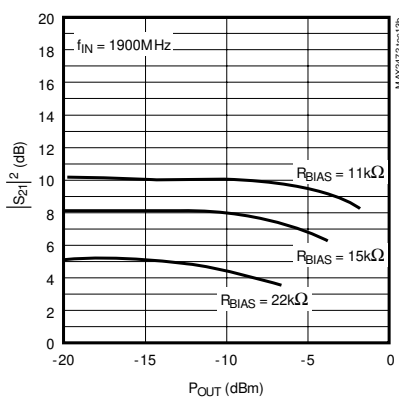

$|S_{21}|^2$  vs. OUTPUT POWER

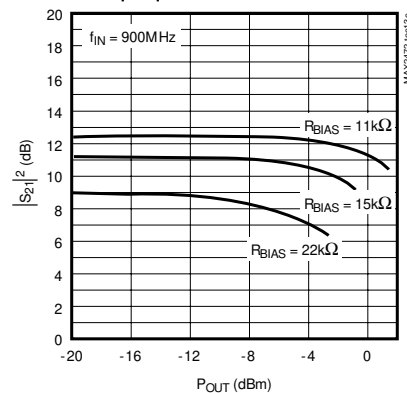

$|S_{21}|^2$  vs. OUTPUT POWER

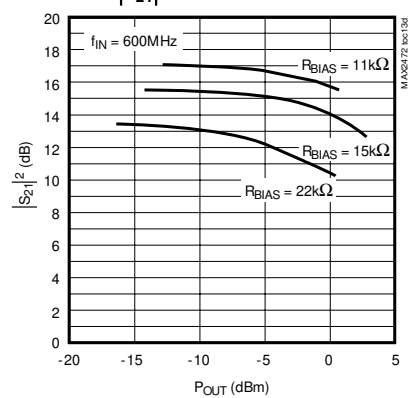

# 500MHz to 2500MHz VCO Buffer Amplifiers

## Typical Operating Characteristics (continued)

(MAX2472/MAX2473 EV kit,  $V_{CC} = +3V$ ,  $T_A = +25^{\circ}C$ , unless otherwise noted.)

MAX2472/MAX2473

### MAX2473

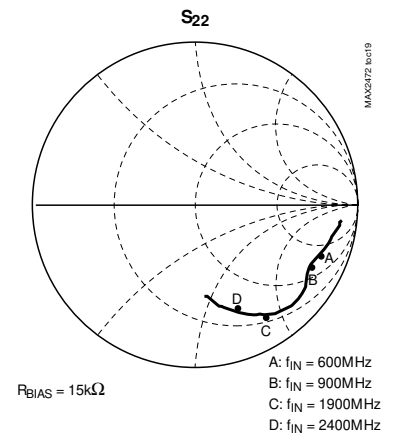
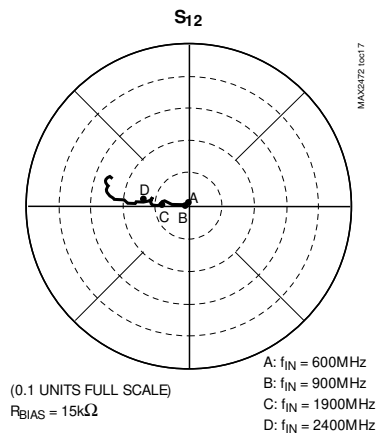
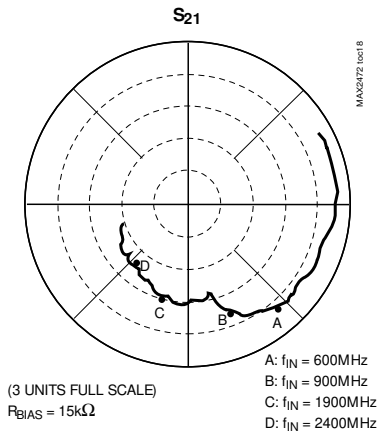
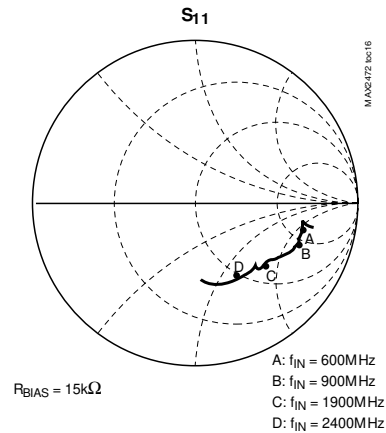
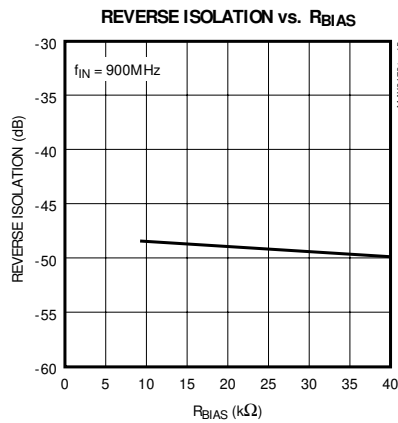

# 500MHz to 2500MHz VCO Buffer Amplifiers

## Typical Operating Characteristics (continued)

(MAX2472/MAX2473 EV kit,  $V_{CC} = +3V$ ,  $T_A = +25^\circ C$ , unless otherwise noted.)

### MAX2473 SCATTERING PARAMETERS (IN to OUT)

FREQ. (MHz)	IS11I	$\angle(S11)$	IS21I	$\angle(S21)$	IS12I	$\angle(S12)$	IS22I	$\angle(S22)$
100	0.770016	-10.0	2.497468	27.7	0.000252	44.80	0.998849	-5.9
200	0.712853	-9.1	2.676086	0.0	0.000694	94.17	0.894335	-9.6
300	0.699842	-9.0	2.570396	-17.0	0.001189	92.96	0.869961	-12.9
400	0.697429	-9.7	2.51478	-29.5	0.001256	104.40	0.859014	-16.0
500	0.696627	-11.0	2.443431	-39.0	0.001297	91.40	0.842364	-18.7
600	0.696627	-13.4	2.325412	-48.5	0.001341	105.00	0.827942	-21.8
700	0.697429	-15.6	2.162719	-57.0	0.001349	125.10	0.812831	-24.0
800	0.695825	-17.8	2.063004	-64.5	0.001641	140.00	0.805378	-26.1
900	0.694225	-20.1	1.879317	-69.7	0.002218	164.50	0.797995	-28.2
1000	0.688652	-22.2	1.735801	-75.1	0.003315	164.10	0.798914	-30.3
1100	0.678422	-24.7	1.575796	-77.9	0.004305	168.40	0.806306	-32.5
1200	0.671429	-26.7	1.491077	-78.3	0.005808	174.80	0.821297	-35.0
1300	0.659933	-28.5	1.470618	-80.6	0.007071	168.70	0.834642	-37.9
1400	0.645654	-30.5	1.480812	-80.9	0.008482	172.60	0.844306	-41.0
1500	0.6346	-32.4	1.529326	-86.0	0.009661	172.00	0.845279	-44.8
1600	0.623017	-34.2	1.518798	-90.5	0.01122	171.00	0.844306	-48.4
1700	0.606736	-36.4	1.590377	-96.0	0.012589	171.20	0.834642	-51.5
1800	0.595662	-38.6	1.51008	-103.6	0.013552	170.80	0.819408	-54.7
1900	0.587489	-41.2	1.529326	-108.2	0.015241	172.20	0.799834	-57.0
2000	0.578762	-45.3	1.44544	-116.3	0.01803	179.80	0.778037	-59.5
2100	0.553988	-46.8	1.377209	-119.6	0.020606	170.40	0.768245	-61.7
2200	0.550174	-50.1	1.391554	-124.5	0.021802	170.00	0.749031	-64.0
2300	0.54513	-55.0	1.298674	-130.4	0.023174	173.00	0.731139	-65.9
2400	0.54325	-60.1	1.294196	-133.0	0.026333	174.50	0.716143	-67.6
2500	0.539511	-64.5	1.294196	-139.5	0.029174	175.10	0.696627	-69.8
2600	0.532108	-70.0	1.198119	-143.0	0.034277	177.50	0.672202	-72.5
2700	0.525412	-75.6	1.258925	-150.0	0.038019	175.50	0.651628	-75.7
2800	0.517607	-80.7	1.16681	-154.7	0.045134	174.80	0.625893	-78.1
2900	0.514636	-84.1	1.162787	-158.4	0.047479	170.20	0.603949	-81.0
3000	0.504661	-88.3	1.135011	-166.9	0.052966	169.40	0.576103	-85.0



# 500MHz to 2500MHz VCO Buffer Amplifiers

MAX2472/MAX2473

## Pin Description

PIN		NAME	FUNCTION
MAX2472	MAX2473		
1	—	OUT1	Open-Collector Buffer Output 1. Connect to $V_{CC}$ via a resistor or inductor/choke. AC-coupling to the output is required.
—	1	OUT	Open-Collector Buffer Output. Connect to $V_{CC}$ via a resistor or inductor/choke. AC-coupling to the output is required.
2, 5	2, 5	GND	RF Ground. Connect to the ground plane as close to the IC as possible to minimize trace inductance.
3	—	OUT2	Open-Collector Buffer Output 2. Connect to $V_{CC}$ via a resistor or inductor/choke. AC-coupling to the output is required.
—	3	BIAS	Bias Resistor Connection. Connect a resistor from BIAS to GND to set the output stage bias current and gain. To choose $R_{BIAS}$ , refer to the <i>Typical Operating Characteristics</i> for the MAX2473.
4	4	IN	High-Impedance Input to the Buffer Amplifier
6	6	$V_{CC}$	Supply Voltage Input: $+2.7V < V_{CC} < +5.5V$

**Table 1. Output Matching Components**

OPERATING FREQUENCY (MHz)	L <sub>MATCH</sub>	C <sub>MATCH</sub>
600	22nH Coilcraft 0603HS-22NTJBC	1.5pF Murata GRM39COG1R5B50V
900	12nH Coilcraft 0603HS-12NTJBC	1pF Murata GRM39COG1R0B50V
1900	2.2nH Murata LQG11AZN2500	1pF Murata GRM39COG1R0B50V
2400	1.2nH Murata LQG11AINZS00	1pF Murata GRM39COG1R0B50V

## Detailed Description

The MAX2472/MAX2473 are ideal replacements for discrete solutions where a VCO output must drive more than one input, especially where high reverse isolation and low supply currents are mandatory. The MAX2472 features a two-stage wideband architecture with a high-input-impedance common-emitter amplifier followed by

two separate open-collector output stages. The MAX2473 features a two-stage wideband architecture with a high-input-impedance common-emitter amplifier followed by one open-collector output stage, with the added feature of output power control. Using values for  $R_{BIAS}$  from 11k $\Omega$  to 23k $\Omega$  allows the output power of the MAX2473 to range from -2dBm to -10dBm.

# 500MHz to 2500MHz VCO Buffer Amplifiers

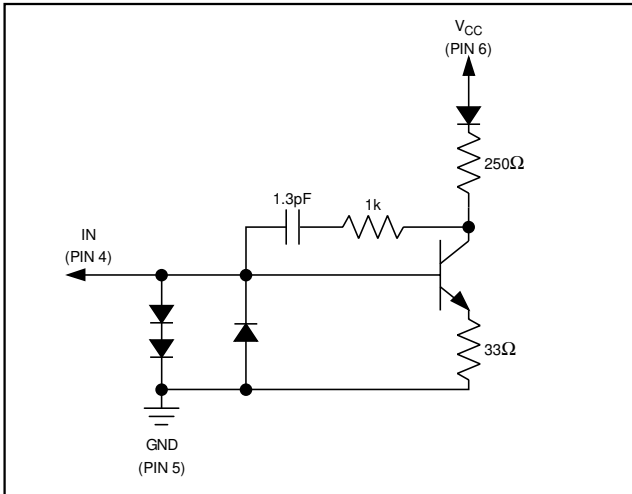

Figure 1. Input Structure

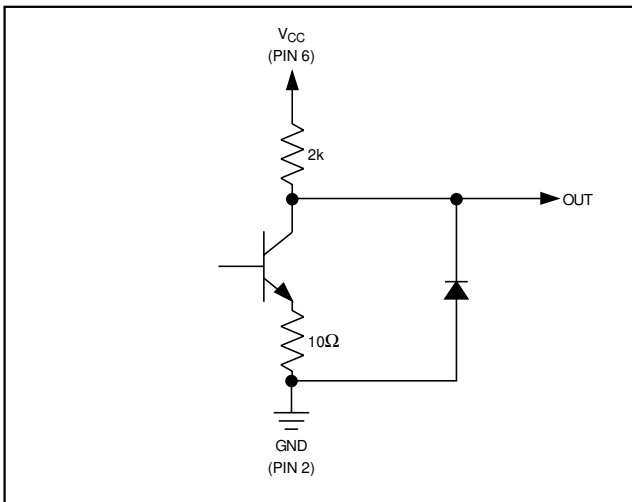

Figure 2. Output Structure

## Applications Information

### Input Considerations

The MAX2472/MAX2473 offer high-impedance inputs ideal for low-distortion buffering of a VCO. For applications with discrete transistor-based oscillator designs, simply AC-couple the oscillator directly to the input; the buffer's high input impedance results in minimal loading on the oscillator. For use with 50Ω VCO modules, determine the approximate input impedance ( $S_{11}$ ) of

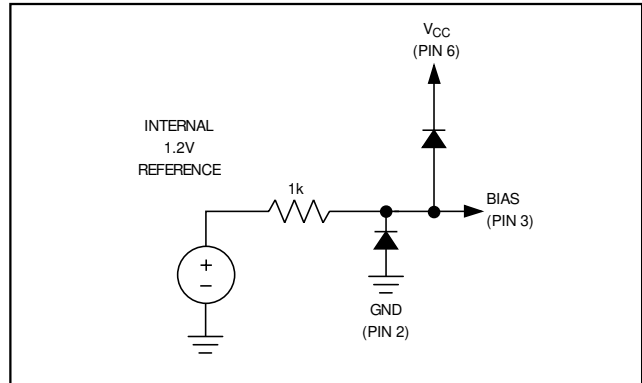

Figure 3. BIAS Structure (MAX2473 only)

the MAX2472/MAX2473 from the S parameter tables in the *Typical Operating Characteristics*. Terminate the buffer input with a shunt resistor "RTERM" such that  $R_{TERM} \parallel RE[S_{11}] = 50\Omega$ , and use a series blocking capacitor between the shunt resistor and the device input. This provides a very stable 50Ω termination and increases reverse isolation. For those applications needing both high gain and good input match, reactively match the buffer inputs to 50Ω with simple two-element matching circuits. Figure 1 shows an equivalent input circuit of the MAX2472/MAX2473 IN pin.

### Output Considerations

The MAX2472/MAX2473 outputs are configured as open-collector output stages, allowing maximum flexibility. To achieve maximum gain and output drive, reactively match these outputs with a shunt inductor/choke to  $V_{CC}$  followed by a series capacitor (DC block). For applications not requiring high gain and output drive (PLL prescaler), use a simple resistor to  $V_{CC}$  followed by a DC blocking capacitor. Figure 2 shows an equivalent circuit of the MAX2472/MAX2473 OUT pin(s). Figure 3 shows an equivalent circuit of the MAX2473 BIAS pin.

### Output Matching Circuit

Table 1 lists recommended values for lumped-element output matching circuits at certain frequencies. For frequencies other than those specified, use the parameters given in the *Typical Operating Characteristics*.

### Layout and Power-Supply Bypassing

A properly designed PC board is essential to any RF/microwave circuit. Be sure to use controlled impedance lines on all high-frequency inputs and outputs. Bypass the power supply with decoupling capacitors

# 500MHz to 2500MHz VCO Buffer Amplifiers

as close to the VCC pin as possible. For long VCC lines (inductive), it may be necessary to add additional decoupling capacitors located farther away from the device package.

Proper connection of the GND pins is essential to achieving maximum reverse isolation. If the PC board

uses a topside RF ground, connect both GND pins directly to it. For a board where the ground plane is not on the component side, the best technique is to connect the GND pins to the board with plated through-holes (vias) to the ground plane, located as close to the package as possible.

MAX2472/MAX2473

## Typical Operating Circuits

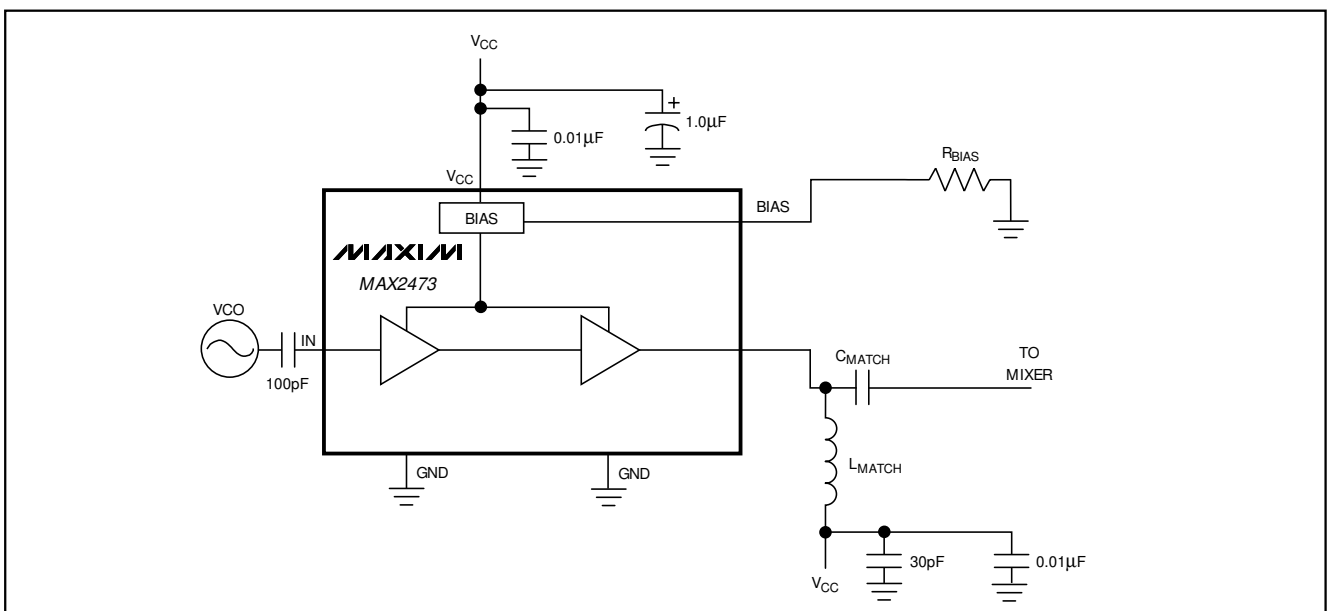
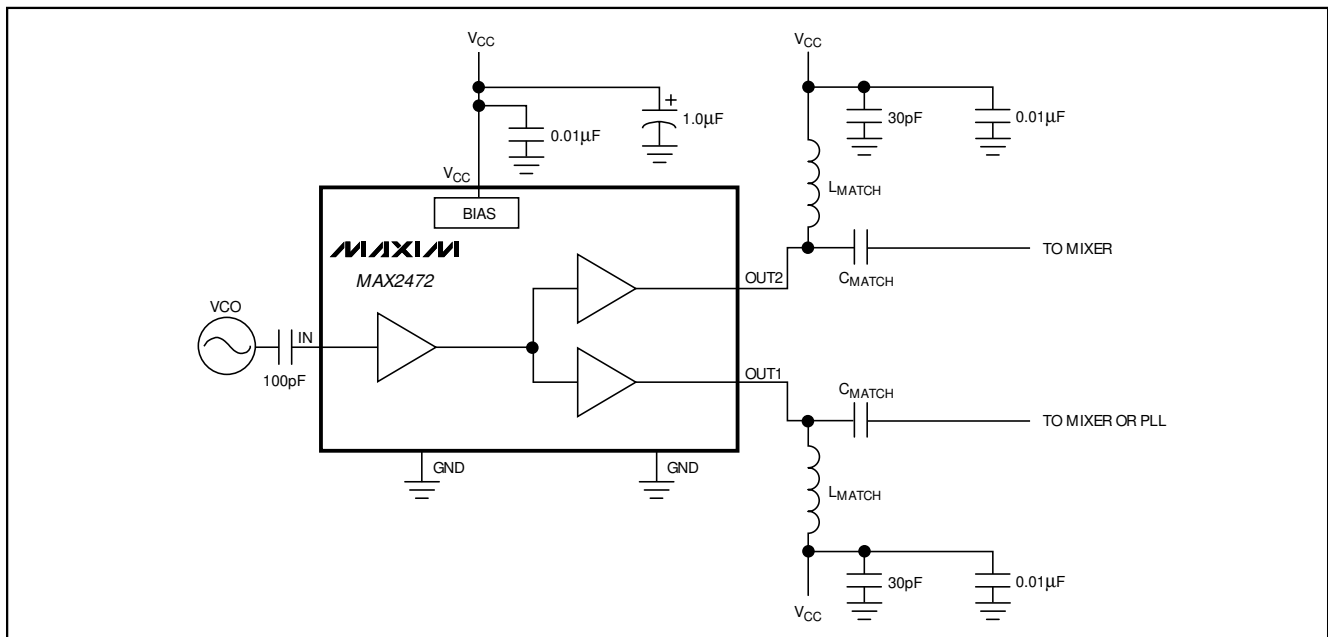

# 500MHz to 2500MHz VCO Buffer Amplifiers

## Package Information

6LSOT.EPS

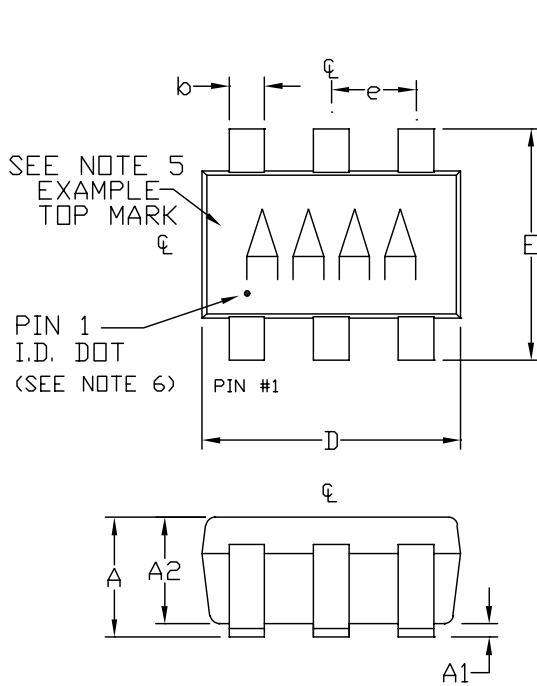

SYMBOL	MIN	MAX
A	0.90	1.45
A1	0.00	0.15
A2	0.90	1.30
b	0.35	0.50
C	0.08	0.20
D	2.80	3.00
E	2.60	3.00
E1	1.50	1.75
L	0.35	0.55
e	0.95 REF	
alpha	0°	10°

NOTE:

1. ALL DIMENSIONS ARE IN MILLIMETERS.
2. FOOT LENGTH MEASURED AT INTERCEPT POINT BETWEEN DATUM A & LEAD SURFACE.
3. PACKAGE OUTLINE EXCLUSIVE OF MOLD FLASH & METAL BURR.
4. PACKAGE OUTLINE INCLUSIVE OF SOLDER PLATING.
5. PIN 1 IS LOWER LEFT PIN WHEN READING TOP MARK FROM LEFT TO RIGHT. (SEE EXAMPLE TOP MARK)
6. PIN 1 I.D. DOT IS 0.3 MM Ø MIN. LOCATED ABOVE PIN 1.

<b>MAXIM</b>			
<small>PROPRIETARY INFORMATION</small>			
<small>TITLE:</small>			
PACKAGE OUTLINE, SOT23, 6L			
<small>APPROVAL</small>	<small>DOCUMENT CONTROL NO.</small>	<small>REV</small>	<small>1/1</small>
	21-0058	D	

## Chip Information

TRANSISTOR COUNT: 109