

THIS IS A C.A.D. GENERATED DRAWING
DO NOT MAKE MANUAL REVISIONS TO MASTER.

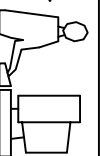

ISSUE NUMBER
ORIGINAL

①

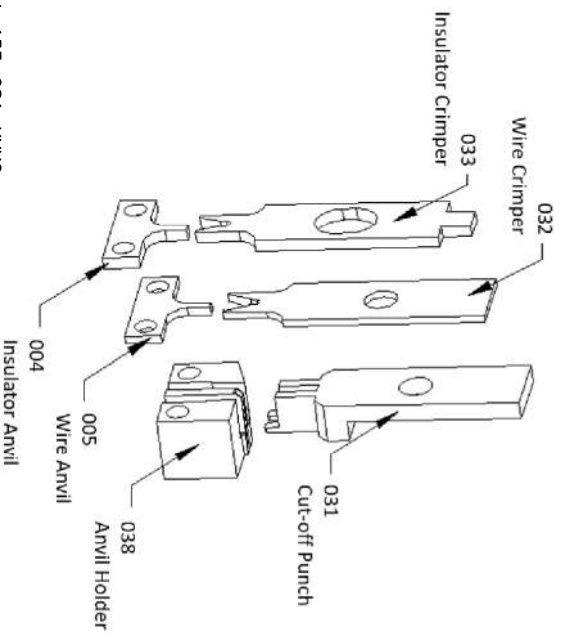
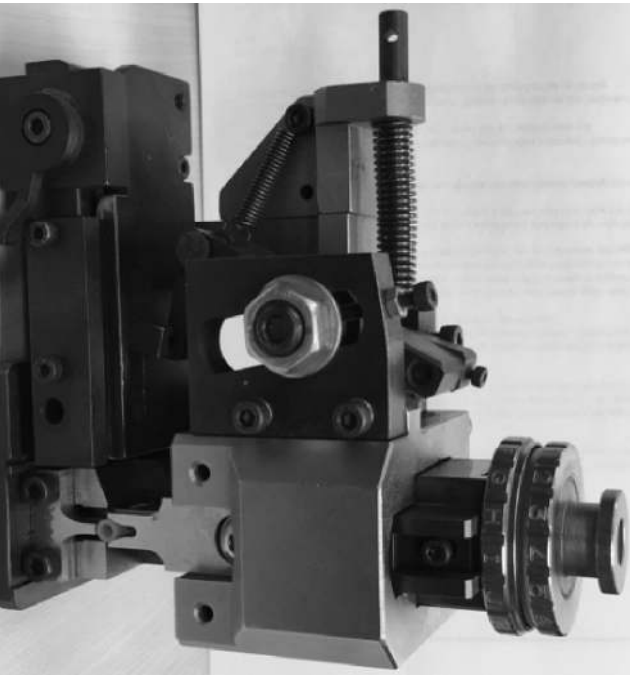

P/N: 153-281-XXXX

PRESS TYPE	G PRESS
STROKE LENGTH	40.00 MM
SHUT HEIGHT	135.79 MM
AWG	22-26

REPLACEMENT PUNCH & DIE PARTS					
INSULATOR ANVIL	WIRE ANVIL	WIRE CRIMPER	INSULATOR CRIMPER	CUT OFF PUNCH	ANVIL HOLDER
153-281-004G	153-281-005G	153-281-032G	153-281-033G	153-281-031G	153-281-038G

NOTES:

- 1- THIS APPLICATOR IS DESIGNED TO BE USED ON A G CRIMPING MACHINE.
- 2- THIS APPLICATOR IS DESIGNED FOR CRIMPING EDAC CONTACT P/N 153-290-291.
- 3- FOR THE DEFINITION OF STROKE LENGTH AND SHUT HEIGHT, APPLICATOR SETUP AND OPERATING INSTRUCTION, PLEASE REFER TO DOCUMENT "APPLICATOR INSTRUCTION MANUAL G PRESS".

153 SERIES APPLICATOR FOR G PRESS

 <p>EDAC INC TORONTO, ONTARIO CANADA</p>		<p>YOUR CONNECTION TO QUALITY & SERVICE</p>	
<p>THESE DRAWINGS AND SPECIFICATIONS ARE THE PROPERTY OF EDAC INC. AND SHALL NOT BE REPRODUCED, OR COPIED OR USED AS THE BASIS FOR THE MANUFACTURE OR SALE OF APPARATUS WITHOUT WRITTEN PERMISSION.</p>			
ACAD REFERENCE NO. 153-280-750G		DATE: OCT.30/2020	
DRAWN: K.L.		DATE: OCT.30/2020	
CHECKED: R.S.M.		SHEET 1 OF 1	
SCALE: N.T.S.		DRAWING NUMBER 153-280-750G	
DRAWING NUMBER 153-280-750G		ISSUE 1	