

4

3

2

1

THIS DRAWING IS UNPUBLISHED.

RELEASED FOR PUBLICATION

© COPYRIGHT

ALL RIGHTS RESERVED.

LOC DIST

REVISIONS

P	LTR	DESCRIPTION	DATE	DWN	APVD
	A1	ECR-16-011294	06AUG2016	GK	SD

REPLACED BY OCEAN STYLE APPLICATOR PART NUMBER 2836345-1

FOR REPLACEMENT PARTS FOR APPLICATOR 1528750
REFER TO ADDITIONAL PAGE(S). SPARE PARTS KIT (IF LISTED)
WILL REMAIN AVAILABLE.

THE REPLACEMENT OCEAN STYLE APPLICATOR HAS THE
SAME TERMINATOR/PRESS INTERFACE AS APPLICATOR
1528750

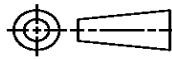
THIS DRAWING IS A CONTROLLED DOCUMENT.		DWN	GOPALAKRISHNA HV		
DIMENSIONS:		CHK	GOPALAKRISHNA HV		
		TOLERANCES UNLESS OTHERWISE SPECIFIED:		APVD	
		0 PLC ± 1 PLC ± 2 PLC ± 3 PLC ± 4 PLC ± ANGLES ±		STOUGH DALE	
MATERIAL		FINISH		NAME	
				FINE ADJUST SIDE FEED HDI APPLICATOR	
		WEIGHT		SIZE	RESTRICTED TO
				A3	
		CUSTOMER DRAWING		DRAWING NO	
				CAGE CODE	
				SCALE	
				DRAWING NO	
				SCALE	
				SHEET	
				1 OF 2	
				REV	
				A1	

PART NUMBER	REV	TERMINATOR	FEED TYPE	DESCRIPTION
1528750-1	A	LEADMAKER	MECH POST FEED	CUTS CARRIER
1528750-2	A	BENCH	MECH PRE FEED	CUTS CARRIER
1528750-6	A	LEADMAKER	MECH POST FEED	CONTINUOUS CARRIER
7-1528750-1	A	LEADMAKER	MECH POST FEED	-1 AND SPARE PARTS
7-1528750-2	A	BENCH	MECH PRE FEED	-2 AND SPARE PARTS
7-1528750-6	A	LEADMAKER	MECH POST FEED	-6 AND SPARE PARTS
7-1528750-7	A	-	-	SPARE PARTS KIT

CRIMP DATA		TYCO TERMINAL		TYCO CRIMP SPECS	
TERMINAL NAME: CRIMP CONTACT ELO					
CRIMP	SIZE	TYPE	RANGE		
WIRE	1.40 [.055 IN]	F	0.35mm ² -0.50mm ²		
INSUL	3.05 [.120 IN]	O	2.60 [.102 IN]		
WIRE STRIP LENGTH		APPL INSTRUCTIONS			
3.70-3.90 [.146-.154 IN]		408-8322 & 408-8490			
TERMINAL APPL SPEC		114-18432		FEED 10.16 [.400 IN]	
TERMINALS APPLIED					
TERM PN	-	SEAL PN	-		
1411554	-	1393457-1	-		
1411556	-	1393457-2	-		
1411572	-	-	-		
1411578	-	-	-		
WIRE SIZE	CRIMP HEIGHT	REF SETTING			
0.50mm ²	1.00 ± 0.03 [.039 ± .001 IN]	B3			
0.35mm ²	0.92 ± 0.03 [.036 ± .001 IN]	B9			

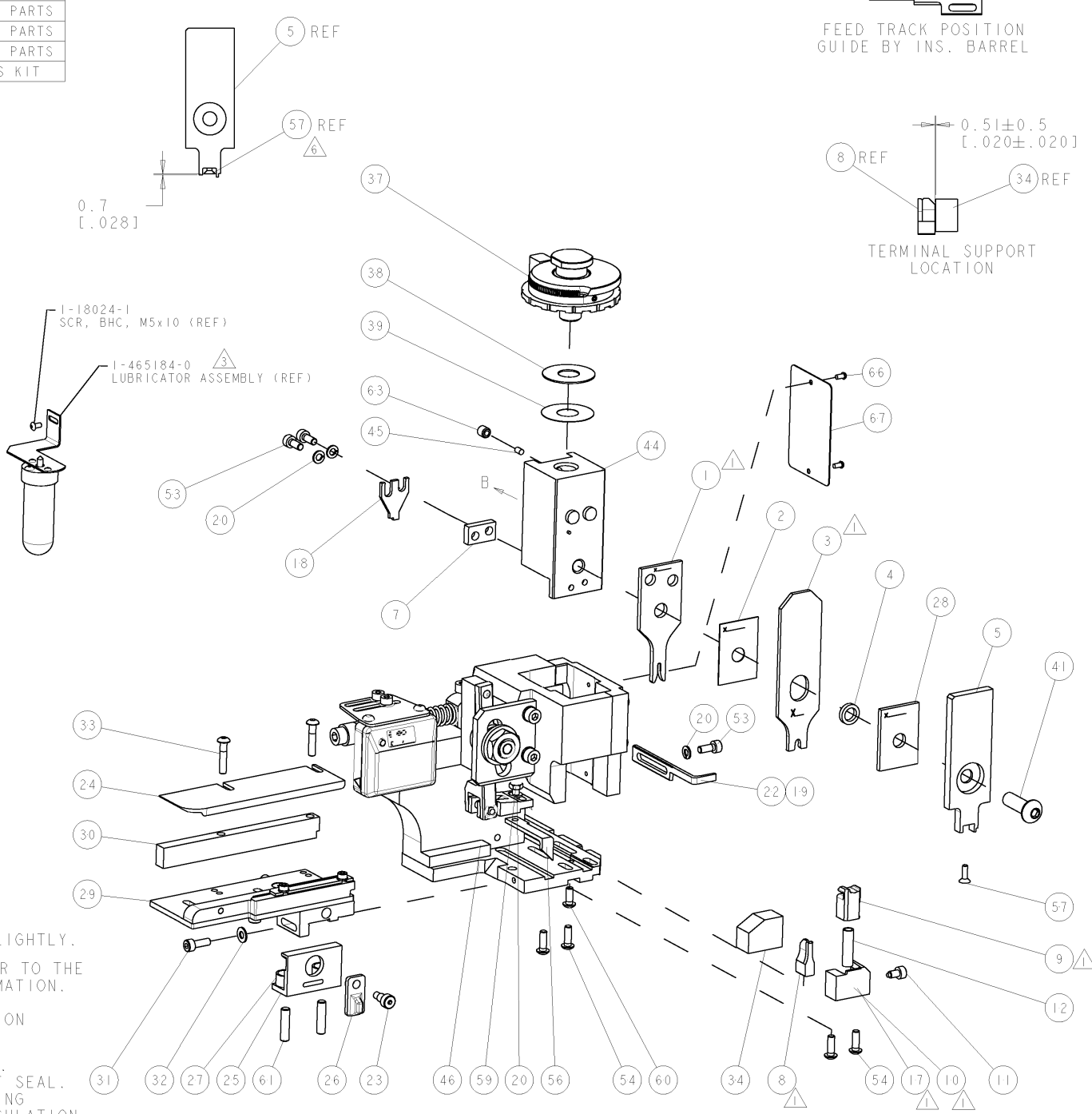

- RECOMMENDED SPARE PARTS.
- GREASE RAM, CAM, CAM FOLLOWER AND FEED ROD LIGHTLY.
- CERTAIN TERMINALS REQUIRE LUBRICATION. REFER TO THE APPLICATOR INSTRUCTION SHEET FOR MORE INFORMATION.
- LUBRICATE DAILY PER THE APPLICATOR INSTRUCTION SHEET SUPPLIED WITH THE APPLICATOR.
- THIS APPLICATOR APPLIES TERMINAL WITH A SEAL. INSULATION DIA QUOTED IS OUTSIDE DIAMETER OF SEAL. WIRE INSULATION DIA IS DEPENDENT ON SEAL BEING APPLIED. SEE CUSTOMER DRAWINGS FOR SEAL INSULATION RANGES AND FOR TERMINAL TO SEAL COMPATIBILITY.
- APPLY TORQ-SEAL IN ALLEN SOCKET TO FILL HOLE AFTER FLAT HD HAS BEEN ADJUSTED TO CORRECT HEIGHT AT QUALIFICATION. APPLY #1-23419-5 LOC-TITE TO THREADS.

*** WARNING**
ON INSTALLATION, SET WIRE DISC TO LARGEST WIRE SIZE SETTING. USE OF SETTINGS BELOW MIN. REQUIRED CRIMP HEIGHT SETTING WILL CAUSE DAMAGE TO CRIMP TOOLING.

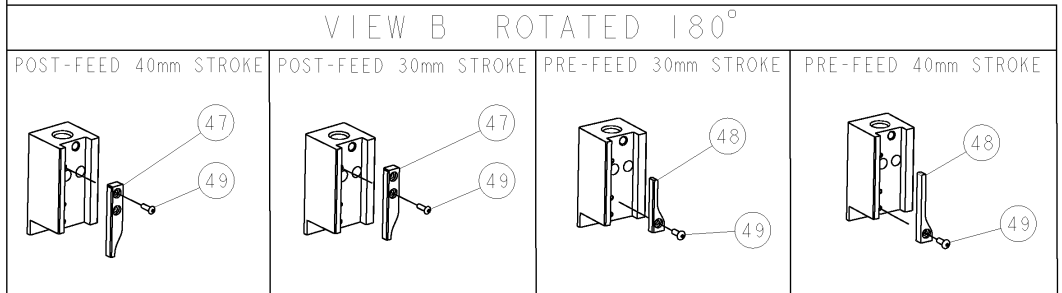

ITEM NO	DESCRIPTION	ITEM NO
84		
83		
82		
81		
80		
79		
78		
77		
76		
75		
74		
-77 -76 -72 -71 -6 -2 -1	PART NO	DESCRIPTION

REV	DESCRIPTION	DATE	BY	APPV
A	SEE ECO-07-003391	12FEB2007	DP	MC

ITEM NO	DESCRIPTION	ITEM NO
73		
72		
71	DOCUMENTATION PACKAGE	
70		
69		
68		
67	PLATE, IDENTIFICATION	
66	SCREW, DRIVE	
65		
64		
63	SCR, SET, CUP POINT M6 X 6.0	
62		
61	SCR, SET, FLT POINT M5 X 20.0	
60	SCR, BTN SKT HD CAP (M4 X 10.0)	
59	SCR, HEX HD CAP M4 X 8.0	
58		
57	SCR, FLT SKT HD CAP M3 X 10.0	
56	PAWL, FEED	
55		
54	SCR, BTN SKT HD CAP (M4 X 12.0)	
53	SCR, SKT HD CAP M4 X 10.0	
52		
51		
50		
49	SCR, BTN SKT HD CAP (M3 X 10.0)	
48	CAM, UNIVERSAL PRE FEED	
47	CAM, UNIVERSAL POST-FEED	
46	APPLICATOR SUBASSEMBLY, HDI	
45	PLUG, NYLON	
44	RAM	
43		
42		
41	SCR, BTN SKT HD CAP (M8 X 25.0)	
40		
39	SHIM SUB-ASSY	
38	SHIM	
37	FINE ADJUST HEAD ASSEMBLY	
36		
35		
34	SUPPORT, TERMINAL	
33	SCR, BTN SKT HD CAP (M4 X 20.0)	
32	WASHER, FLAT, REG M4	
31	SCR, SKT HD CAP M4 X 12.0	
30	SPACER, STRIP GUIDE	
29	STRIP GUIDE ASSEMBLY	
28	SPACER, CRIMPER	
27	SPRING, COMPRESSION	
26	LEVER, DRAG RELEASE	
25	DRAG, TERMINAL	
24	PLATE, STRIP GUIDE	
23	SCR, SKT HD SHLDR 5.0 DIA X 6.0	
22	STRIPPER	
21	SCR, SKT HD CAP M4 X 10.0	
20	WASHER, SPRG LOCK, REG M4	
19	STRIPPER	
18	HOLD DOWN	
17	SHEAR HOLDER, FRONT	
16		
15		
14		
13		
12	SPRING, COMPRESSION	
11	STOP, SHEAR	
10	SHEAR HOLDER, FRONT, CUT	
9	FLOATING SHEAR, FRONT	
8	ANVIL, COMBINATION	
7	SPACER	
6		
5	DEPRESSOR, SHEAR	
4	BLOCK, CRIMPER SPACER	
3	CRIMPER, INSULATION	
2	SPACER, CRIMPER	
1	CRIMPER, WIRE PREMIUM	

TYCO ELECTRONICS CORPORATION, HARRISBURG, PA 17105-3608

APPROVED: M. CLIFFORD, 10 JAN 2007

NAME: FINE ADJUST SIDE FEED HDI APPLICATOR

SIZE: CARE CODE: DRAWING NO: 1528750

SCALE: 3:5 SHEET 1 OF 1 REV A