

TMX-350



Featuring:

- Diode isolated outputs for hot swap
- “Zero wire” slope program current sharing
- Self-aligning connector with solid metal, machined contacts
- Identical output performance as RMX-350 Series
- Dual converter design eliminates interaction between logic and auxiliary outputs
- Low ripple and noise on all outputs
- DC power good signal
- True remote inhibit
- Monotonic turn-on and turn-off

STANDARD TMX SERIES

MODEL	PWR	OUTPUT #1	OUTPUT #2	OUTPUT #3	OUTPUT #4
TMX-353-0512	350	+5V @ 50A	+12V @ 8/12A pk	-12V @ 4A	
TMX-354-1205	350	+5V @ 50A	+12V @ 8/12A pk	-12V @ 4A	5.2V @ 5A
TMX-354-1212	350	+5V @ 50A	+12V @ 8/12A pk	-12V @ 4A	12V @ 5A
TMX-354-1224	350	+5V @ 50A	+12V @ 8/12A pk	-12V @ 4A	24V @ 3A
TMX-354-1512	350	+5V @ 50A	+15V @ 4A	-15V @ 4A	12V @ 5A
TMX-354-1524	350	+5V @ 50A	+15V @ 4A	-15V @ 4A	24V @ 3A

Maximum power from outputs #2, #3 and #4 to be less than 170W

TMX Series power supplies are designed to meet applicable Bellcore and NEBS standards, so they are readily operated from Central Office power (48 Vdc). They are DC clones of Condor's RMX Series power supplies. The RMX and TMX power supplies are directly interchangeable. They allow you to operate existing systems from AC or DC power without compromising performance or making any mechanical changes for mounting or cooling.

TMX and RMX Series power supplies can also be operated in redundant configurations to achieve AC operation with battery backup capability.

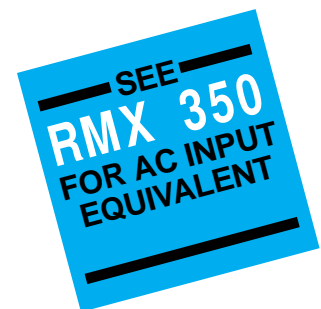

350 WATTS
10.75" x 4.8" x 2.5"
TMX-350

TMX-350
3.8 lbs - 1.7 kgs

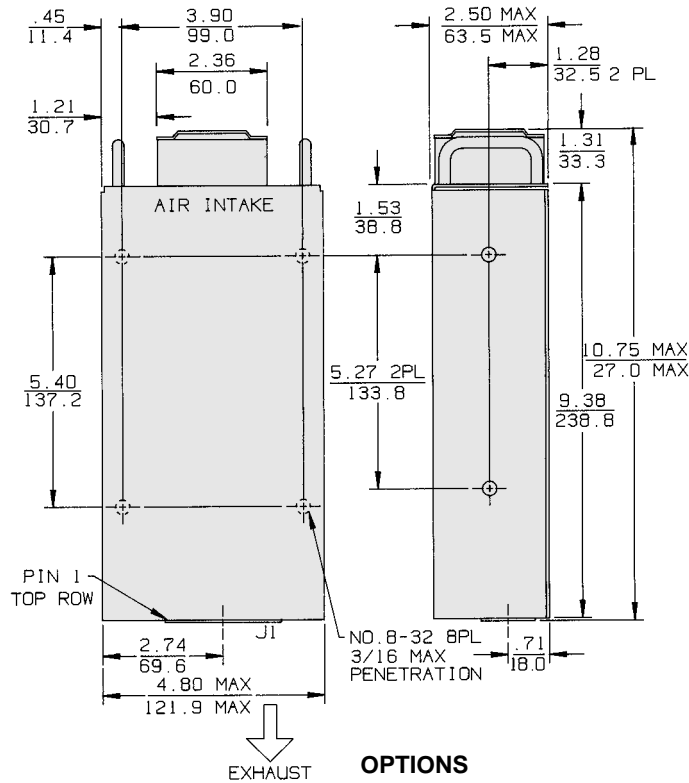

SPECIFICATIONS: ALL MODELS

INPUT

DC Input: 40-60 Vdc. Internally fused for 15 A.
Efficiency: 75% typical.
Low Input Provides TTL "0" when input is below 40 Vdc.

OUTPUT

Adjustability: Outputs #1 and 2, and 4 factory adjusted to nominal $\pm 0.2\%$. Output #3 tracks #2; initial accuracy $\pm 3\%$.
Line & Load Reg: Outputs #1, 2, and 4 hold $\pm 2\%$ (with local sense) over dc input range and 0 to 100% load change (preprogrammed slope). Output #3 requires 20% minimum load on outputs #2 and 3 to hold $\pm 5\%$.
Ripple & Noise: 1% p-p or 100 mV, whichever is greater.
Remote Sense (Output #1): Compensates for 250 mV total line drop. Preprogrammed slope remains under $\pm 3\%$ worst case. Open sense lead protection.
Temperature Coefficient (Outputs #1, 2, and 4): 0.03% per degree C.
Stability: 0.1% over 8 hours after 30 minutes warm-up.
Transient Response (Outputs #1, 2, and 4): Output voltage returns to within 1% in less than 500 μ s for a 50% load change (measured with rise time and fall time of 200 μ s). Peak transient does not exceed 5%.
Overload Protection: All outputs are protected against overload and short circuit. Automatic recovery upon removal of fault.
Overvoltage Protection (Outputs #1 and 2): Protects load against power supply induced over-voltage. Trip point is factory set so that output voltage cannot exceed 136% of nominal.
Peak Output Current: Dual current ratings define continuous and peak currents. The peak current shown can be delivered for a maximum period of 30 seconds.
Remote Inhibit: Contact closure to the negative sense line or a TTL level "0" turns off DC outputs.
Redundancy: Built-in OR-ing diodes, slope program current sharing on all outputs, and self aligning connector provide "hot swap" and "N+1" capabilities. Current sharing remains within 10% of the unit's full output rating while units are in thermal equilibrium.
Remote Enable: Contact closure to common turns on DC outputs (recessed pin for "make last, break first" connection).
DC Power Good: Provides a TTL "1" open collector when output #1 is above 4.6 V nominal.
Reverse Voltage: Protected against reverse voltage up to supply current rating.

ENVIRONMENTAL

Thermal Protection: Shuts down power supply if overheated. Automatic recovery.
Holdup Time: 20 ms minimum after removal of power at full load.
Temperature Range: 0° to 50°C at full ratings.
Safety Agencies: Most models are approved to UL1950; CSA 22.2 #234; IEC 950 and TÜV EN60950, Class 1 SELV, CE 72/23/EEC/93/68EEC (low voltage directive).
Conducted RFI: Meets FCC Part 15, Subpart J, Class A; EN55022 Class B and CISPR 22 Class B.
Cooling: Self-cooled by internal ball-bearing fan.
Output Isolation: Isolated from ground 50 Vdc.

OPTIONS

Consult factory for available options.

DC INPUT

FUNCTION	48 Vdc	CONNECTOR
J1-22	+48 Vdc	See below
J1-24	-48 Vdc	
J1-11	Safety Ground	

DC OUTPUT

FUNCTION	LOCATION	NOTES	CONNECTOR
Output #1	J1- 10, 20, 30	Main Output	Positronics # PLC30M400A1-168.3 Mates with panel mounted PLC30F1000 connector using crimp contacts FC114N2 (14 to 16 AWG)
	J1- 9, 19, 29	Rtn (Common)	
Output #2	J1-2		
	J1-3	Rtn (Common)	
Output #3	J1-4		
	J1-3	Rtn (Common)	
Output #4	J1-5	(+) Floating Output	
	J1-6	(-) Floating Output	

STATUS AND CONTROL

FUNCTION	LOCATION	NOTES	CONNECTOR
Remote Sense	J1-18	Output #1 Sense	See above
	J1-8	Output #1 Sense Rtn	
DC Power Good	J1-7	Reference to Common when #1 Sense Rtn is terminated	
		Reference to Common	
Enable	J1-16		
Inhibit	J1-27		
Battery Low	J1-17		