

1A, 1.5MHz, 5.5V CMCOT Synchronous Step-Down Converter

Purpose

The RT5710C is a synchronous step-down converter with the input voltage range from 2.5V to 5.5V and provides 1A output current. This document explains the function and use of the RT5710C evaluation board (EVB), and provides information to enable operation, modification of the evaluation board and circuit to suit individual requirements.

Table of Contents

Purpose	1
Introduction.....	2
Key Performance Summary Table	2
Bench Test Setup Conditions	3
Schematic, Bill of Materials & Board Layout	4
More Information.....	7
Important Notice for Richtek Evaluation Board	7

Introduction

General Product Information

The RT5710C is a high efficiency synchronous step-down DC/DC converter. Its input voltage range is from 2.5V to 5.5V and provides an adjustable regulated output voltage from 0.6V to 3.4V while delivering up to 1A of output current. The internal synchronous low on-resistance power switches increase efficiency and eliminate the need for an external Schottky diode. The Current Mode Constant-On-time (CMCOT) operation with internal compensation allows the transient response to be optimized over a wide range of loads and output capacitors.

Product Feature

- Efficiency Up to 95%
- $R_{DS(ON)}$ 160m Ω HS / 110m Ω LS
- V_{IN} Range 2.5V to 5.5V
- V_{REF} 0.6V with $\pm 2\%$ Accuracy
- CMCOT™ Control Loop Design for Best Transient Response, Robust Loop Stability with Low-ESR(MLCC) C_{OUT}
- Fixed Soft-Start 1.2ms
- Cycle-by-Cycle Over Current Protection
- Input Under Voltage Lockout
- Output Under Voltage Protection (UVP Hiccup)
- Thermal Shutdown Protection
- Power Saving at Light Load

Key Performance Summary Table

Key Features	Evaluation Board Number : PCB034_V1
Default Input Voltage	3.3V
Max Output Current	1A
Default Output Voltage	1.2V
Default Marking & Package Type	RT5710CHGQW, WDFN-6L 2x2
Operation Frequency	Fixed 1.5MHz

Bench Test Setup Conditions

Headers Description and Placement

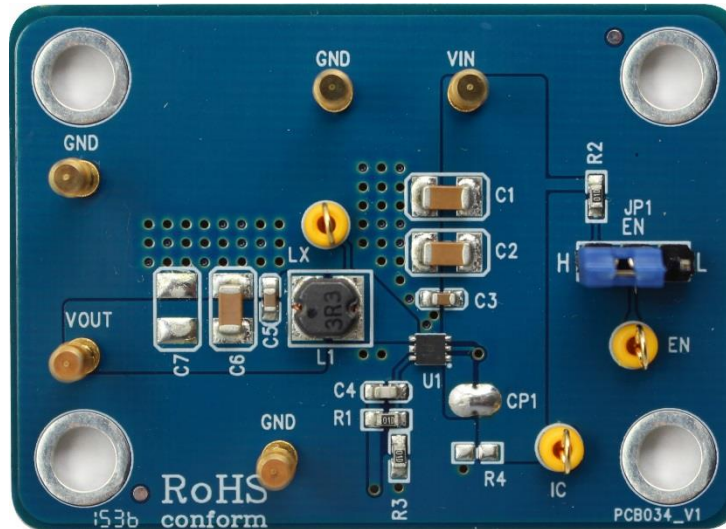

Please carefully inspect the EVB IC and external components, comparing them to the following Bill of Materials, to ensure that all components are installed and undamaged. If any components are missing or damaged during transportation, please contact the distributor or send e-mail to evb_service@richtek.com

Test Points

The EVB is provided with the test points and pin names listed in the table below.

Test point/Pin name	Signal	Comment (expected waveforms or voltage levels on test points)
VIN	Input voltage	Supply Voltage Input.
EN	Enable test point	Enable control input.
GND	Ground	Ground. The exposed pad must be soldered to a large PCB and connected to GND for maximum thermal dissipation.
IC	No internal connection	
FB	Feedback	
LX	Switch node test point	Switch node.

Power-up & Measurement Procedure

1. Apply a 3.3V nominal input power supply ($2.5V < V_{IN} < 5.5V$) to the VIN and GND terminals.
2. Set the jumper at JP1 to connect terminals 2 and 3, connecting EN to enable operation.
3. Verify the output voltage (approximately 1.2V) between VOUT and GND.
4. Connect an external load up to 1A to the VOUT and GND terminals and verify the output voltage and current.

Output Voltage Setting

Set the output voltage with the resistive divider (R2, R3) between VOUT and GND with the midpoint connected to FB. The output is set by the following formula :

$$V_{OUT} = 0.6 \times \left(1 + \frac{R2}{R3} \right)$$

Schematic, Bill of Materials & Board Layout

EVB Schematic Diagram

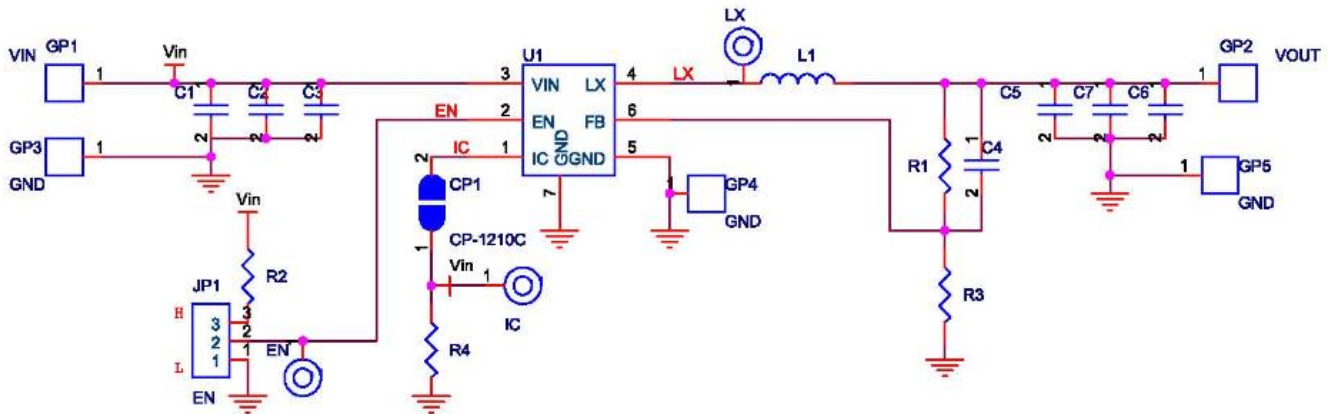

Bill of Materials

Reference	Qty	Part Number	Description	Package	Manufacture
U1	1	RT5710CHGQW	DC/DC Converter	WDFN-6L 2x2	RICHTEK
C1, C2	2	GRM31CR71E106KA12L	10 μ F/25V/X7R	C-1206	MURATA
C3, C5	2	C1608X7R1H104K080AA	0.1 μ F/ \pm 10%/50V/X7R	C-0603	MURATA
C4	1	0603N220J500	22pF/50V/NOP	C-0603	WALSIN
C6	1	GRM31CR71E106KA12L	10 μ F/25V/X7R	C-1206	MURATA
R1, R2, R3	3		100k Ω	R-0603	
R4	1		N/A		
L	1	SR04033R3MSB	3.3 μ H/2.15A	4.5 x 4 mm	ABC ELECTRONICS

PCB Layout

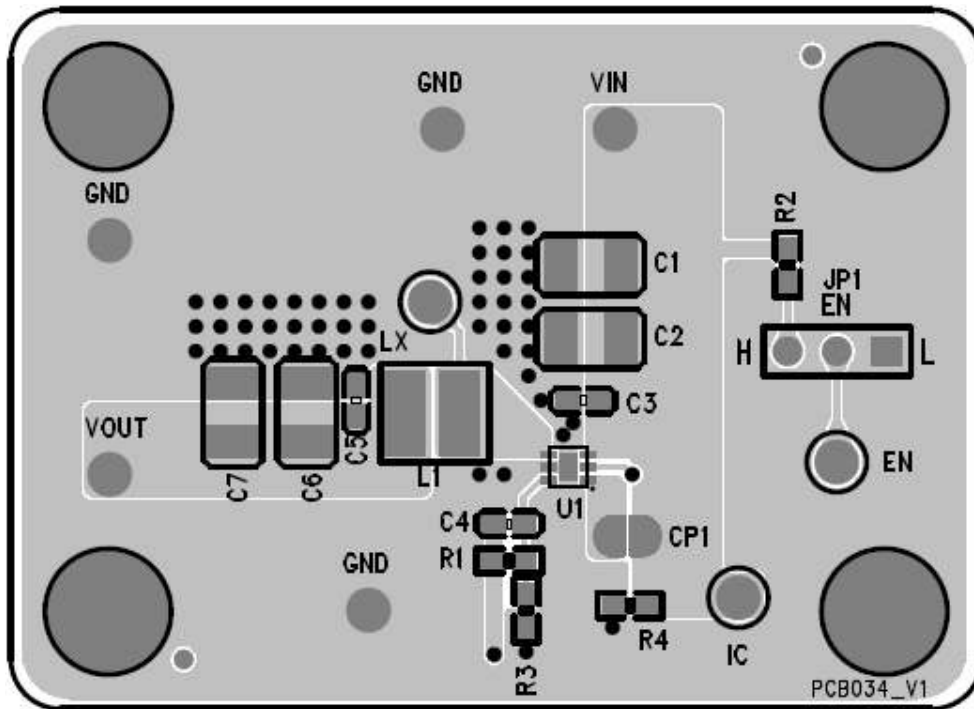

Top View (1st layer)

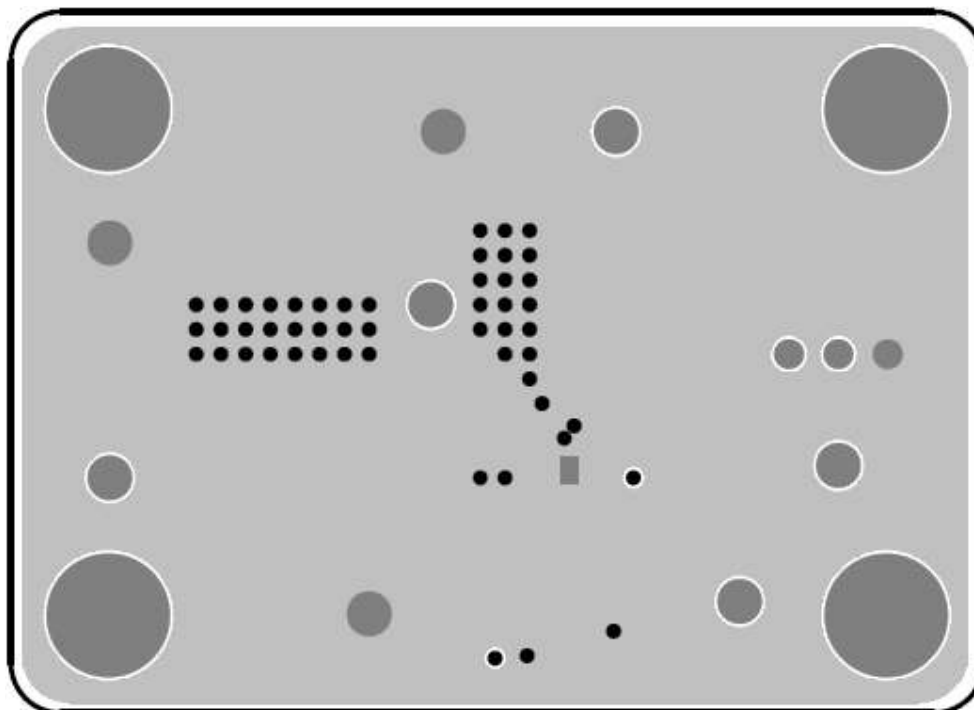

PCB Layout—Inner Side (2nd Layer)

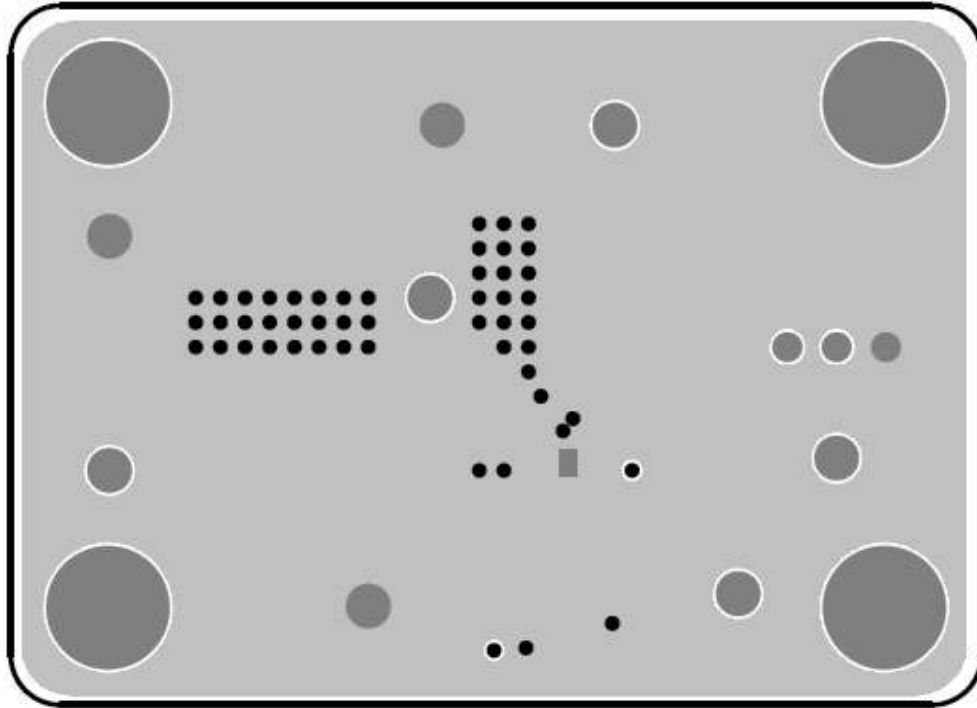

PCB Layout—Inner Side (3rd Layer)

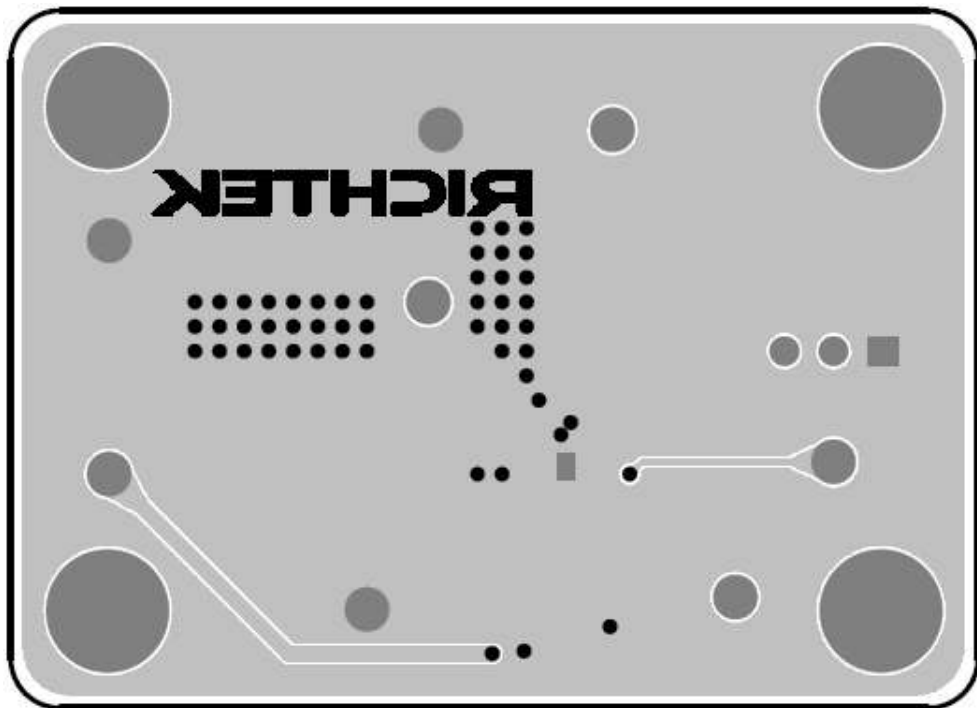

Bottom View (4th Layer)

More Information

For more information, please find the related datasheet or application notes from Richtek website <http://www.richtek.com>.

Important Notice for Richtek Evaluation Board

THIS DOCUMENT IS FOR REFERENCE ONLY, NOTHING CONTAINED IN THIS DOCUMENT SHALL BE CONSTRUED AS RICHTEK'S WARRANTY, EXPRESS OR IMPLIED, UNDER CONTRACT, TORT OR STATUTORY, WITH RESPECT TO THE PRESENTATION HEREIN. IN NO EVENT SHALL RICHTEK BE LIABLE TO BUYER OR USER FOR ANY AND ALL DAMAGES INCLUDING WITHOUT LIMITATION TO DIRECT, INDIRECT, SPECIAL, PUNITIVE OR CONSEQUENTIAL DAMAGES.