



# STEVAl-CCM003V1

## Graphic panel with ZigBee® features based on the STM32 and SPZBE260 module

Data brief

### Features

- Microsoft FAT16/FAT32 compatible library
- JPEG decoder algorithm
- S-Touch™-based touch keys for menu navigation
- MEMS-controlled image orientation based on frame alignment
- User programmable time interval for pictures
- ZigBee® module for user applications
- Date, time and temperature display
- USB mass-storage connectivity for picture transfer
- Rechargeable battery powered
- On-board JTAG connector for firmware upgrade
- RoHS compliant

### Description

The complete system is designed as two separate hardware units.

The STEVAL-CCM003V2 described in this document, also called “monitoring unit”, consists of a TFT and ZigBee® module interfaced with the STM32 for viewing / monitoring JPEG images.

The second unit, called the “camera unit” is the STEVAL-IFV001V1 and consists of a camera with a ZigBee® module interfaced with the STM32 microcontroller. The STM32 microcontroller in the camera unit captures JPEG images from the camera (using DMA) and transfers them to the ZigBee® network using the SPI-controlled SN260 module.

The images are transferred in JPEG format, which helps to reduce transfer time on the ZigBee® network. The camera unit can also record these images in the on-board memory (microSD card) using the FAT file system. The user can record these images at the click of a



button, or the system can be expanded to record the images when motion is detected by the camera (using the PIR sensor).

The monitoring unit scans for JPEG images on the ZigBee® network. Once the images are available on the network, it captures the images. These JPEG images are then converted into BMP format for display on the on-board TFT. Both units can be powered either from a battery or through USB. The system can be configured to enter standby mode as per the user configuration. This feature helps reduce system power consumption. These features render the system suitable for applications where certain areas require wireless monitoring, such as door phones or baby monitoring systems.

March 2010

Doc ID 17198 Rev 1

1/7

For further information contact your local STMicroelectronics sales office.

[www.st.com](http://www.st.com)

# 1 Schematic diagrams

Figure 1. Microcontroller circuit schematic

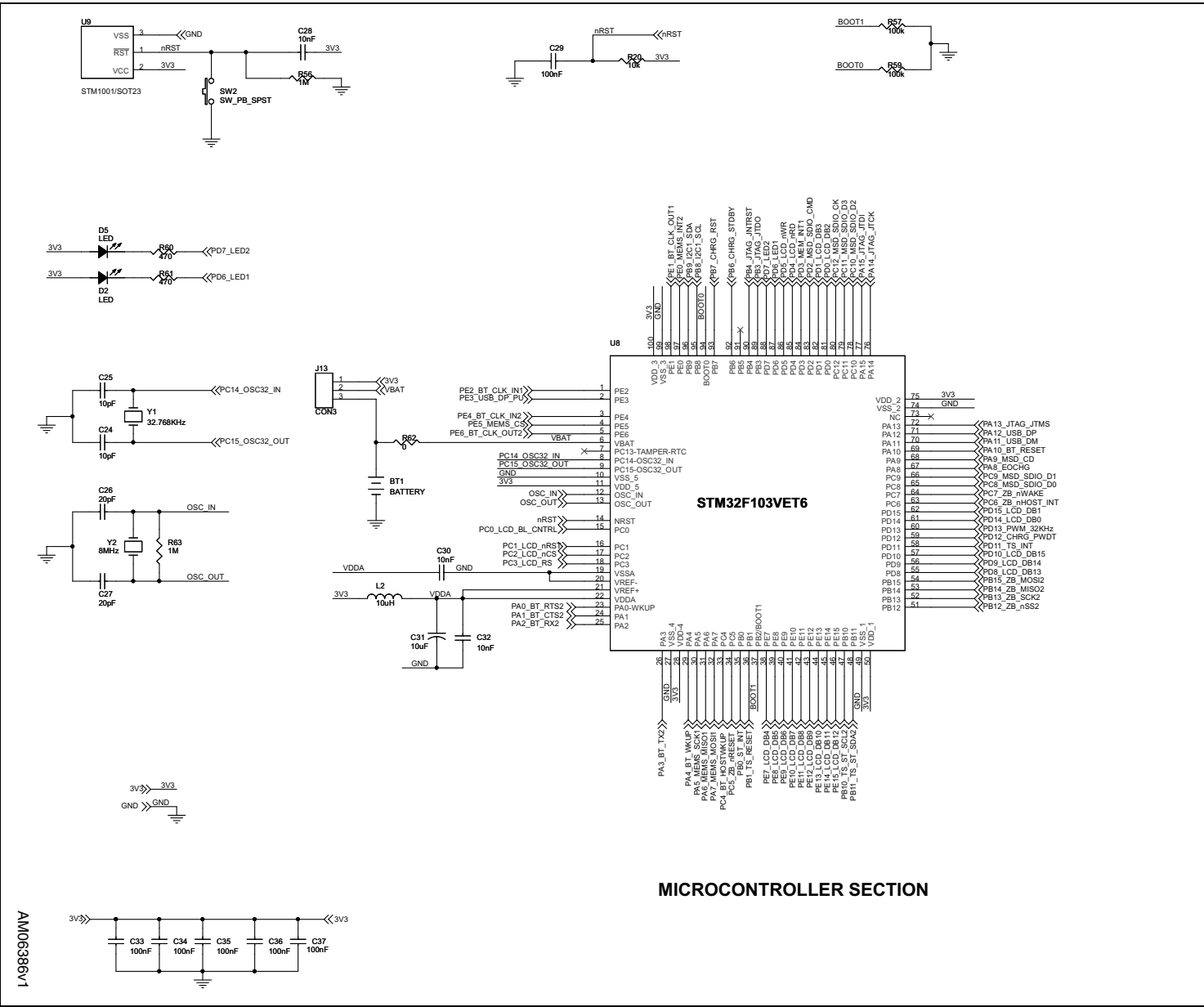

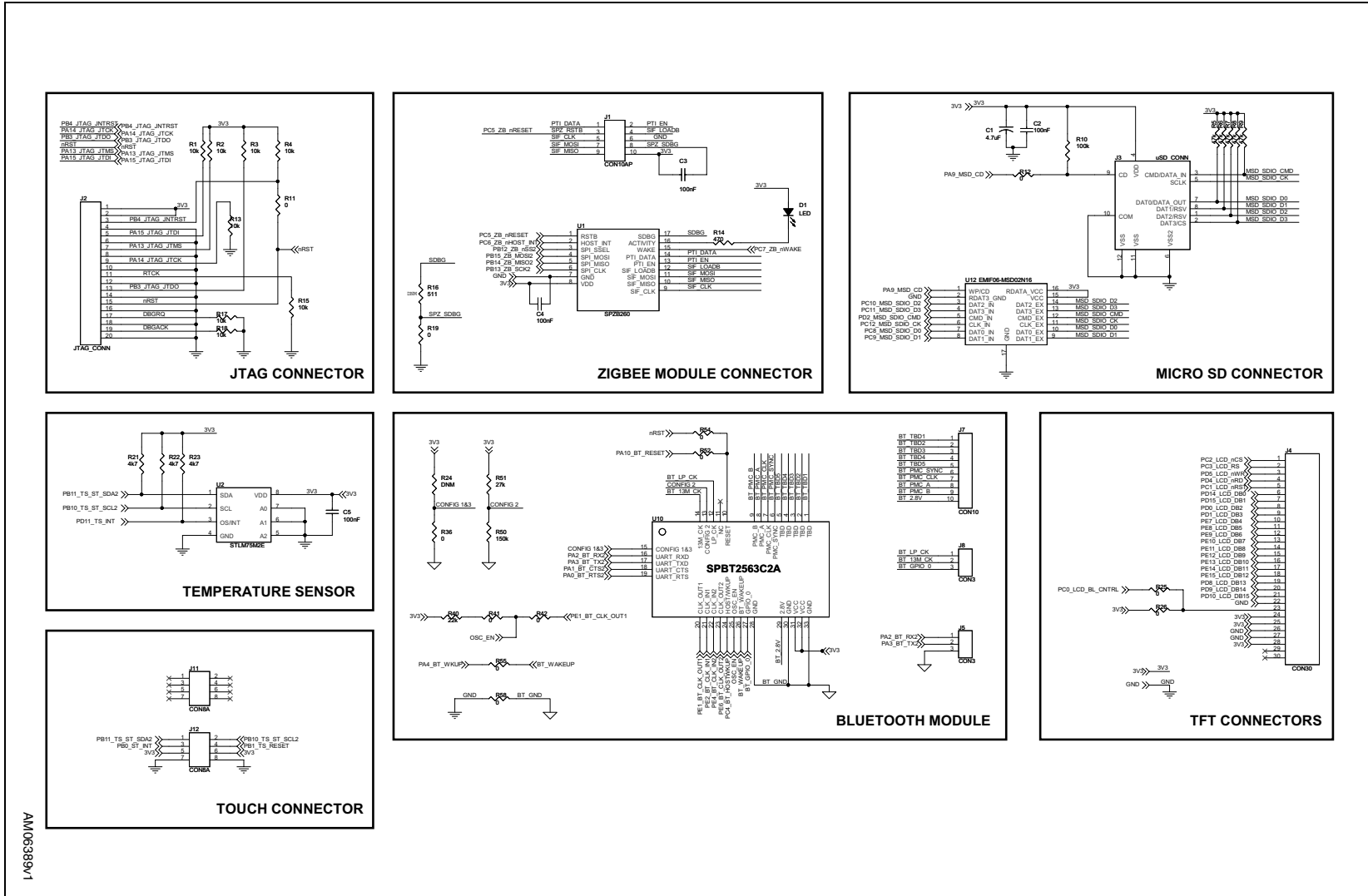

AM069389v1

Figure 2. Connector circuit schematics

Figure 3. Power, MEMS and USB section schematics

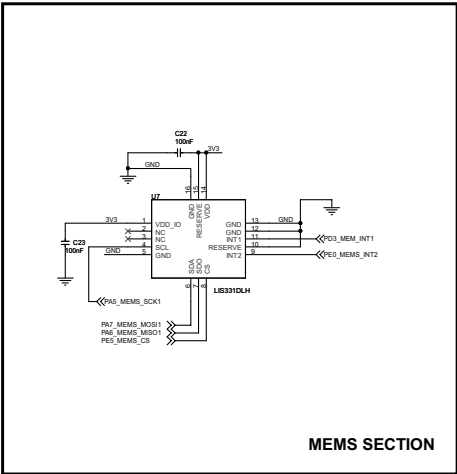
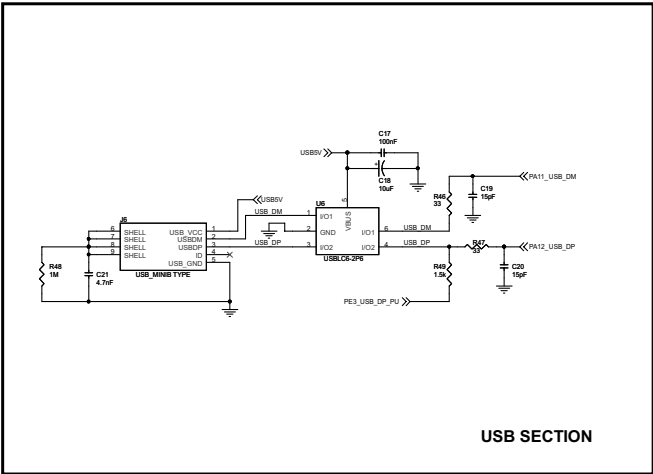
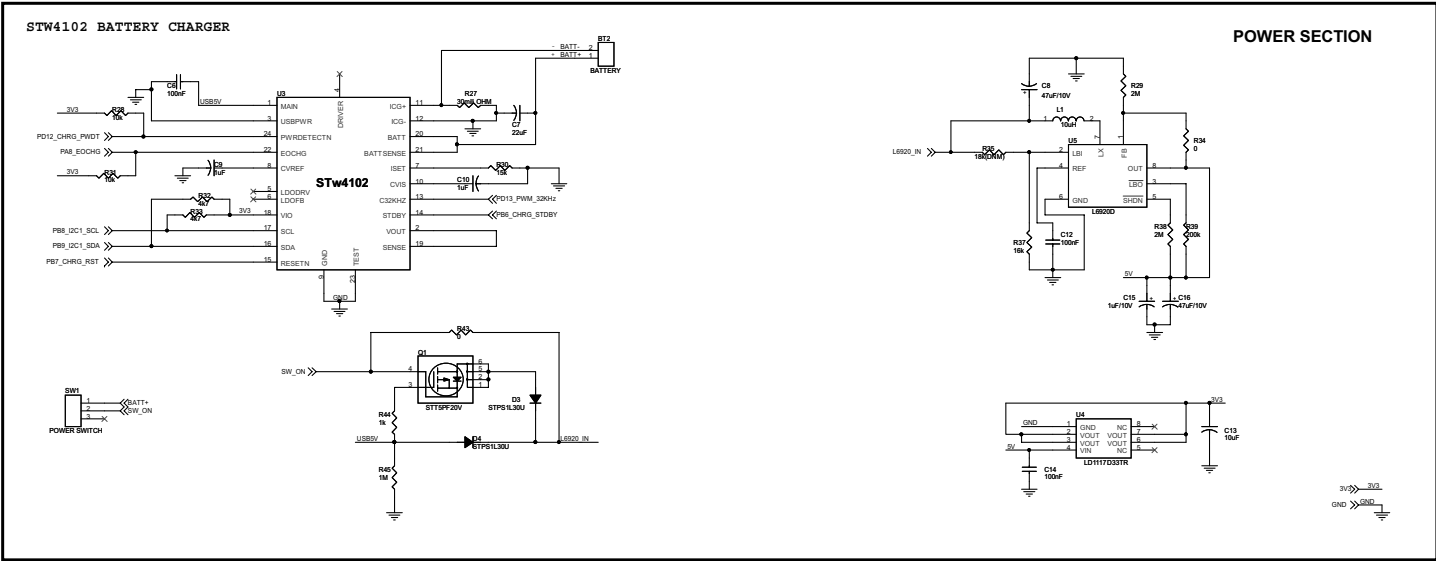
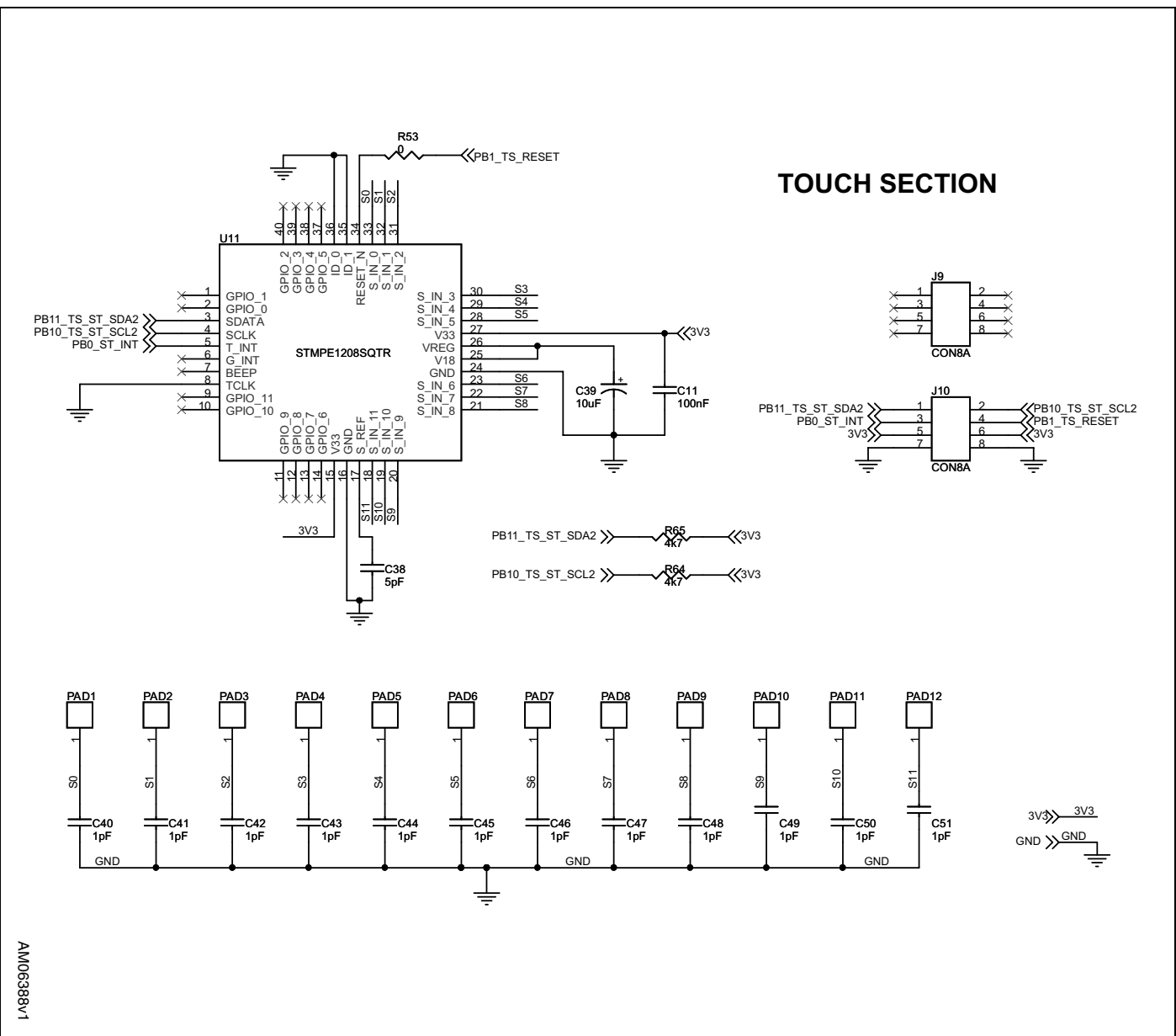

Figure 4. Touch section schematic



AM06388v1



## 2 Revision history

Table 1. Document revision history

Date	Revision	Changes
09-Mar-2010	1	Initial release.

**Please Read Carefully:**

Information in this document is provided solely in connection with ST products. STMicroelectronics NV and its subsidiaries ("ST") reserve the right to make changes, corrections, modifications or improvements, to this document, and the products and services described herein at any time, without notice.

All ST products are sold pursuant to ST's terms and conditions of sale.

Purchasers are solely responsible for the choice, selection and use of the ST products and services described herein, and ST assumes no liability whatsoever relating to the choice, selection or use of the ST products and services described herein.

No license, express or implied, by estoppel or otherwise, to any intellectual property rights is granted under this document. If any part of this document refers to any third party products or services it shall not be deemed a license grant by ST for the use of such third party products or services, or any intellectual property contained therein or considered as a warranty covering the use in any manner whatsoever of such third party products or services or any intellectual property contained therein.

**UNLESS OTHERWISE SET FORTH IN ST'S TERMS AND CONDITIONS OF SALE ST DISCLAIMS ANY EXPRESS OR IMPLIED WARRANTY WITH RESPECT TO THE USE AND/OR SALE OF ST PRODUCTS INCLUDING WITHOUT LIMITATION IMPLIED WARRANTIES OF MERCHANTABILITY, FITNESS FOR A PARTICULAR PURPOSE (AND THEIR EQUIVALENTS UNDER THE LAWS OF ANY JURISDICTION), OR INFRINGEMENT OF ANY PATENT, COPYRIGHT OR OTHER INTELLECTUAL PROPERTY RIGHT.**

**UNLESS EXPRESSLY APPROVED IN WRITING BY AN AUTHORIZED ST REPRESENTATIVE, ST PRODUCTS ARE NOT RECOMMENDED, AUTHORIZED OR WARRANTED FOR USE IN MILITARY, AIR CRAFT, SPACE, LIFE SAVING, OR LIFE SUSTAINING APPLICATIONS, NOR IN PRODUCTS OR SYSTEMS WHERE FAILURE OR MALFUNCTION MAY RESULT IN PERSONAL INJURY, DEATH, OR SEVERE PROPERTY OR ENVIRONMENTAL DAMAGE. ST PRODUCTS WHICH ARE NOT SPECIFIED AS "AUTOMOTIVE GRADE" MAY ONLY BE USED IN AUTOMOTIVE APPLICATIONS AT USER'S OWN RISK.**

Resale of ST products with provisions different from the statements and/or technical features set forth in this document shall immediately void any warranty granted by ST for the ST product or service described herein and shall not create or extend in any manner whatsoever, any liability of ST.

ST and the ST logo are trademarks or registered trademarks of ST in various countries.

Information in this document supersedes and replaces all information previously supplied.

The ST logo is a registered trademark of STMicroelectronics. All other names are the property of their respective owners.

© 2010 STMicroelectronics - All rights reserved

STMicroelectronics group of companies

Australia - Belgium - Brazil - Canada - China - Czech Republic - Finland - France - Germany - Hong Kong - India - Israel - Italy - Japan -  
Malaysia - Malta - Morocco - Philippines - Singapore - Spain - Sweden - Switzerland - United Kingdom - United States of America

[www.st.com](http://www.st.com)

