

KAPTON TAPE
SEE NOTE 6 AND 7

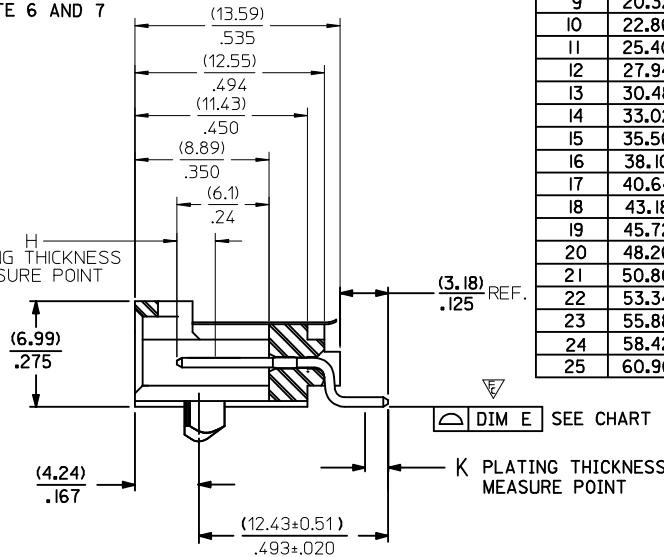
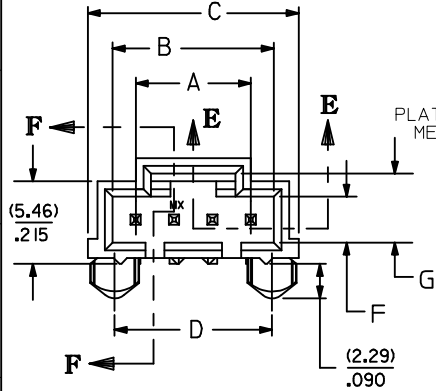

SECTION F-F

NOTES

- 1) HOUSING MATERIAL: HIGH TEMPERATURE GLASS FILLED POLYESTER, 94V-0, COLOR: BLACK.
PIN MATERIAL: PHOSPHOR BRONZE
- 2) HEADER MATES TO 70400-**** AND 70430-**** OPTION "G" SERIES CONNECTORS.
- 3) FOR PACKAGING OPTIONS REFER TO CHART ON SHEET 2.
- 4) SEE SHEET 2 FOR PIN PLATINGS.
- 5) REFER TO MOLEX PRODUCT SPECIFICATION PS-70541.
- 6) SEE CHART ON SHEET 2 TO DETERMINE PART NUMBERS WITH KAPTON TAPE.
- 7) KAPTON TAPE ADDED FOR PICK AND PLACE SYSTEMS. REMOVE KAPTON TAPE AFTER SOLDERING TO PREVENT INTERFERENCE WITH LATCH ON MATING PART.

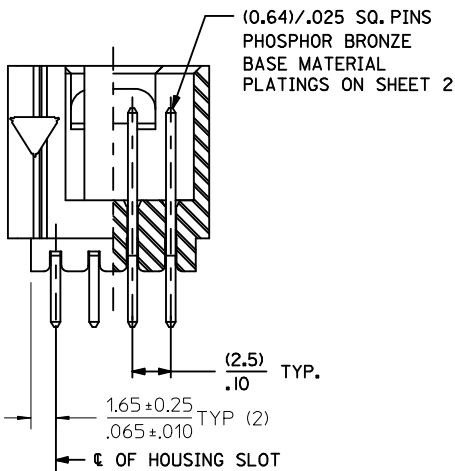

SECTION E-E

CKT. SIZE	"A"		"B"		"C"		"D"		"E"		"F"		"G"	
	MM	IN.	MM	IN.	MM	IN.	MM	IN.	MM	IN.	MM	IN.	MM	IN.
2	2.54	.100	5.33	.210	8.64	.340	5.33	.210	0.13	.005	2.79	.110	4.32	.170
3	5.08	.200	8.13	.320	11.43	.450	7.87	.310	0.13	.005	3.05	.120	4.57	.180
4	7.62	.300	10.67	.420	13.97	.550	10.41	.410	0.13	.005	3.05	.120	4.57	.180
5	10.16	.400	13.21	.520	16.51	.650	12.95	.510	0.13	.005	3.05	.120	4.57	.180
6	12.70	.500	15.75	.620	19.05	.750	15.49	.610	0.13	.005	3.05	.120	4.57	.180
7	15.24	.600	18.29	.720	21.59	.850	18.03	.710	0.13	.005	3.05	.120	4.57	.180
8	17.78	.700	20.83	.820	24.13	.950	20.57	.810	0.13	.005	3.05	.120	4.57	.180
9	20.32	.800	23.37	.920	26.67	1.050	23.11	.910	0.13	.005	3.05	.120	4.57	.180
10	22.86	.900	25.91	1.020	29.21	1.150	25.65	1.010	0.13	.005	3.05	.120	4.57	.180
11	25.40	1.000	28.45	1.120	31.75	1.250	28.19	1.110	0.13	.005	3.05	.120	4.57	.180
12	27.94	1.100	30.99	1.220	34.29	1.350	30.73	1.210	0.13	.005	3.05	.120	4.57	.180
13	30.48	1.200	33.53	1.320	36.83	1.450	33.27	1.310	0.13	.005	3.05	.120	4.57	.180
14	33.02	1.300	36.07	1.420	39.37	1.550	35.81	1.410	0.13	.005	3.05	.120	4.57	.180
15	35.56	1.400	38.61	1.520	41.91	1.650	38.35	1.510	0.13	.005	3.05	.120	4.57	.180
16	38.10	1.500	41.15	1.620	44.45	1.750	40.89	1.610	0.15	.006	3.05	.120	4.57	.180
17	40.64	1.600	43.69	1.720	46.99	1.850	43.43	1.710	0.15	.006	3.05	.120	4.57	.180
18	43.18	1.700	46.23	1.820	49.53	1.950	45.97	1.810	0.15	.006	3.05	.120	4.57	.180
19	45.72	1.800	48.77	1.920	52.07	2.050	48.51	1.910	0.15	.006	3.05	.120	4.57	.180
20	48.26	1.900	51.31	2.020	54.61	2.150	51.05	2.010	0.15	.006	3.05	.120	4.57	.180
21	50.80	2.000	53.85	2.120	57.15	2.250	53.59	2.110	0.18	.007	3.05	.120	4.57	.180
22	53.34	2.100	56.39	2.220	59.69	2.350	56.13	2.210	0.18	.007	3.05	.120	4.57	.180
23	55.88	2.200	58.93	2.320	62.23	2.450	58.67	2.310	0.18	.007	3.05	.120	4.57	.180
24	58.42	2.300	61.47	2.420	64.77	2.550	61.21	2.410	0.18	.007	3.05	.120	4.57	.180
25	60.96	2.400	64.01	2.520	67.31	2.650	63.75	2.510	0.18	.007	3.05	.120	4.57	.180

OPTION "E"

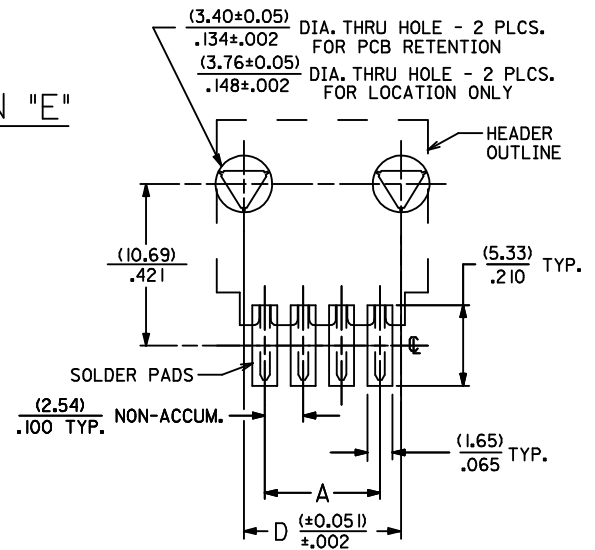

RECOMMENDED P.C. BOARD PAD LAYOUT

TABULATE DIM F & G EC NO: UCP2013-5147 DRWINDMORGAN 2013/05/28 CHKD:MPOFF 2013/05/28 APPR:SMILLER 2013/06/05	QUALITY SYMBOLS ∇=0 ∇=0 ∇=0	GENERAL TOLERANCES (UNLESS SPECIFIED) mm INCH 4 PLACES ± --- ± --- 3 PLACES ± --- ± .005 2 PLACES ± 0.13 ± .010 1 PLACE ± 0.25 ± --- 0 PLACE ± --- ± ---	DIMENSION STYLE MM/IN DRAWN BY DATE EIK 1993/06/02 CHECKED BY DATE EIK 1993/06/02 APPROVED BY DATE SMILLER 2010/02/08	SCALE 4:1	DESIGN UNITS INCH	THIRD ANGLE PROJECTION
		ANGULAR ±1/2° DRAFT WHERE APPLICABLE MUST REMAIN WITHIN DIMENSIONS	MATERIAL NO. SEE TABLE	DOCUMENT NO. SDA-70634-****	SHEET NO. 1 OF 3	

SALES ASSEMBLY
SMT HEADER - RIGHT ANGLE
.100 CENTERS W/PCB PEGS

THIS DRAWING CONTAINS INFORMATION THAT IS PROPRIETARY TO MOLEX INCORPORATED AND SHOULD NOT BE USED WITHOUT WRITTEN PERMISSION

13	12	11	10	9	8	7	6	5	4	3	2	1
J	ENGINEERING NUMBER A-70634-	MANUFACTURE RELEASE STATUS				PLATING TYPE SEE BELOW	CONNECTOR END PLATING TYPE	P.C. BOARD END PLATING H MEASURE POINT	K MEASURE POINT	KAPTON TAPE	OPTION	PACKAGE PER PK-70873
	-0001-0024	R.F.M.				TIN	TIN	(2.54) .100	(1.27) .050	NO	TUBE	-016
	-0036-0059	R.F.M.				15 GOLD	GOLD	(2.54) .100	(1.27) .050	NO	TUBE	-016
	-0071-0094	R.F.M.				30 GOLD	GOLD	(2.54) .100	(1.27) .050	NO	TUBE	-016
	-0106-0129	R.F.M.				TIN	TIN	(2.54) .100	(1.27) .050	YES	CARRIER TAPE	-001
	-0141-0164	R.F.M.				15 GOLD	GOLD	(2.54) .100	(1.27) .050	YES	CARRIER TAPE	-001
H	-0176-0199	R.F.M.				30 GOLD	GOLD	(2.54) .100	(1.27) .050	YES	CARRIER TAPE	-001

CKTS	EDP NUMBER	ENG NUMBER	EDP NUMBER	ENG NUMBER	EDP NUMBER	ENG NUMBER	EDP NUMBER	ENG NUMBER	EDP NUMBER	ENG NUMBER	EDP NUMBER	ENG NUMBER	EDP NUMBER	ENG NUMBER	CKTS
02	15-91-3024	A-70634-0001	15-91-2025	A-70634-0036	15-91-3023	A-70634-0071	15-91-6029	A-70634-0106	15-91-7020	A-70634-0141	15-91-7021	A-70634-0176			02
03	15-91-3034	A-70634-0002	15-91-2035	A-70634-0037	15-91-3033	A-70634-0072	15-91-6039	A-70634-0107	15-91-7030	A-70634-0142	15-91-7031	A-70634-0177			03
04	15-91-3044	A-70634-0003	15-91-2045	A-70634-0038	15-91-3043	A-70634-0073	15-91-6049	A-70634-0108	15-91-7040	A-70634-0143	15-91-7041	A-70634-0178			04
05	15-91-3054	A-70634-0004	15-91-2055	A-70634-0039	15-91-3053	A-70634-0074	15-91-6059	A-70634-0109	15-91-7050	A-70634-0144	15-91-7051	A-70634-0179			05
06	15-91-3064	A-70634-0005	15-91-2065	A-70634-0040	15-91-3063	A-70634-0075	15-91-6069	A-70634-0110	15-91-7060	A-70634-0145	15-91-7061	A-70634-0180			06
07	15-91-3074	A-70634-0006	15-91-2075	A-70634-0041	15-91-3073	A-70634-0076	15-91-6079	A-70634-0111	15-91-7070	A-70634-0146	15-91-7071	A-70634-0181			07
08	15-91-3084	A-70634-0007	15-91-2085	A-70634-0042	15-91-3083	A-70634-0077	15-91-6089	A-70634-0112	15-91-7080	A-70634-0147	15-91-7081	A-70634-0182			08
09	15-91-3094	A-70634-0008	15-91-2095	A-70634-0043	15-91-3093	A-70634-0078	15-91-6099	A-70634-0113	15-91-7090	A-70634-0148	15-91-7091	A-70634-0183			09
10	15-91-3104	A-70634-0009	15-91-2105	A-70634-0044	15-91-3103	A-70634-0079	15-91-6109	A-70634-0114	15-91-7100	A-70634-0149	15-91-7101	A-70634-0184			10
11	15-91-3114	A-70634-0010	15-91-2115	A-70634-0045	15-91-3113	A-70634-0080	15-91-6119	A-70634-0115	15-91-7110	A-70634-0150	15-91-7111	A-70634-0185			11
12	15-91-3124	A-70634-0011	15-91-2125	A-70634-0046	15-91-3123	A-70634-0081	15-91-6129	A-70634-0116	15-91-7120	A-70634-0151	15-91-7121	A-70634-0186			12
13	15-91-3134	A-70634-0012	15-91-2135	A-70634-0047	15-91-3133	A-70634-0082	15-91-6139	A-70634-0117	15-91-7130	A-70634-0152	15-91-7131	A-70634-0187			13
14	15-91-3144	A-70634-0013	15-91-2145	A-70634-0048	15-91-3143	A-70634-0083	15-91-6149	A-70634-0118	15-91-7140	A-70634-0153	15-91-7141	A-70634-0188			14
15	15-91-3154	A-70634-0014	15-91-2155	A-70634-0049	15-91-3153	A-70634-0084	15-91-6159	A-70634-0119	15-91-7150	A-70634-0154	15-91-7151	A-70634-0189			15
16	15-91-3164	A-70634-0015	15-91-2165	A-70634-0050	15-91-3163	A-70634-0085	15-91-6169	A-70634-0120	15-91-7160	A-70634-0155	15-91-7161	A-70634-0190			16
17	15-91-3174	A-70634-0016	15-91-2175	A-70634-0051	15-91-3173	A-70634-0086	15-91-6179	A-70634-0121	15-91-7170	A-70634-0156	15-91-7171	A-70634-0191			17
18	15-91-3184	A-70634-0017	15-91-2185	A-70634-0052	15-91-3183	A-70634-0087	15-91-6189	A-70634-0122	15-91-7180	A-70634-0157	15-91-7181	A-70634-0192			18
19	15-91-3194	A-70634-0018	15-91-2195	A-70634-0053	15-91-3193	A-70634-0088	15-91-6199	A-70634-0123	15-91-7190	A-70634-0158	15-91-7191	A-70634-0193			19
20	15-91-3204	A-70634-0019	15-91-2205	A-70634-0054	15-91-3203	A-70634-0089	15-91-6209	A-70634-0124	15-91-7200	A-70634-0159	15-91-7201	A-70634-0194			20
21	15-91-3214	A-70634-0020	15-91-2215	A-70634-0055	15-91-3213	A-70634-0090	15-91-6219	A-70634-0125	15-91-7210	A-70634-0160	15-91-7211	A-70634-0195			21
22	15-91-3224	A-70634-0021	15-91-2225	A-70634-0056	15-91-3223	A-70634-0091	15-91-6229	A-70634-0126	15-91-7220	A-70634-0161	15-91-7221	A-70634-0196			22
23	15-91-3234	A-70634-0022	15-91-2235	A-70634-0057	15-91-3233	A-70634-0092	15-91-6239	A-70634-0127	15-91-7230	A-70634-0162	15-91-7231	A-70634-0197			23
24	15-91-3244	A-70634-0023	15-91-2245	A-70634-0058	15-91-3243	A-70634-0093	15-91-6249	A-70634-0128	15-91-7240	A-70634-0163	15-91-7241	A-70634-0198			24
25	15-91-3254	A-70634-0024	15-91-2255	A-70634-0059	15-91-3253	A-70634-0094	15-91-6259	A-70634-0129	15-91-7250	A-70634-0164	15-91-7251	A-70634-0199			25

PLATING TYPE

TIN TIN (Sn) OVER ENTIRE PIN; THICKNESS=(3.75 MICROMETER)/75 MICROINCH MINIMUM; NICKEL (Ni) UNDERPLATE OVER ENTIRE PIN.

15 GOLD SELECTIVE GOLD (Au) IN THE CONTACT AREA; THICKNESS=(0.37 MICROMETER)/15 MICROINCH MINIMUM; SELECTIVE TIN (Sn) IN THE PC TAIL AREA; THICKNESS=(1.88 MICROMETER)/75 MICROINCH MINIMUM; NICKEL (Ni) UNDERPLATE OVER ENTIRE PIN.

30 GOLD SELECTIVE GOLD (Au) IN THE CONTACT AREA; THICKNESS=(0.75 MICROMETER)/30 MICROINCH MINIMUM; SELECTIVE TIN (Sn) IN THE PC TAIL AREA; THICKNESS=(1.88 MICROMETER)/75 MICROINCH MINIMUM; NICKEL (Ni) UNDERPLATE OVER ENTIRE PIN.

B	SEE SHEET 1 EC NO: UCP2013-5147 DRWING:MORGAN 2013/05/28 CHKD:MPOFF 2013/05/28 APPR:SMILLER 2013/06/05	QUALITY SYMBOLS 	GENERAL TOLERANCES (UNLESS SPECIFIED)		DIMENSION STYLE MM/IN		SCALE	DESIGN UNITS INCH	THIRD ANGLE PROJECTION
					DRAWN BY EIK	DATE 1993/06/02	TITLE SALES ASSEMBLY SMT HEADER - RIGHT ANGLE .100 CENTERS W/PCB PEGS		
					CHECKED BY EIK	DATE 1993/06/02			
					APPROVED BY SMILLER	DATE 2010/02/08			
A			ANGULAR ±1/2°		MATERIAL NO.		DOCUMENT NO.	SHEET NO.	
			DRAFT WHERE APPLICABLE MUST REMAIN WITHIN DIMENSIONS		SEE TABLE		SDA-70634-****	2 OF 3	
			THIS DRAWING CONTAINS INFORMATION THAT IS PROPRIETARY TO MOLEX INCORPORATED AND SHOULD NOT BE USED WITHOUT WRITTEN PERMISSION						

ITEM NUMBER 70634-	PLATING TYPE SEE BELOW	CONNECTOR END PLATING		P.C. BOARD END PLATING		PACKAGING		
		TYPE	H MEASURE POINT	TYPE	K MEASURE POINT	KAPTON TAPE	OPTION	PACKAGE PER PK-70873
-0202-0225	50 GOLD	GOLD	(2.54) .100	TIN	(1.27) .050	NO	TUBE	-016

CKTS	ITEM NUMBER	ITEM NUMBER	ITEM NUMBER	ITEM NUMBER	ITEM NUMBER	ITEM NUMBER	CKTS
02	70634-0202						02
03	70634-0203						03
04	70634-0204						04
05	70634-0205						05
06	70634-0206						06
07	70634-0207						07
08	70634-0208						08
09	70634-0209						09
10	70634-0210						10
11	70634-0211						11
12	70634-0212						12
13	70634-0213						13
14	70634-0214						14
15	70634-0215						15
16	70634-0216						16
17	70634-0217						17
18	70634-0218						18
19	70634-0219						19
20	70634-0220						20
21	70634-0221						21
22	70634-0222						22
23	70634-0223						23
24	70634-0224						24
25	70634-0225						25

PLATING TYPE

50 GOLD SELECTIVE GOLD (Au) IN THE CONTACT AREA: THICKNESS=(1.27 MICROMETER)/50 MICROINCH MINIMUM;
 SELECTIVE TIN (Sn) IN THE PC TAIL AREA: THICKNESS=(1.88 MICROMETER)/75 MICROINCH MINIMUM;
 NICKEL (Ni) UNDERPLATE OVER ENTIRE PIN.

SEE SHEET 1 EC NO: UCP2013-5147 DRWN:MORGAN 2013/05/28 CHKD:MPOFF 2013/05/28 APPR:SMILLER 2013/06/05	QUALITY SYMBOLS	GENERAL TOLERANCES (UNLESS SPECIFIED)	DIMENSION STYLE	SCALE	DESIGN UNITS	THIRD ANGLE PROJECTION
	▽=0	mm INCH	MM/IN	1:1	INCH	
	▽=0	4 PLACES ± --- ± ---	DRAWN BY DATE	TITLE		
	▽=0	3 PLACES ± --- ±.005	EIK 1993/06/02	SALES ASSEMBLY		
		2 PLACES ± 0.13 ±.010	CHECKED BY DATE	SMT HEADER - RIGHT ANGLE		
	1 PLACE ± 0.25 ± ---	EIK 1993/06/02	.100 CENTERS W/PCB PEGS			
	0 PLACE ± --- ± ---	APPROVED BY DATE	molex			
		SMILLER 2010/02/08	MATERIAL NO.	DOCUMENT NO.	SHEET NO.	
			SEE TABLE	SDA-70634-****	3 OF 3	
			THIS DRAWING CONTAINS INFORMATION THAT IS PROPRIETARY TO MOLEX INCORPORATED AND SHOULD NOT BE USED WITHOUT WRITTEN PERMISSION			