

8 7 6 5 4 3 2 1

REVISIONS				
ZONE	REV.	DESCRIPTION	DATE	APPROVED
ALL		ENGINEERING RELEASE		

ITEM NO	PART NO	DESCRIPTION	DETAIL DWG REF.	QTY.
1	SEE TABLE FOR PART NO	FRAME ALUM.	M 3926-D5.2	1
2		BASE ALUM.	M 4906-D5.11	1
3		SIDECOVER ALUM.	M 4906-D5.5	2
4	HD51	HARDWARE KIT		1

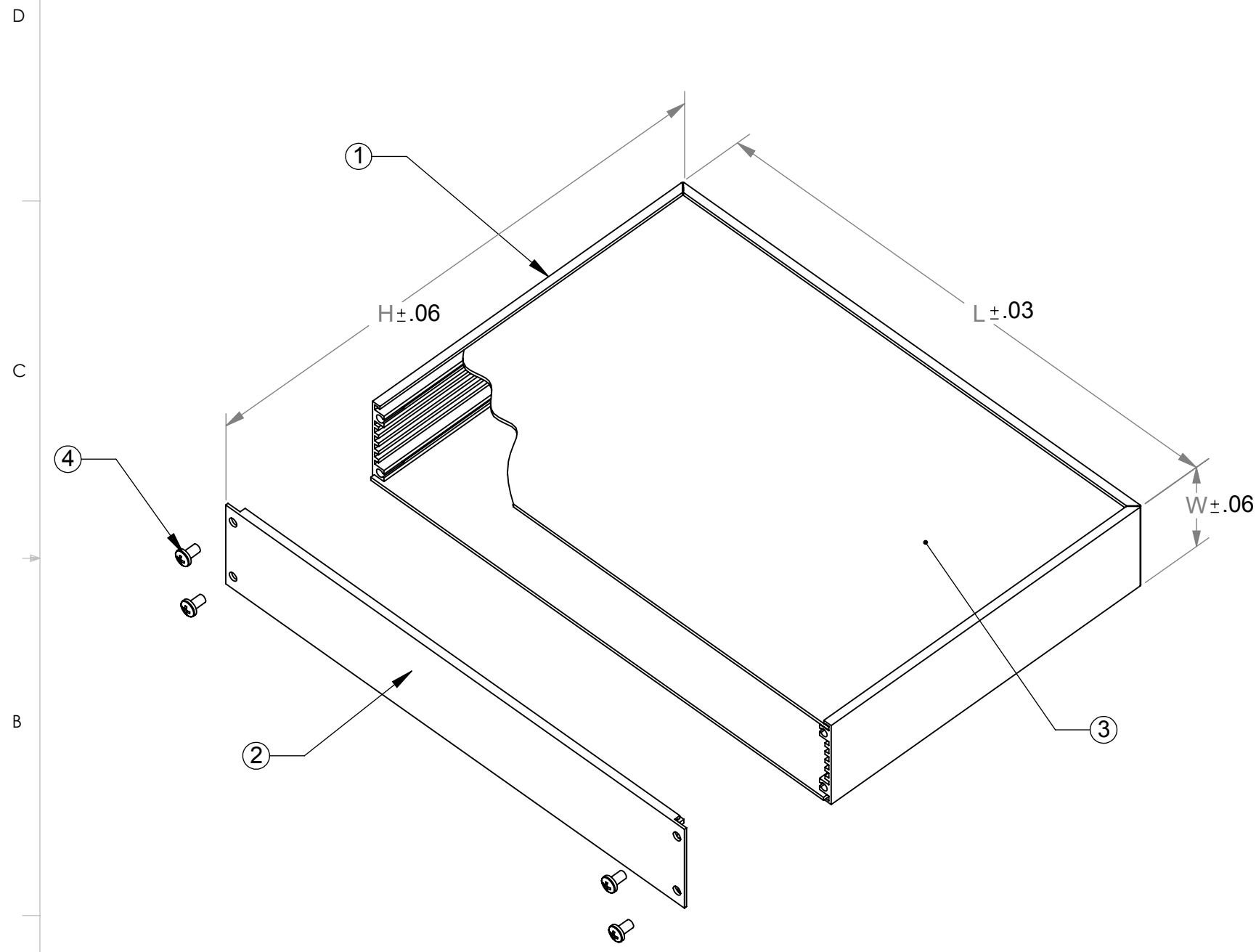

CAT. NO. FINISH:CLEA R ANODIZED	W (WIDTH)	L (LENGTH)	H (HEIGHT)	FRAME P/N ITEM 1	BASE P/N ITEM 2	SIDE COVER P/N ITEM 3	CARD SIZE REF.
W10-23-38B	1.000	2.310	3.810	M3926-2-21	SR1-23-3B	PL 2338	2.20 x 3.70
W16-12-12B	1.600	1.210	1.210	M3926-2-13	SR16-12-3B	PL 1212	1.10 x 1.10
W16-28-46B		2.850	4.610	M3926-2-15	SR16-28-3B	PL 2846	2.73 x 4.50
W16-31-21B		3.100	2.110	M3926-2-17	SR16-31-3B	PL 2131	2.98 x 2.00
W16-31-31B		3.100	3.100	M3926-2-19	SR16-31-3B	PL 3131	2.98 x 2.98
W16-46-31B	2.000	4.610	3.100	M3926-2-67	SR16-46-3B	PL 3045	4.50 x 2.98
W20-15-15B		1.510	1.510	M3926-2-23	SR2-15-3B	PL 1515	1.40 x 1.40
W20-28-15B		2.850	1.510	M3926-2-25	SR2-28-3B	PL 1528	2.73 x 1.40
W20-28-46B		2.850	4.610	M3926-2-27	SR2-28-3B	PL 2846	2.73 x 4.50
W20-31-31B		3.100	3.100	M3926-2-29	SR2-31-3B	PL 3131	2.98 x 2.98
W20-31-42B		3.100	4.171	M3926-2-1	SR2-31-3B	PL 3142	2.98 x 4.06
W20-46-31B		4.610	3.100	M3926-2-31	SR2-46-3B	PL 3045	4.50 x 2.98
W20-46-46B		4.610	4.620	M3926-2-33	SR2-46-3B	PL 4646	4.50 x 4.50
W20-46-62B		4.610	6.171	M3926-2-3	SR2-46-3B	PL 4662	4.50 x 6.06
W20-46-66B		4.610	6.610	M3926-2-35	SR2-46-3B	PL 4565	4.50 x 6.50
W20-61-36B		6.110	3.610	M3926-2-37	SR2-61-3B	PL 3661	6.00 x 3.50
W20-66-46B		6.610	4.610	M3926-2-39	SR2-66-3B	PL 4565	6.50 x 4.50
W30-46-46B	3.000	4.610	4.620	M3926-2-41	SR3-46-3B	PL 4646	4.50 x 4.50
W30-66-46B		6.610	4.610	M3926-2-43	SR3-66-3B	PL 4565	6.50 x 4.50
W30-86-45B		8.610	4.610	M3926-2-45	SR3-86-3B	PL 8646	8.50 x 4.50
W30-10-46B		10.000	4.610	M3926-2-47	SR3-10-3B	PL 10046	9.88 x 4.50
W30-10-66B	4.500	10.000	6.610	M3926-2-49	SR3-10-3B	PL 10066	9.88 x 6.50
W30-10-90B		10.000	8.000	M3926-2-63	SR3-10-3B	PL 10080	
W45-28-31B		2.850	2.110	M3926-2-51	SR45-28-3B	PL 2128	2.73 x 2.00
W45-46-21B		4.610	2.110	M3926-2-53	SR45-46-3B	PL 2146	4.40 x 2.00
W45-66-46B	10.000	6.610	4.610	M3926-2-55	SR45-66-3B	PL 4565	6.50 x 4.50
W45-86-46B		8.610	4.610	M3926-2-57	SR45-86-3B	PL 8646	8.50 x 4.50
W45-10-46B		10.000	4.610	M3926-2-59	SR45-10-3B	PL 10046	9.88 x 4.50
W45-10-66B		10.000	6.644	M3926-2-61	SR45-10-3B	PL 10066	9.88 x 6.50
53-0065	2.000	4.610	5.910	53-0065-02	53-0065-03	53-0065-01	
	1.600	9.307	6.346	M3926-2-20	SR16-93-3B		6U X 160mm

5. FOR OTHER THAN CLEAR ANOD. FINISH ADD COLOR CODE & FINISH LETTER TO CATALOG NO. AS REQ'D FOR S.E.S. 21
 4. FOR DUAL-TONED MULTI-MODS WITH BEZEL SEE DWG. M4906-D3.21 FOR SPEC. NOS. SEE DWG. MC4906-D3.10
 3. FOR SLIDING DOORS (SIDE COVERS) SEE DWG. M4906-D4.17
 2. CENTER TILT-UP BASE ON EXTR. BASE WITHIN .060 T.I.R.(DETAIL DWG. M4906-D5.22)
 1. FOUR BUMPFEET TO BE SUPPLIED WITH EACH UNIT AS SHOWN
- NOTES : UNLESS OTHERWISE SPECIFIED

PROPRIETARY AND CONFIDENTIAL
 THE INFORMATION CONTAINED IN THIS DRAWING IS THE SOLE PROPERTY OF VECTOR ELECTRONICS & TECH., INC. ANY REPRODUCTION IN PART OR AS A WHOLE WITHOUT THE WRITTEN PERMISSION OF VECTOR ELECTRONICS & TECH., INC. IS PROHIBITED.

UNLESS OTHERWISE SPECIFIED:

DIMENSIONS ARE IN INCHES
 TOLERANCES:
 FRACTIONAL ±
 ANGULAR: ±.5°
 TWO PLACE DECIMAL ±.03
 THREE PLACE DECIMAL ±.010
 INTERPRET GEOMETRIC TOLERANCING PER:

MATERIAL
 FINISH
 DO NOT SCALE DRAWING

NAME: TRUSHAR
 DATE: 11/04/08

DRAWN
 CHECKED
 ENG APPR.
 MFG APPR.
 Q.A.

THIRD ANGLE PROJECTION

VECTOR 11115 VANOWEN ST., NORTH HOLLYWOOD, CA 91605

MULTI-MOD CASE ASSEMBLY
VECTOR STANDARD(W-B SERIES)

SIZE DWG. NO. **B M4906 D3.9** REV

SCALE: 1:4 WEIGHT: SHEET 1 OF 3

8 7 6 5 4 3 2 1

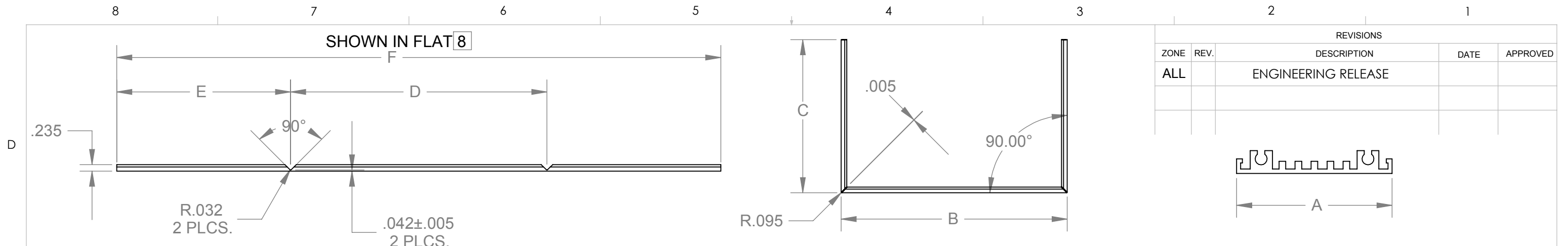

REVISIONS				
ZONE	REV.	DESCRIPTION	DATE	APPROVED
ALL		ENGINEERING RELEASE		

PART NO 8	MATERIAL	FINISH	A	B	C	D	E	F
M3926-2-1	SR2-062-0	4	2.000	3.100	4.125	3.025	4.087	11.199
M3926-2-2	SR2-062-0	4	2.000	3.100	8.600	3.025	8.562	20.149
M3926-2-3	SR2-062-0	4	2.000	4.610	6.125	4.535	6.087	16.709
M3926-2-4	SR2-062-0	4	2.000	4.610	8.600	4.535	8.562	21.659
M3926-2-5	SR16-062-0	4	1.600	3.100	4.125	3.025	4.087	11.199
M3926-2-6	SR16-062-0	4	1.600	4.610	6.125	4.535	6.087	16.709
M3926-2-7	SR2-062-0	N/A	2.000	3.100	4.125	3.025	4.087	11.199
M3926-2-8	SR2-062-0	N/A	2.000	3.100	8.600	3.025	8.562	20.149
M3926-2-9	SR2-062-0	N/A	2.000	4.610	6.125	4.535	6.087	16.709
M3926-2-10	SR2-062-0	N/A	2.000	4.610	8.600	4.535	8.562	21.659
M3926-2-11	SR16-062-0	N/A	1.600	3.100	4.125	3.025	4.087	11.199
M3926-2-12	SR16-062-0	N/A	1.600	4.610	6.125	4.535	6.087	16.709
M3926-2-13	SR16-062-0	4	1.600	1.210	1.164	1.135	1.126	3.387
M3926-2-14	SR16-062-0	N/A	1.600	1.210	1.164	1.135	1.126	3.387
M3926-2-15	SR16-062-0	4	1.600	2.850	4.564	2.775	4.526	11.827
M3926-2-16	SR16-062-0	N/A	1.600	2.850	4.564	2.775	4.526	11.827
M3926-2-17	SR16-062-0	4	1.600	3.100	2.064	3.025	2.026	7.077
M3926-2-18	SR16-062-0	N/A	1.600	3.100	2.064	3.025	2.026	7.077
M3926-2-19	SR16-062-0	4	1.600	3.100	3.054	3.025	3.016	9.057
M3926-2-20	SR16-062-0	N/A	1.600	3.100	3.054	3.025	3.016	9.057
M3926-2-21	SR1-062-0	4	1.000	2.310	3.764	2.235	3.726	9.687
M3926-2-22	SR1-062-0	N/A	1.000	2.310	3.764	2.235	3.726	9.687
M3926-2-23	SR2-062-0	4	2.000	1.510	1.464	1.435	1.426	4.287
M3926-2-24	SR2-062-0	N/A	2.000	1.510	1.464	1.435	1.426	4.287
M3926-2-25	SR2-062-0	4	2.000	2.850	1.464	2.775	1.426	5.627
M3926-2-26	SR2-062-0	N/A	2.000	2.850	1.464	2.775	1.426	5.627
M3926-2-27	SR2-062-0	4	2.000	2.850	4.564	2.775	4.526	11.827
M3926-2-28	SR2-062-0	N/A	2.000	2.850	4.564	2.775	4.526	11.827
M3926-2-29	SR2-062-0	4	2.000	3.100	3.054	3.025	3.016	9.057
M3926-2-30	SR2-062-0	N/A	2.000	3.100	3.054	3.025	3.016	9.057
M3926-2-31	SR2-062-0	4	2.000	4.610	3.054	4.535	3.016	10.567
M3926-2-32	SR2-062-0	N/A	2.000	4.610	3.054	4.535	3.016	10.567
M3926-2-33	SR2-062-0	4	2.000	4.610	4.574	4.535	4.536	13.607
M3926-2-34	SR2-062-0	N/A	2.000	4.610	4.574	4.535	4.536	13.607

PART NO 8	MATERIAL	FINISH	A	B	C	D	E	F
M3926-2-35	SR2-062-0	4	2.000	4.610	6.564	4.535	6.526	17.587
M3926-2-36	SR2-062-0	N/A	2.000	4.610	6.564	4.535	6.526	17.587
M3926-2-37	SR2-062-0	4	2.000	6.110	3.564	6.035	3.526	13.087
M3926-2-38	SR2-062-0	N/A	2.000	6.110	3.564	6.035	3.526	13.087
M3926-2-39	SR2-062-0	4	2.000	6.610	4.564	6.535	4.526	15.587
M3926-2-40	SR2-062-0	N/A	2.000	6.610	4.564	6.535	4.526	15.587
M3926-2-41	SR3-062-0	4	3.000	4.610	4.574	4.535	4.536	13.607
M3926-2-42	SR3-062-0	N/A	3.000	4.610	4.574	4.535	4.536	13.607
M3926-2-43	SR3-062-0	4	3.000	6.610	4.564	6.535	4.526	15.587
M3926-2-44	SR3-062-0	N/A	3.000	6.610	4.564	6.535	4.526	15.587
M3926-2-45	SR3-062-0	4	3.000	8.610	4.564	8.535	4.526	17.587
M3926-2-46	SR3-062-0	N/A	3.000	8.610	4.564	8.535	4.526	17.587
M3926-2-47	SR3-062-0	4	3.000	10.000	4.564	9.925	4.526	18.977
M3926-2-48	SR3-062-0	N/A	3.000	10.000	4.564	9.925	4.526	18.977
M3926-2-49	SR3-062-0	4	3.000	10.000	6.564	9.925	6.526	22.977
M3926-2-50	SR3-062-0	N/A	3.000	10.000	6.564	9.925	6.526	22.977
M3926-2-51	SR45-062-0	4	4.500	2.850	2.064	2.775	2.026	6.827
M3926-2-52	SR45-062-0	N/A	4.500	2.850	2.064	2.775	2.026	6.827
M3926-2-53	SR45-062-0	4	4.500	4.610	2.064	4.535	2.026	8.587
M3926-2-54	SR45-062-0	N/A	4.500	4.610	2.064	4.535	2.026	8.587
M3926-2-55	SR45-062-0	4	4.500	6.610	4.564	6.535	4.526	15.587
M3926-2-56	SR45-062-0	N/A	4.500	6.610	4.564	6.535	4.526	15.587
M3926-2-57	SR45-062-0	4	4.500	8.610	4.564	8.535	4.526	17.587
M3926-2-58	SR45-062-0	N/A	4.500	8.610	4.564	8.535	4.526	17.587
M3926-2-59	SR45-062-0	4	4.500	10.000	4.564	9.925	4.526	18.977
M3926-2-60	SR45-062-0	N/A	4.500	10.000	4.564	9.925	4.526	18.977
M3926-2-61	SR45-062-0	4	4.500	10.000	6.564	9.925	6.526	22.977
M3926-2-62	SR45-062-0	N/A	4.500	10.000	6.564	9.925	6.526	22.977
M3926-2-63	SR3-062-0	4	3.000	10.000	7.954	9.925	7.916	25.757
M3926-2-64	SR3-062-0	N/A	3.000	10.000	7.954	9.925	7.916	25.757
M3926-2-65	SR2-062-0	4	2.000	2.850	4.574	2.775	4.536	11.847
M3926-2-66	SR2-062-0	N/A	2.000	2.850	4.574	2.775	4.536	11.847
M3926-2-67	SR16-062-0	4	1.600	4.610	3.050	4.535	3.012	10.559
M3926-2-68	SR1-062-0	4	1.000	8.214	9.194	8.139	9.156	26.451

5. REF. INFORMATION

DIM. A = STD. MATL. WIDTH
 B = CASE LENGTH
 C = CASE HEIGHT - .046
 (CASE HEIGHT OF STYLE "B")
 D = B - .075
 E = C - .038
 F = 2E + D

8. PART NO. SHOWN ARE FOR "IN THE FLAT" CONDITION
 7. FLATNESS : .015"/FOOT IN LENGTH ; .004"/INCH IN WIDTH ; TWIST 1°/FOOT
 6. CUT ENDS TO BE SQUARE WITHIN .0025/INCH IN WIDTH
 4. FINISH : ANOD., CLEAR, TYPE II, CLASS 1, IAW MIL-A-8625
 3. DEGREASE
 2. REMOVE ALL BURS & SHARP EDGES
 1. MAT'L : AL. EXTRUSION, P/N# : SEE TABLE
- NOTES : UNLESS OTHERWISE SPECIFIED

PROPRIETARY AND CONFIDENTIAL
 THE INFORMATION CONTAINED IN THIS DRAWING IS THE SOLE PROPERTY OF VECTOR ELECTRONICS & TECH., INC. ANY REPRODUCTION IN PART OR AS A WHOLE WITHOUT THE WRITTEN PERMISSION OF VECTOR ELECTRONICS & TECH., INC. IS PROHIBITED.

DIMENSIONS ARE IN INCHES
 TOLERANCES:
 FRACTIONAL ±
 ANGULAR: ±.5°
 TWO PLACE DECIMAL ±.03
 THREE PLACE DECIMAL ±.010
 INTERPRET GEOMETRIC TOLERANCING PER:
 MATERIAL **1**
 FINISH **4**
 DO NOT SCALE DRAWING

	NAME	DATE
DRAWN	TRUSHAR	07/22/08
CHECKED		
ENG APPR.		
MFG APPR.		
Q.A.		

VECTOR 11115 VANOWEN ST., NORTH HOLLYWOOD, CA 91605
 ELECTRONICS & TECHNOLOGY, INC

FRAME, EXTRUDED VECTORPAK & MULTI-MOD CASES

SIZE DWG. NO. **B M3926D5.2** REV **D**

SCALE: 1:4 WEIGHT: SHEET 2 OF 3

REVISIONS				
ZONE	REV.	DESCRIPTION	DATE	APPROVED
ALL		ENGINEERING RELEASE		

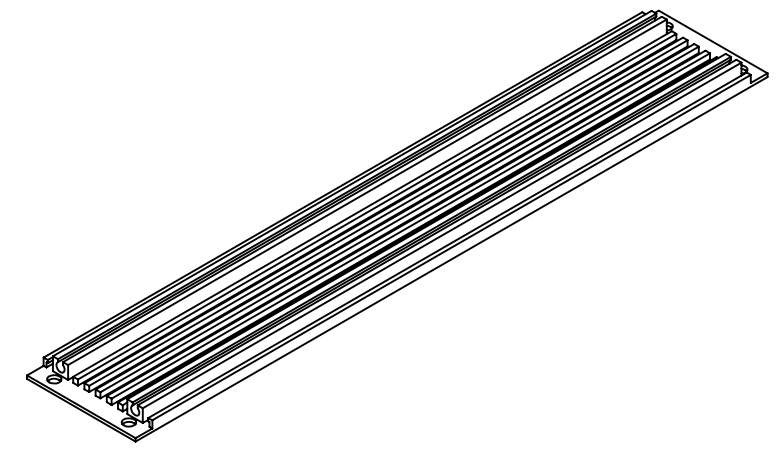
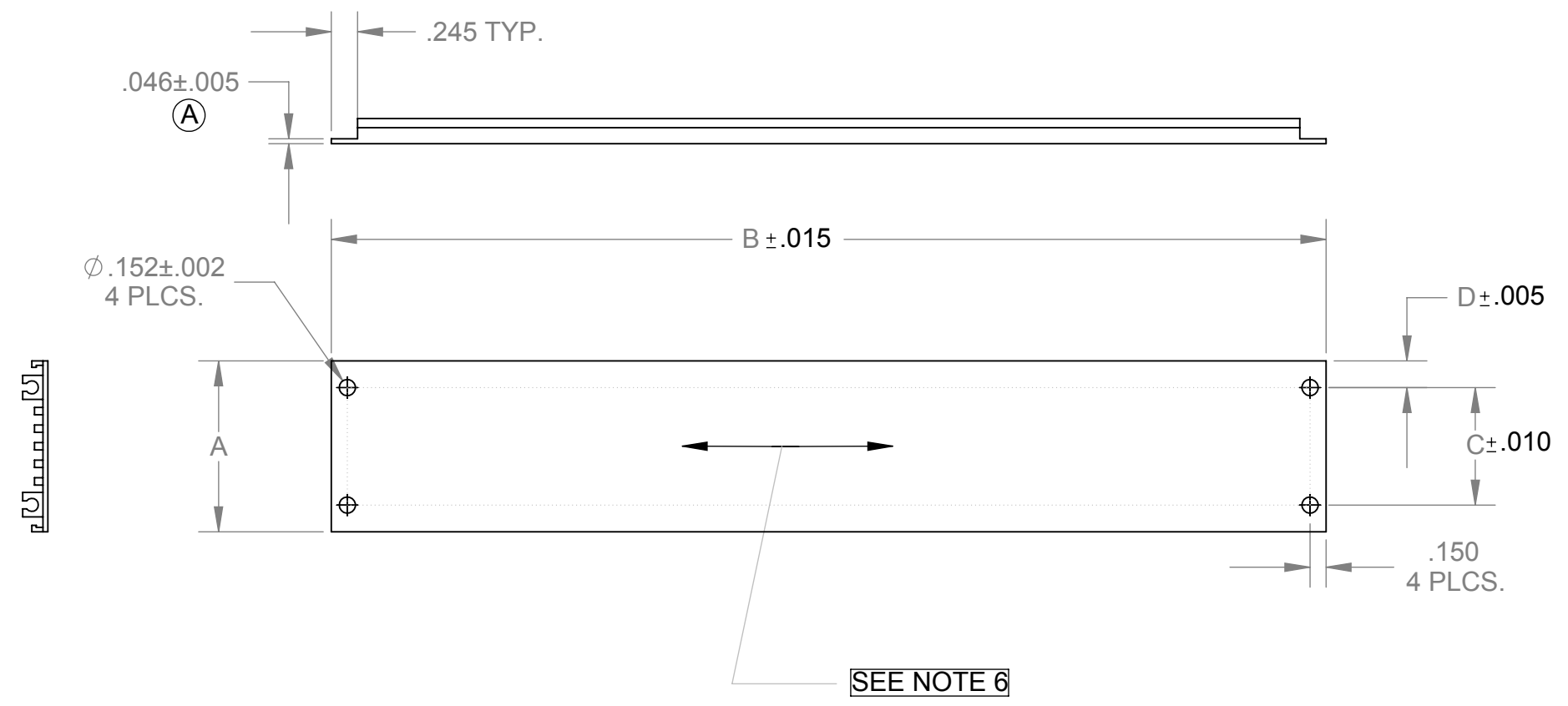

PART NO FINISH: CLEAR ANOD.	MATERIAL P/N NOTE 1	U/O CAT. NO. SER. NOTE 4	PART NO FINISH:NONE	A	B	C	D
SR1-23-3B	SR1-062	W10-23-38B	SR1-23-3B-0	1.000	2.310	0.546	0.227
SR16-12-3B	SR16-02	W16-12-12B	SR16-12-3B-0	1.600	1.210	1.100	0.250
SR16-28-3B	SR16-02	W16-28-46B	SR16-28-3B-0	1.600	2.850	1.100	0.250
SR16-31-3B	SR16-02	W16-31, -31B, -21B	SR16-31-3B-0	1.600	3.100	1.100	0.250
SR16-46-3B	SR16-02	W16-46-31B	SR16-46-3B-0	1.600	4.610	1.100	0.250
SR2-15-3B	SR2-062	W20-15-15B	SR2-15-3B-0	2.000	1.510	1.500	0.250
SR2-28-3B	SR2-062	W20-28, -46B, -15B	SR2-28-3B-0	2.000	2.850	1.500	0.250
SR2-31-3B	SR2-062	W20-31, -42B, -31B	SR2-31-3B-0	2.000	3.100	1.500	0.250
SR2-46-3B	SR2-062	W20-46-31B, -46B, -62B, -66B	SR2-46-3B-0	2.000	4.610	1.500	0.250
SR2-61-3B	SR2-062	W20-61-36B	SR2-61-3B-0	2.000	6.110	1.500	0.250
SR2-66-3B	SR2-062	W20-66-46B	SR2-66-3B-0	2.000	6.610	1.500	0.250
SR1-82-3B	SR1-062	51 x 3	SR1-82-3B-0	1.000	8.214	0.546	0.227
SR3-46-3B	SR3-062	W30-46-46B	SR3-46-3B-0	3.000	4.610	2.500	0.250
SR3-66-3B	SR3-062	W30-66-46B	SR3-66-3B-0	3.000	6.610	2.500	0.250
SR3-86-3B	SR3-062	W30-86-46B	SR3-86-3B-0	3.000	8.610	2.500	0.250
SR3-100-3B	SR3-062	W30-10-46B, -66B	SR3-100-3B-0	3.000	10.000	2.500	0.250
SR45-28-3B	SR45-062	W45-28-21B	SR45-28-3B-0	4.500	2.850	4.000	0.250
SR45-46-3B	SR45-062	W45-46-21B	SR45-46-3B-0	4.500	4.610	4.000	0.250
SR45-66-3B	SR45-062	W45-66-46B	SR45-66-3B-0	4.500	6.610	4.000	0.250
SR45-86-3B	SR45-062	W45-86-46B	SR45-86-3B-0	4.500	8.610	4.000	0.250
SR45-10-3B	SR45-062	W45-10-46B	SR45-10-3B-0	4.500	10.000	4.000	0.250
		U/O SPEC. 4091	M4906-11-1	1.600	5.000	1.100	0.250
		U/O SPEC. 4439	M4906-11-2	1.000	4.610	0.546	0.227

SEE NOTE 6

ALSO SEE CUST B/P (FINISH REF. : CLEAR IRID.)

- 6. THIS SURFACE TO BE POLISHED FOR GRAIN BEFORE PLATING
- 5. DIM A = STD. MAT'L WIDTH
B = CASE "U" - FRAME WIDTH
C = A - 2D
- 4. FOR ASS'Y SEE DWG. MC4906-D3.9
- 3. PART TO BE DEGREASED AFTER FABRICATION
- 2. PARTS TO BE FREE OF EXCESSIVE BURS & SURFACE SCRATCHES
- 1. MAT'L: ALUM. EXTRUSION (6063-T5) DWG. M4211-C5.11
FOR MAT'L P/N SEE TABLE

NOTES: UNLESS OTHERWISE SPECIFIED.

PROPRIETARY AND CONFIDENTIAL
THE INFORMATION CONTAINED IN THIS DRAWING IS THE SOLE PROPERTY OF VECTOR ELECTRONICS & TECH., INC. ANY REPRODUCTION IN PART OR AS A WHOLE WITHOUT THE WRITTEN PERMISSION OF VECTOR ELECTRONICS & TECH., INC. IS PROHIBITED.

UNLESS OTHERWISE SPECIFIED:	NAME	DATE
DIMENSIONS ARE IN INCHES	DRAWN	TRUSHAR 07/22/08
TOLERANCES:	CHECKED	
FRACTIONAL ±	ENG APPR.	
ANGULAR: ± 5°	MFG APPR.	
TWO PLACE DECIMAL ±.03	Q.A.	
THREE PLACE DECIMAL ±.010		
INTERPRET GEOMETRIC TOLERANCING PER:		
MATERIAL 1	THIRD ANGLE PROJECTION	
FINISH		
DO NOT SCALE DRAWING		

VECTOR ELECTRONICS & TECHNOLOGY, INC.		11115 VANOWEN ST., NORTH HOLLYWOOD, CA 91605	
BASE PLATE			
SR.....-3B SER.			
SIZE DWG. NO.	B	REV	B1
M4906-D5.11			
SCALE: 1:2	WEIGHT:	SHEET 3 OF 3	