

→ FBK04F (40mm)

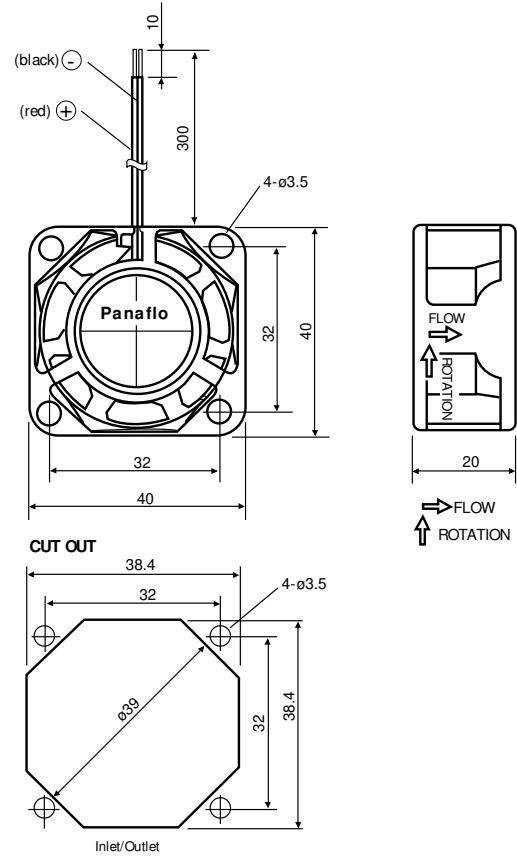

Features

- Operating Temperature: -10°C — +70°C (65% RH)
- Storage Temperature: -40°C — +75°C (65% RH)
- Bearing Type: Ball
- Locked rotor protection and auto-start function
- Lower circuit noise
- Optional third lead wire signal (Locked rotor alarm sensor)

Basic Data (nominal at room temperature)

	Rated Voltage (V)	Operating Voltage (V)	Rated Current (mA)	Rated Input (W)	Nominal Speed (r/min)	Maximum Air Flow		Maximum Air Pressure		Noise (dB-A)
						(m3/min)	(CFM)	(mmH ₂ O)	(Pa)	
FBK04F05L	5	4.5— 6.0	120	.060	4700	0.11	3.9	2.50	24.5	24.0
FBK04F05H	5	4.5— 6.0	280	1.40	7500	0.19	6.7	6.60	64.7	33.0
FBK04F12L	12	7.0— 13.8	75	0.90	4700	0.11	3.9	2.50	24.5	23.0
FBK04F12H	12	7.0— 13.8	150	1.80	7500	0.19	6.7	6.60	64.7	32.0
FBK04F12U	12	7.0— 13.8	170	2.04	9500	0.26	9.2	12.00	117.7	42.0
FBK04F24H	24	14.0— 27.6	92	2.21	7500	0.19	6.7	6.60	64.7	33.0
FBK04F24U	24	14.0— 27.6	100	2.40	9500	0.26	9.2	12.00	117.7	42.0

FBK04F (40mm)

Characteristics

All dimensions in mm.

Lead Wire

All lead wires are 300mm in length \pm 15 mm. (bare wire 10mm \pm 5mm.)

Housing and Fan Blade: Plastic (PET, PBT)

Size

40.0 x 40.0 x 20.0
(1.57 x 1.57 x 0.79)

Weight

40 grams (1.41 ounces)

Case Quantity:

150 per box

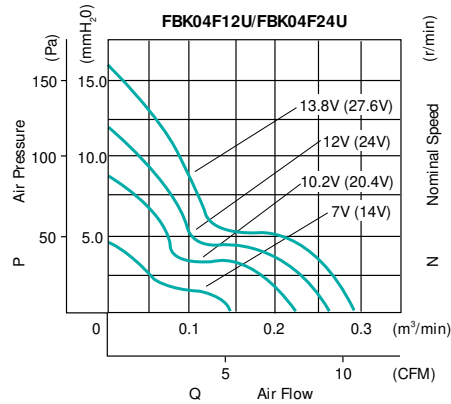
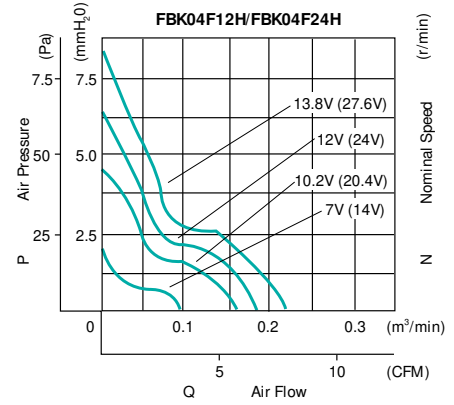
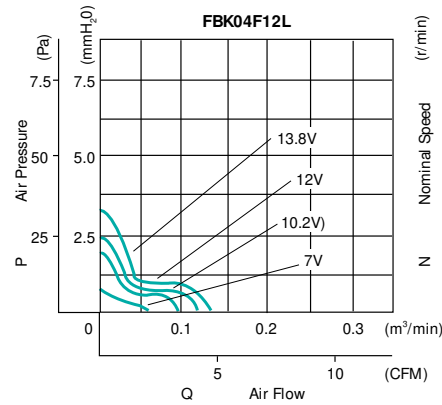
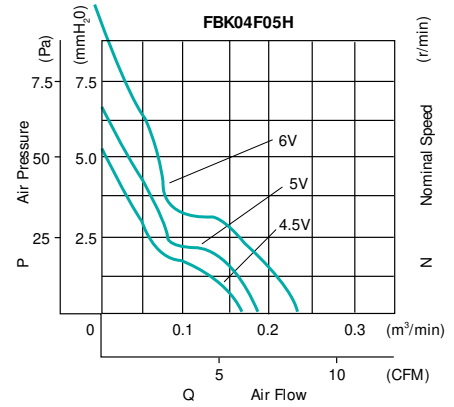
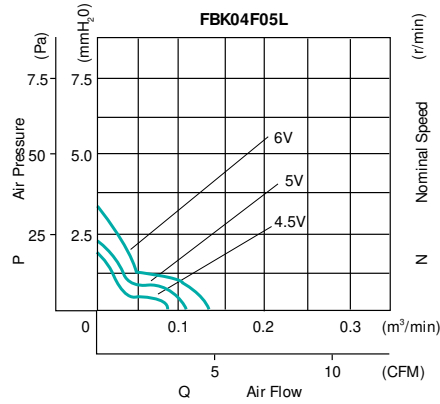

— P— Q

Conversion Factors

1 mm H₂O = 9.8 PA

1 m³/min = 35.313 CFM