



QUARTER TURN - SPRING CAM



*Example with cam. Cam sold separately.

Specifications

- Material:
 - Housing: Zinc Alloy (Zamak) DIN-EN 1774-ZnAl4Cu1
 - Cylinder: Zinc Alloy (Zamak) DIN-EN 1774-ZnAl4Cu1
 - Gasket: Rubber
 - Finish: Chrome

Features

- Spring-loaded cam provides push-to-close action
- Distance between inside of lock face and front of cam fixed at 22.5 mm
- There is no IP 65 version of this lock, due to spring loaded cam
- Applications: Electric panels, machinery covers

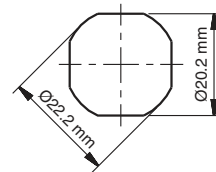
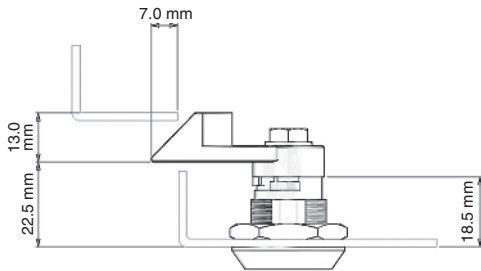
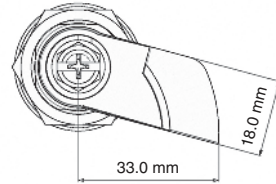
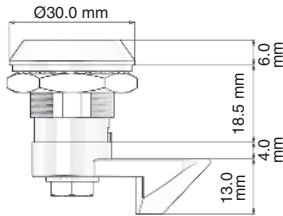

Cut Out

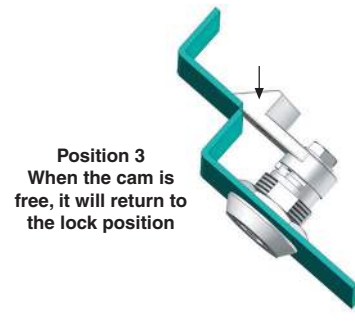
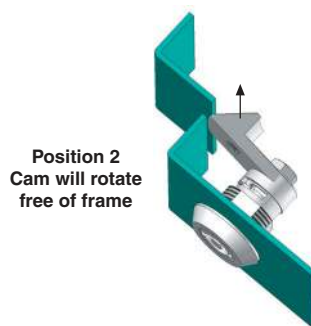
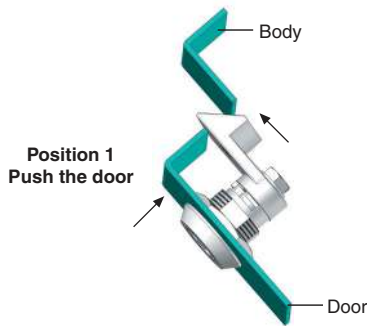

Driver/Head Style



3mm Double Bit

Item Number	Zinc Alloy / Chrome	Zinc Alloy / Black	Nylon / Black	Driver
06011300	06011300	060121300	060201300	3mm Double Bit

Item Number	Zinc Alloy / Chrome	Driver	Hand
160113001	160113001	3mm Double Bit	Right
160113002	160113002	3mm Double Bit	Left