

LOC		DIST		REVISIONS			
P	LTR	DESCRIPTION	DATE	DN	APVD		
D1		REVISED PER ECO-11-005140	28MAR11	RK	HMR		

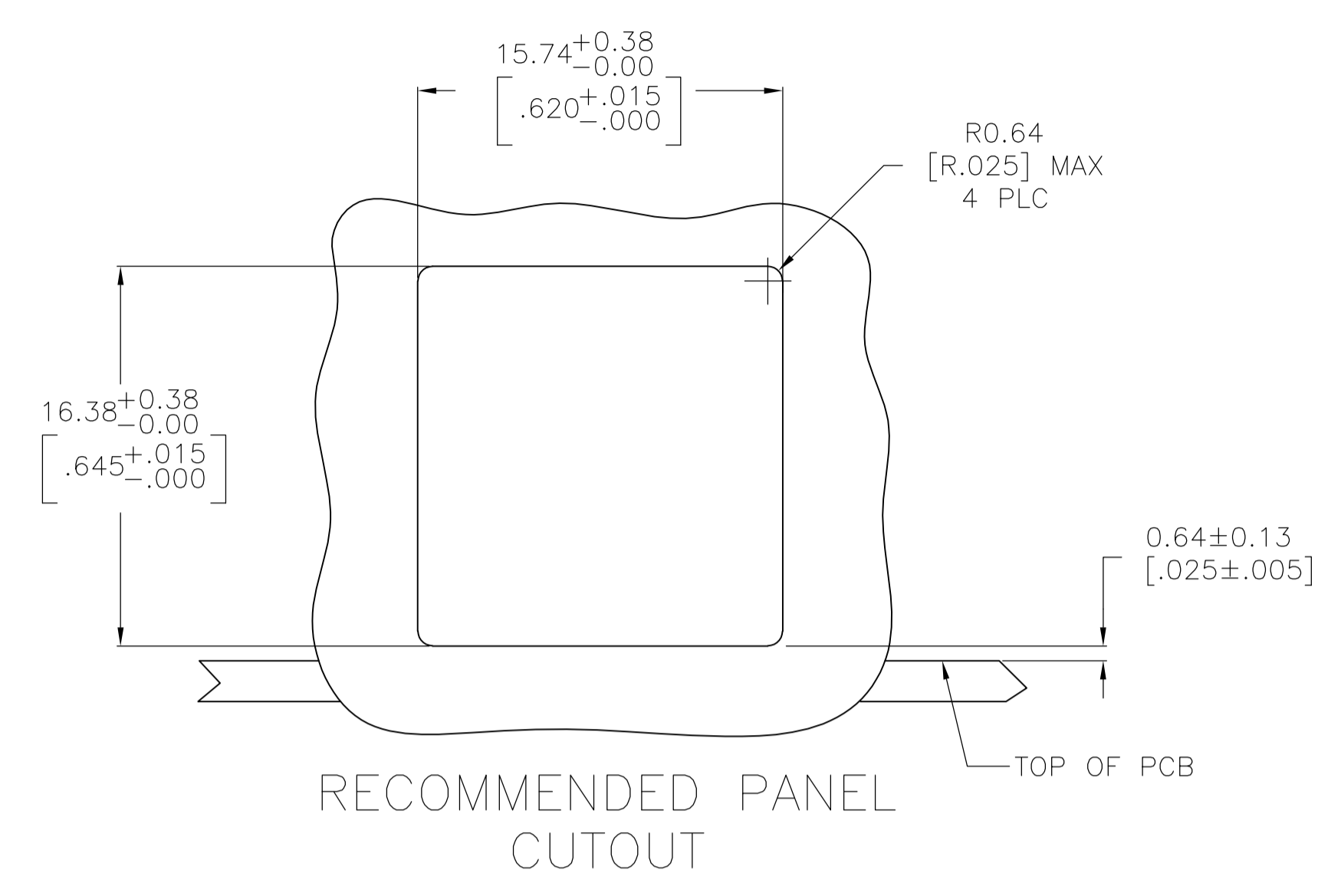

- MATERIAL: HOUSING - PBT POLYESTER, BLACK.  
TERMINAL - PHOS-BRONZE PLATED WITH .000050 [1.27 μm] THICK HARD GOLD IN LOCALIZED GOLD PLATE AREA AND .000080 [2.03 μm] MIN THICK MATTE TIN IN SOLDER AREA OVER .000050 [1.27 μm] MIN THICK NICKEL UNDERPLATE.
- CAVITY CONFORMS TO FCC RULES AND REGULATIONS PART 68 AND REA BULLETIN 345-81, PE-76 SPECIFICATION FOR MODULAR TELEPHONE HARDWARE.
- BULK PACKAGED IN A TRAY.

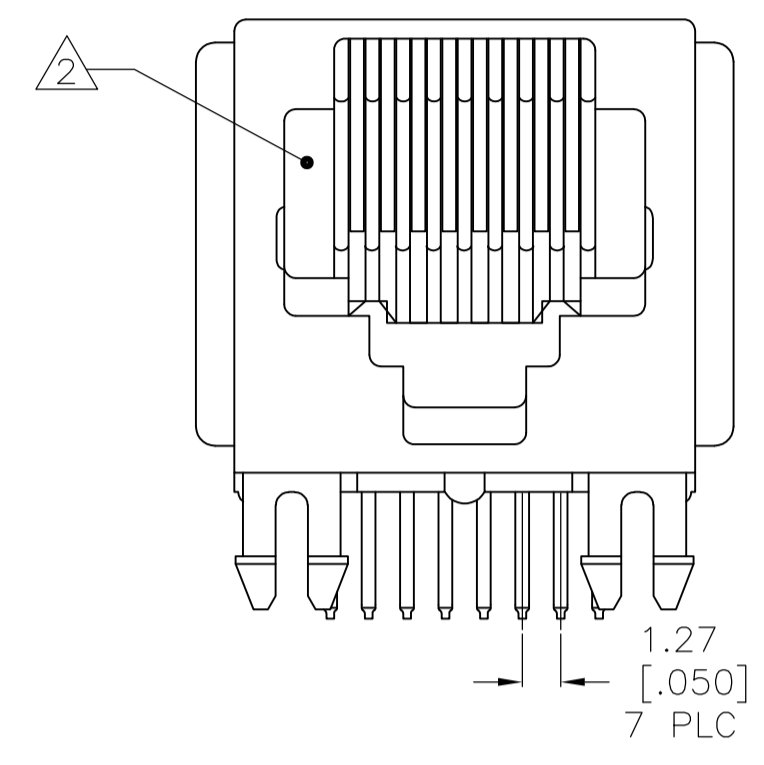
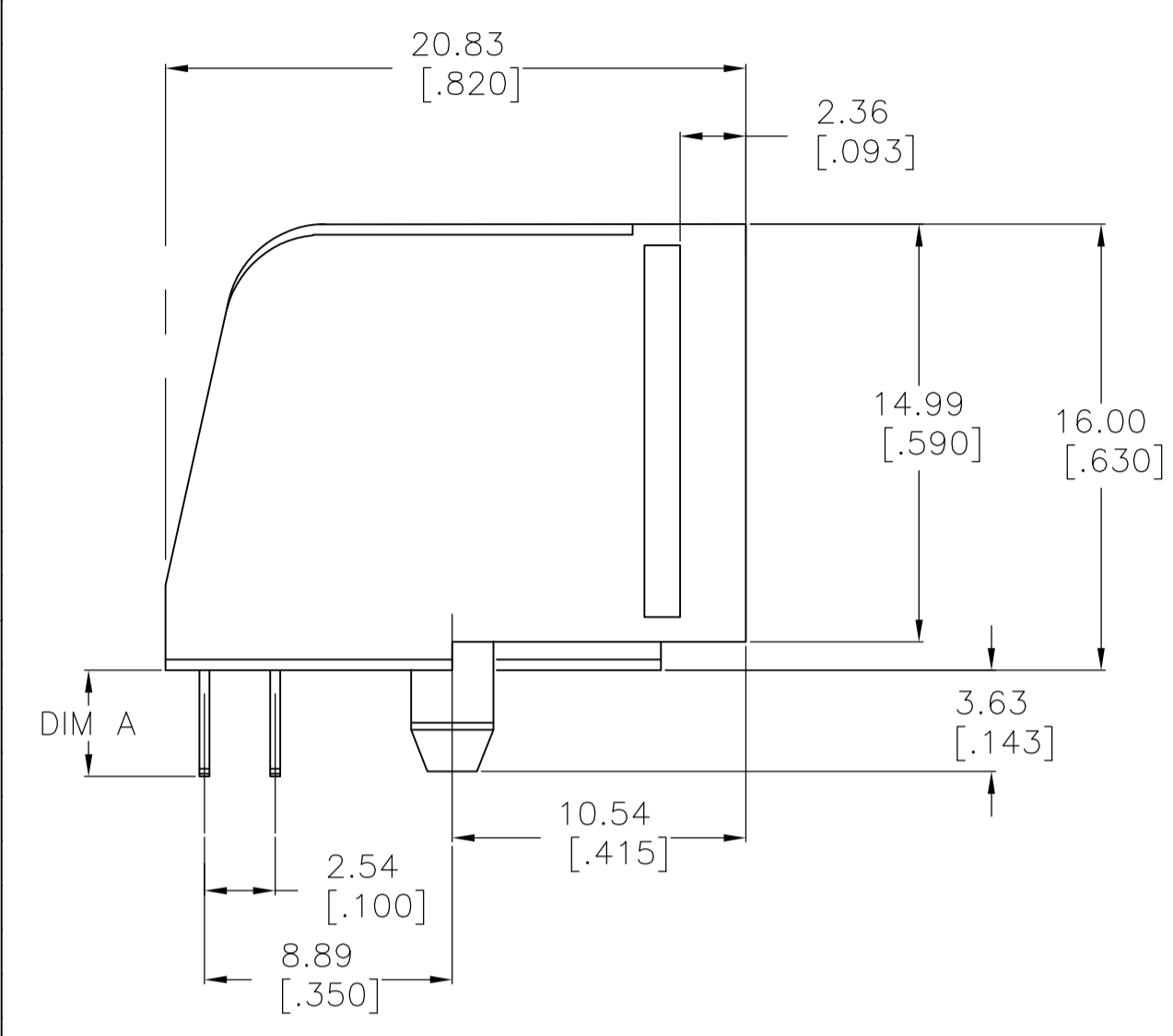
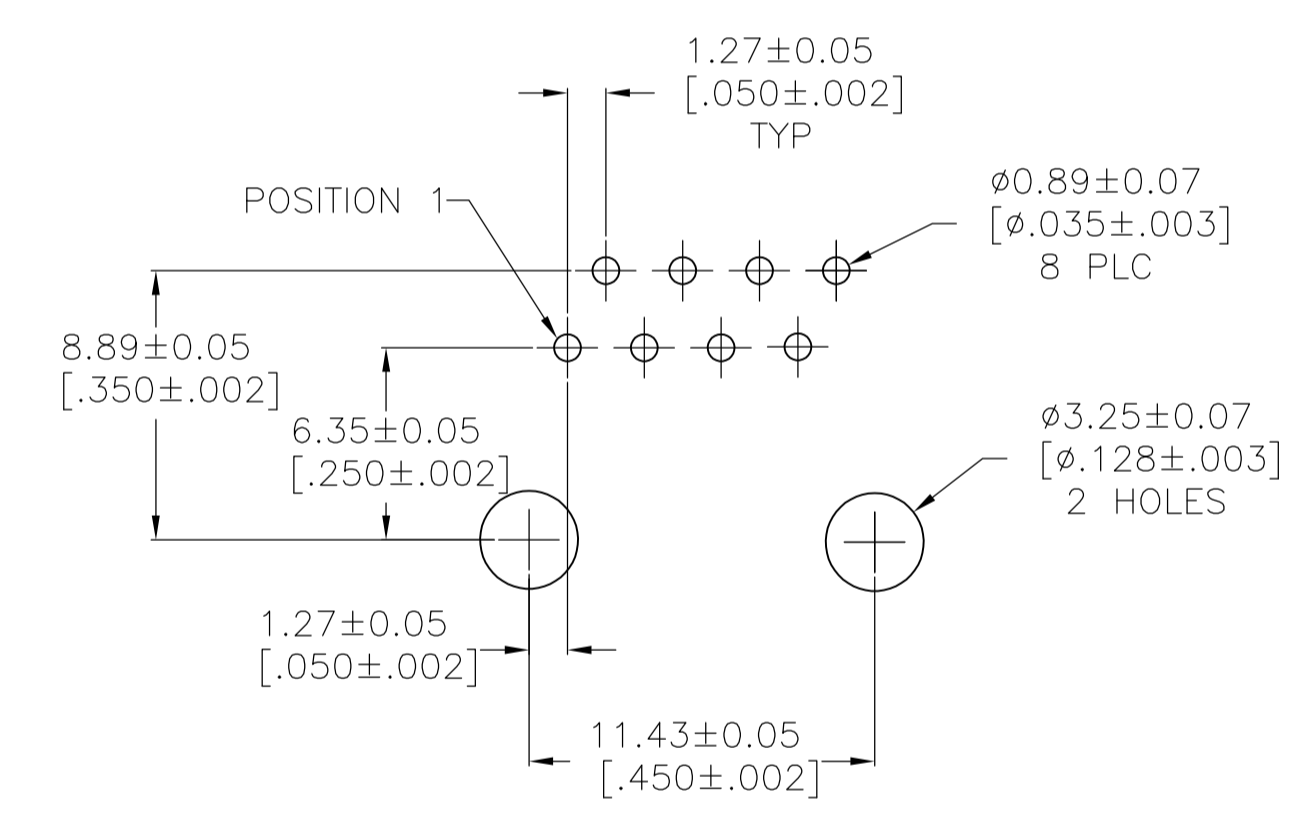
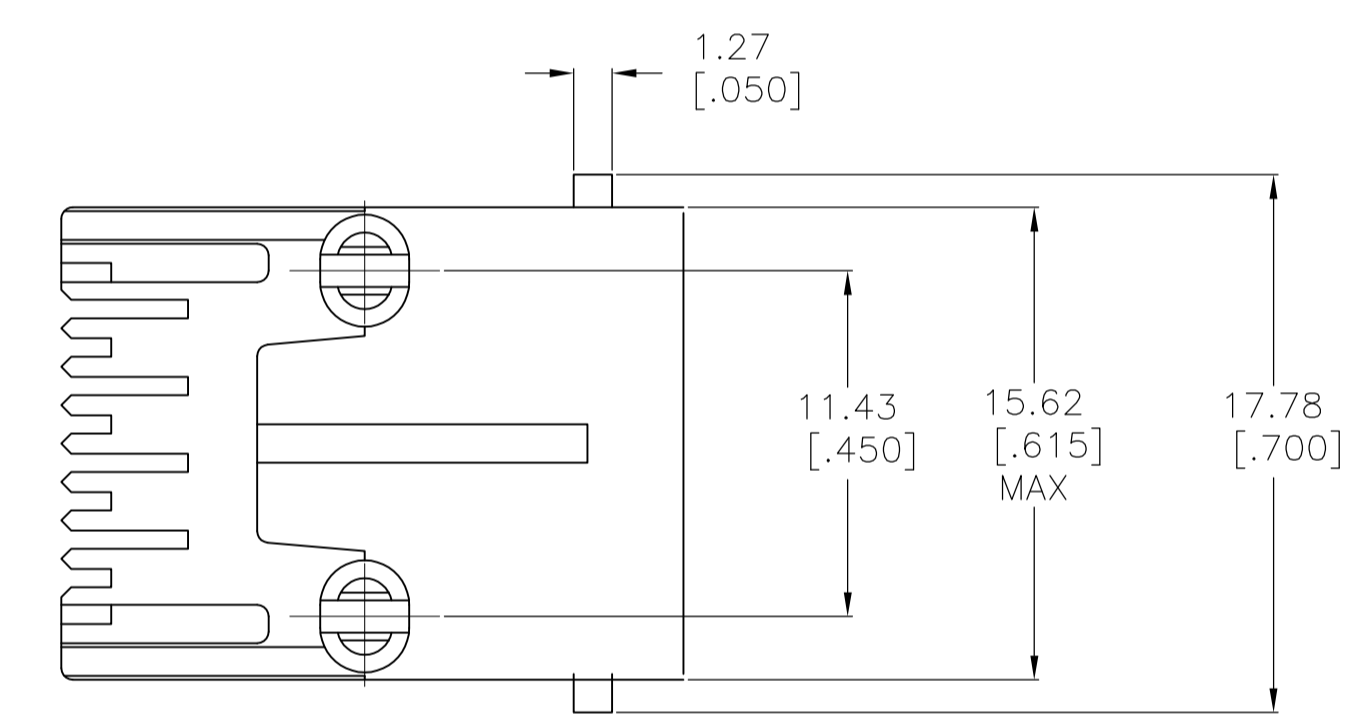

RECOMMENDED PRINTED CIRCUIT BOARD LAYOUT COMPONENT SIDE SHOWN

SUPERSEDED BY 5520251-4	.10-.12[2.54-3.05]	3	8	5520251-9
	.13-.17[3.30-4.32]	3	8	5520251-4
	DIM A	PACKAGED	TERMINALS	PART NUMBER

THIS DRAWING IS A CONTROLLED DOCUMENT.		DIN G. GARRETT/L.A. MAYER 08JUNE2005 C/K J.WESTMAN 4-23-95		TE Connectivity	
DIMENSIONS: mm [INCHES]		TOLERANCES UNLESS OTHERWISE SPECIFIED:		APVD S. FLICKINGER 08JUNE2005 NAME	
0 PLC ± -		1 PLC ± -		PRODUCT SPEC 108-1163	
2 PLC ± -		3 PLC ± .005(.013)		APPLICATION SPEC 114-2048	
4 PLC ± -		ANGLES ± -		SIZE CAGE CODE DRAWING NO RESTRICTED TO	
MATERIAL SEE NOTE 1		FINISH SEE NOTE 1		WEIGHT - A1 00779 C=5520251	
		CUSTOMER DRAWING		SCALE 4:1 SHEET 1 OF 1 REV D1	