

# 320 Watts

## SDC Series



- High Power Density
- Single & Dual Outputs
- Up to 700 W Peak Power
- Fan Fail & Power Good Signals
- Low Leakage Current Option
- Fits 1U Applications
- 3 Year Warranty

## Specification

### Input

Input Voltage	• 90-132 VAC/180-264 VAC
Input Frequency	• 47-63 Hz
Input Current	• 7 A at 90 VAC, 3 A at 230 VAC
Inrush Current	• Max 70 A at 230 VAC, 35 A at 115 VAC, cold start
Power Factor	• EN61000-3-2 class A
Earth Leakage Current	• <500 $\mu$ A at 264 VAC/50 Hz
Input Protection	• T8 A/250 V fuse

### Output

Output Voltage	• See tables
Output Voltage Trim	• $\pm$ 5% on V1 (V2 of dual output models will track by same % of adjustment)
Initial Set Accuracy	• $\pm$ 1%
Minimum Load	• 1% on single output models, 10% on both output of dual output models in order to maintain ripple & noise and regulation specifications
Start Up Delay	• 1.5 s max at 120 VAC
Start Up Rise Time	• 50 ms typical
Hold Up Time	• 20 ms min at 80% of full load
Line Regulation	• $\pm$ 0.5%
Load Regulation	• $\pm$ 1% 1-100% load for single outputs, $\pm$ 3% V1, $\pm$ 7% V2 for dual outputs (except AD0548 version: $\pm$ 11% on V2)
Over/Undershoot	• 5% max
Transient Response	• $\pm$ 5% max deviation, recovery to within 1% in 500 $\mu$ s for a 50% load change
Ripple & Noise	• 1% pk-pk (see note 3)
Overvoltage Protection	• <130% on V1 recycle AC input to reset
Overtemperature	• Measured internally auto recovery
Overload Protection	• 110-140%
Short Circuit Protection	• Trip & restart, auto recovery
Fan Supply	• 12 V/300 mA, not available on '-F' & '-E' versions with built-in fans

### General

Efficiency	• Single output: 5 V: 70%, 12 V: 80%, All other models: >83% at 230 V & full load, Dual Output: >70% at 230 V & full load
Isolation	• 3000 VAC Input to Output, 1500 VAC Input to Ground, 250 VDC Output to Ground
Switching Frequency	• 23 kHz typical single output models, 25 kHz typical dual output models
Power Density	• 8.9 W/In <sup>3</sup>
Signals	• Fan Fail & Power Good
MTBF	• >100 kHrs to MIL-HDBK-217F, at 25 °C GB

### Environmental

Operating Temperature	• 0 °C to +70 °C, derate at 2.5%/°C from +50 °C to +70 °C when force air cooled. 0 °C to +60 °C, derate at 5%/°C from +50 °C to +60 °C when convection cooled.
Storage Temperature	• -20 °C to +85 °C
Operating Humidity	• 5-90%, non-condensing
Cooling	• '-F' & '-E' versions have built-in fans, 5 V single output model requires 22 CFM to meet forced air ratings, all other models require 18 CFM.
Operating Altitude	• 3000 m
Vibration	• 5-50 Hz, acceleration 7.35 ms <sup>2</sup> on 3 axes

### EMC & Safety

Emissions	• EN55032 Level B conducted & radiated
Harmonic Currents	• EN61000-3-2 class A
Voltage Flicker	• EN61000-3-3
ESD Immunity	• EN61000-4-2, level 3 Perf Criteria A
Radiated Immunity	• EN61000-4-3, 3 V/m Perf Criteria A
EFT/Burst	• EN61000-4-4, level 2 Perf Criteria A
Surge	• EN61000-4-5, installation class 3 Perf Criteria A
Conducted Immunity	• EN61000-4-6, 3V Perf Criteria A
Dips & Interruptions	• EN61000-4-11, 30% 10 ms, 60% 100 ms, 100% 5000 ms Perf Criteria A, B, B
Safety Approvals	• EN62368-1, UL62368-1, CSA62368-1 via cUL

**Models and Ratings**

Output Power		Voltage	Output 1			Voltage	Output 2			Model Number
Forced Air Cooled	Convection Cooled		Current				Forced Air	Convection	Peak <sup>(1)</sup>	Auto Ranging Input
			Forced Air	Convection	Peak <sup>(1)</sup>					
225 W	136 W	5 V	45.00 A	27.28 A	140.00 A				SDC320AS05 <sup>(3)</sup>	
260 W	147 W	9 V	29.10 A	16.37 A	77.79 A				SDC320AS09 <sup>(3)</sup>	
320 W	180 W	12 V	26.67 A	15.00 A	58.33 A				SDC320AS12	
320 W	180 W	15 V	21.33 A	12.00 A	46.77 A				SDC320AS15 <sup>(3)</sup>	
320 W	180 W	18 V	17.78 A	10.00 A	38.89 A				SDC320AS18 <sup>(3)</sup>	
320 W	180 W	24 V	13.33 A	7.50 A	29.17 A				SDC320AS24	
320 W	180 W	28 V	11.43 A	6.43 A	25.00 A				SDC320AS28 <sup>(3)</sup>	
320 W	180 W	36 V	8.88 A	5.00 A	19.44 A				SDC320AS36	
320 W	180 W	48 V	6.67 A	3.75 A	14.58 A				SDC320AS48	
320 W	180 W	54 V	5.93 A	3.33 A	12.96 A				SDC320AS54 <sup>(3)</sup>	
320 W	180 W	60 V	5.33 A	3.00 A	11.61 A				SDC320AS60 <sup>(3)</sup>	
250 W	125 W	+5V	30.00 A	15.00 A	36.00 A	+12 V	16.67 A	10.42 A	20.00 A	SDC320AD0512 <sup>(3)</sup>
250 W	125 W	+5V	30.00 A	15.00 A	36.00 A	+24 V	8.33 A	5.20 A	10.00 A	SDC320AD0524 <sup>(3)</sup>
250 W	125 W	+5V	30.00 A	15.00 A	36.00 A	+48 V	4.16 A	2.60 A	5.00 A	SDC320AD0548 <sup>(3)</sup>
300 W	150 W	+12V	16.67 A	12.50 A	20.00 A	+24 V	8.33 A	6.25 A	10.00 A	SDC320AD1224

**Notes**

1. Peak load can be taken for 500 μs. Average power not to exceed nominal power.
2. Ripple & noise is measured using 0.1 μF ceramic capacitor in parallel with 22 μF electrolytic and 20 MHz bandwidth.
3. Available for OEM quantities, contact Sales.

**Mechanical Options**

- Add suffix '-F' to the model number for a top fan cover (forced air cooled ratings apply).
- Add suffix '-E' to the model number for an end fan cover (forced air cooled ratings apply).
- Add suffix '-C' to the model number for a U-channel with vented cover.  
Convection-cooled output power available 125 W for 5 V & 9 V model & 170 W for other single output models.
- Add suffix 'D' to the model number for JST connector, not available on SDC320AS05 for OEM quantities, contact Sales.
- If no suffix is added to the model number the unit is a U-channel, convection-cooled ratings apply or external fan cooling required (22 CFM for 5 V model, 18 CFM for all other models).

**Mechanical Details**

**Enclosed with Top Fan (+F'Option)**

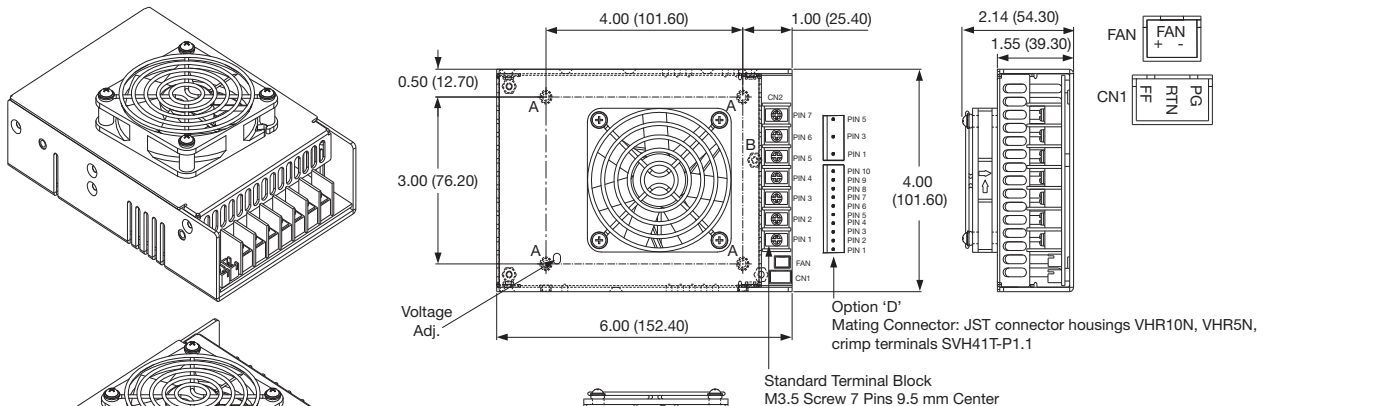

Pin	Standard		JST (Option D)	
	Single	Dual	Single	Dual
1	Vout	Vout1	Vout	Vout1
2	Vout	Rtn	Vout	Vout1
3	Rtn	Rtn	Vout	Vout1
4	Rtn	Vout2	Vout	Rtn
5	Ground	Ground	Vout	Rtn
6	Neutral	Neutral	Rtn	Rtn
7	Live	Live	Rtn	Rtn
8			Rtn	Rtn
9			Rtn	Vout2
10			Rtn	Vout2

Signal Connector mating part is JST XHP-3  
 Crimp terminals SXH-002T-P0.6  
 All dimensions are in inches (mm)  
 Weight: 770 g (1.70 lbs)  
 Tolerance: ±0.012 in (±0.3 mm)

Max screw terminal torque: 15.7 lbs-in (1.8 Nm)  
 Max screw mount hole penetration : 0.16 (4.0)

1		Ground	Ground
3		Neutral	Neutral
5		Live	Live

**Mechanical Details**

**Enclosed with End Fan (±E'Option)**

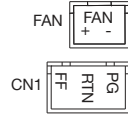
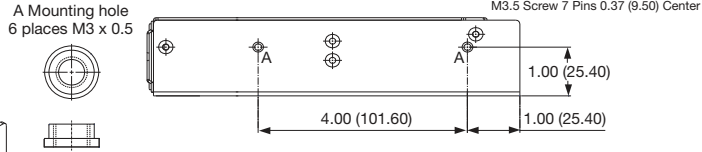
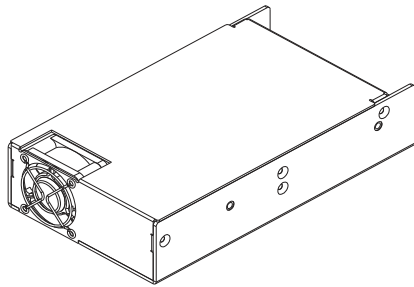
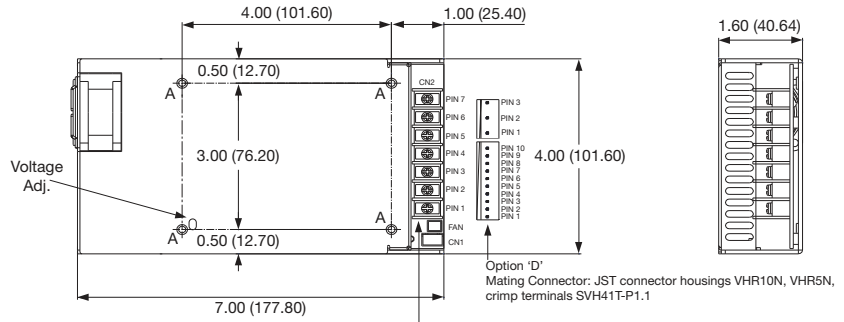
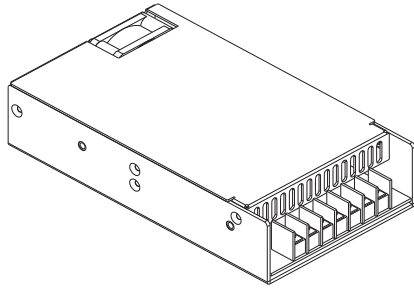

Pin	Standard		JST (Option D)	
	Single	Dual	Single	Dual
1	Vout	Vout1	Vout	Vout1
2	Vout	Rtn	Vout	Vout1
3	Rtn	Rtn	Vout	Vout1
4	Rtn	Vout2	Vout	Rtn
5	Ground	Ground	Vout	Rtn
6	Neutral	Neutral	Rtn	Rtn
7	Live	Live	Rtn	Rtn
8			Rtn	Rtn
9			Rtn	Vout2
10			Rtn	Vout2

1			Ground	Ground
3			Neutral	Neutral
5			Live	Live

Signal Connector mating part is JST XHP-3  
Crimp terminals SXH-002T-P0.6

All dimensions are in inches (mm)  
Weight: 800 g (1.76 lbs)  
Tolerance: ±0.012 in (±0.3 mm)

Max screw terminal torque: 15.7 lbs-in (1.8 Nm)  
Max screw mount hole penetration : 0.16 (4.0)

**U-Channel**

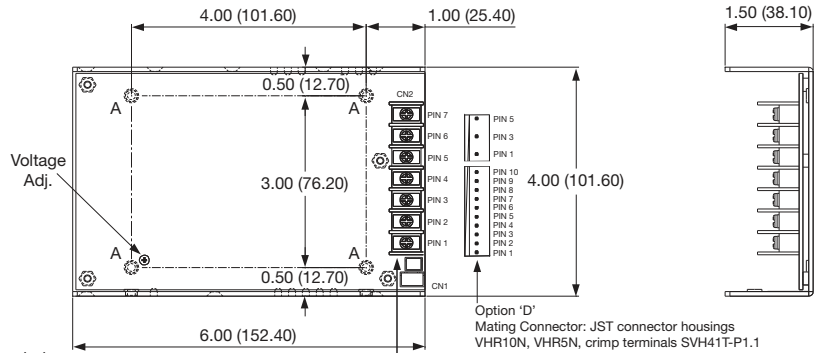
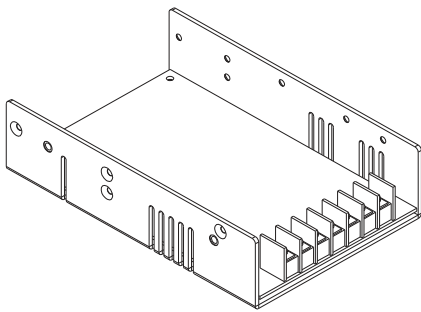

A Mounting hole  
6 places M3 x 0.5

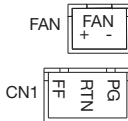

Signal Connector mating part is JST XHP-3  
Fan Connector mating part is JST XHP-2, Crimp terminals SXH-002T-P0.6

All dimensions are in inches (mm)  
Weight: 680 g (1.50 lbs)  
Tolerance: ±0.012 in (±0.3 mm)

Max screw terminal torque: 15.7 lbs-in (1.8 Nm)  
Max screw mount hole penetration : 0.16 (4.0)

# Mechanical Details

## U-Channel with cover (±C'Option)

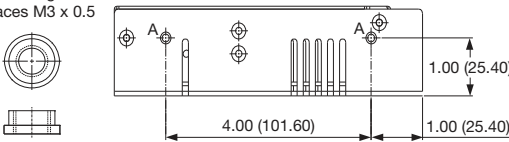
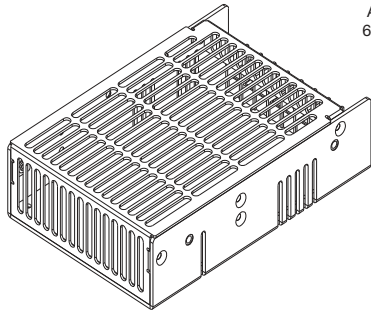
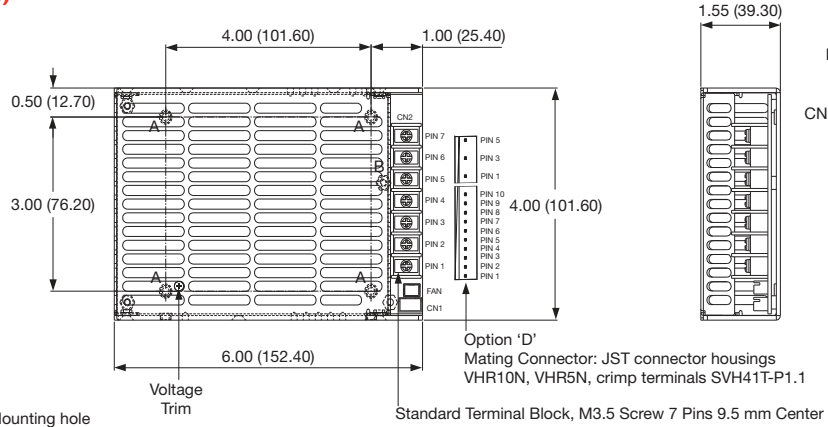
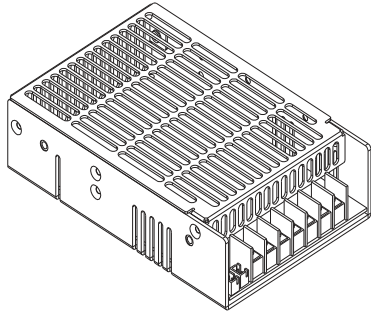

Pin	PIN CONNECTIONS			
	Standard		JST (Option D)	
	Single	Dual	Single	Dual
1	Vout	Vout1	Vout	Vout1
2	Vout	Rtn	Vout	Vout1
3	Rtn	Rtn	Vout	Vout1
4	Rtn	Vout2	Vout	Rtn
5	Ground	Ground	Vout	Rtn
6	Neutral	Neutral	Rtn	Rtn
7	Live	Live	Rtn	Rtn
8			Rtn	Rtn
9			Rtn	Vout2
10			Rtn	Vout2

Signal Connector mating part is JST XHP-3  
 Fan Connector mating part is JST XHP-2, Crimp terminals SXH-002T-P0.6

All dimensions are in inches (mm)  
 Weight: 720 g (1.59 lbs)  
 Tolerance: ±0.012 in (±0.3 mm)

Max screw terminal torque: 15.7 lbs-in (1.8 Nm)  
 Max screw mount hole penetration : 0.16 (4.0)

## Application Notes

### Power Good

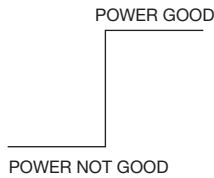
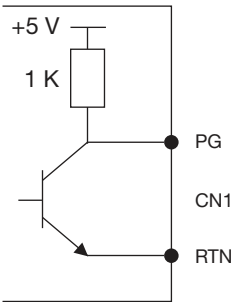

Sink current = 6 mA  
 Source current = 1 mA

### Fan Fail

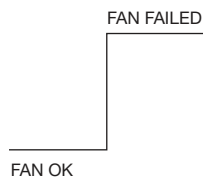
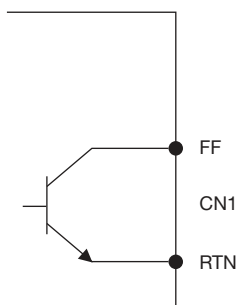

Open collector signal can pull up to 5-28 VDC, limit sink current to 5 mA max