

MAXIM

MAX2235 Evaluation Kit

General Description

The MAX2235 evaluation kit (EV kit) simplifies evaluation of the MAX2235 power amplifier (PA). It enables testing of the device's RF performance and requires no additional support circuitry. The EV kit's signal inputs and outputs use SMA connectors to facilitate the connection of RF test equipment.

The MAX2235 EV kit is assembled with a MAX2235 and incorporates input and output matching components optimized for the 824MHz to 849MHz RF frequency band. All matching components may be changed to work at RF frequencies from 800MHz to 1000MHz.

Component Suppliers

SUPPLIER	PHONE	FAX
ATC	516-622-4700	516-622-4748
Kamaya	219-489-1533	219-489-2261
Murata Electronics	800-831-9172	814-238-0490
Toko	408-432-8281	408-943-9790

Features

- ◆ Easy Evaluation of MAX2235
- ◆ +2.7V to +5.5V Single-Supply Operation
- ◆ RF Input and Output Matched for Operation from 824MHz to 849MHz
- ◆ All Critical Peripheral Components Included

Ordering Information

PART	TEMP. RANGE	IC PACKAGE
MAX2235EVKIT	-40°C to +85°C	20 TSSOP-EP

Component List

DESIGNATION	QTY	DESCRIPTION
C1	1	100pF, 5% ceramic capacitor (0603) Murata GRM39COG101J050V
C2	1	68pF, 5% ceramic capacitor (0603) Murata GRM39COG680J050V
C3, C4	2	1000pF, 10% ceramic capacitors (0603) Murata GRM39X7R102K050V
C5, C6	2	100pF, 5% ceramic capacitors (0402) Murata GRM36COG101J050V
C7	1	22pF, 5% ceramic capacitor (0603) Murata GRM39COG220J050V
C8	1	0.068μF, 10% Murata GRM39X7R683K016V
C9, C10	2	470pF, 10% ceramic capacitors (0603) Murata GRM39X7R471K050V
C11	1	220pF, 5% ceramic capacitor (0603) Murata GRM39COG221J050V
C12	1	1500pF, 10% ceramic capacitor (0603) Murata GRM39X7R152K0504
C13	1	47pF, 5% ceramic capacitor ATC 100A470JW150X

DESIGNATION	QTY	DESCRIPTION
C14	1	11pF, 5% ceramic capacitor ATC 100A110JW150X
C15	1	0.01μF, 10% ceramic capacitor (0805) Murata GRM40X7R103K050V
C16	1	1μF, +80%, -20% ceramic capacitor (1206) Murata GRM42-6Y5V105Z025V
C17, C18	2	1000pF, 10% ceramic capacitors (0805) Murata GRM40X7R102K050V
L1	1	8.2nH (0603) inductor Toko LL1608-FH8N2K
L3	1	30-gauge wire short
J1, J2	2	SMA connectors (PC edge mount) E.F. Johnson 142-0701-801
J3, J4	2	Test points
JU1	1	3-pin header (0.1" centers)
R1	1	0Ω resistor (0603) Kamaya RMC16-000T
VCTRL	1	1-pin header
U1	1	MAX2235EUP (TSSOP-20)
None	1	MAX2235 EV kit PC board

MAX2235 Evaluation Kit

Quick Start

The MAX2235 EV kit is fully assembled and factory tested. Follow the instructions in the *Connections and Setup* section for proper device evaluation.

Test Equipment Required

This section lists the recommended test equipment to verify operation of the MAX2235. It is intended as a guide only, and some substitutions are possible.

- One RF signal generator capable of delivering at least +10dBm of output power at the operating frequency (HP8648C, or equivalent)
- One RF power sensor capable of handling at least +20dBm of output power at the operating frequency (HP8482A, or equivalent)
- One RF power meter capable of measuring up to +20dBm of output power at the operating frequency (HP EPM-441A, or equivalent)
- An RF spectrum analyzer that covers the operating frequency range of the MAX2235 as well as a few harmonics (HP8561E, for example)
- A power supply capable of up to 1A at +2.7V to +5.5V
- An optional ammeter for measuring the supply current
- Two 50Ω SMA cables
- One SMA 20dB pad
- Network Analyzer (HP8753D, for example) to measure small-signal return loss and gain (optional)

Connections and Setup

This section provides a step-by-step guide to operating the EV kit and testing the device's function. **Do not turn on the DC power or RF signal generators until all connections are made.**

- 1) Connect a DC supply set to +3.6V (through an ammeter if desired) to the V_{CC} and GND terminals on the EV kit. **Do not turn on the supply.**

- 2) Connect one RF signal generator to the RFIN SMA connector; do not turn on the generator's output. Set the generator for an output frequency of 836MHz at a power level of 0dBm.
- 3) Connect a 20dB pad to the RFOUT SMA connector on the EV kit. This is to prevent overloading of the power sensor and the power meter.
- 4) Connect a power sensor to the 20dB pad.
- 5) Connect the power sensor to a power meter. Set the power meter offset to 20dB and frequency to 836MHz.
- 6) Turn on the DC supply. The supply current should read approximately 70mA.
- 7) Activate the RF generator's output. The power meter should read approximately +30dBm. The supply-current should increase to approximately 600mA.
- 8) Another method for determining gain is by using a Network Analyzer (optional). This has the advantage of displaying gain versus a swept-frequency band, in addition to displaying input and output return loss. Refer to the Network Analyzer manufacturer's user manual for setup details.

Layout Issues

A good PC board (PCB) is an essential part of an RF circuit design. The EV kit PCB can serve as a guide for laying out a board using the MAX2235. Keep traces carrying RF signals as short as possible to minimize radiation and insertion loss due to the PCB. Each V_{CC} node on the PCB should have its own decoupling capacitor. This minimizes supply coupling from one section of the IC to another. A star topology for the supply layout, in which each V_{CC} node on the circuit has a separate connection to a central V_{CC} node, can further minimize coupling between sections of the IC.

MAX2235 Evaluation Kit

Evaluates: MAX2235

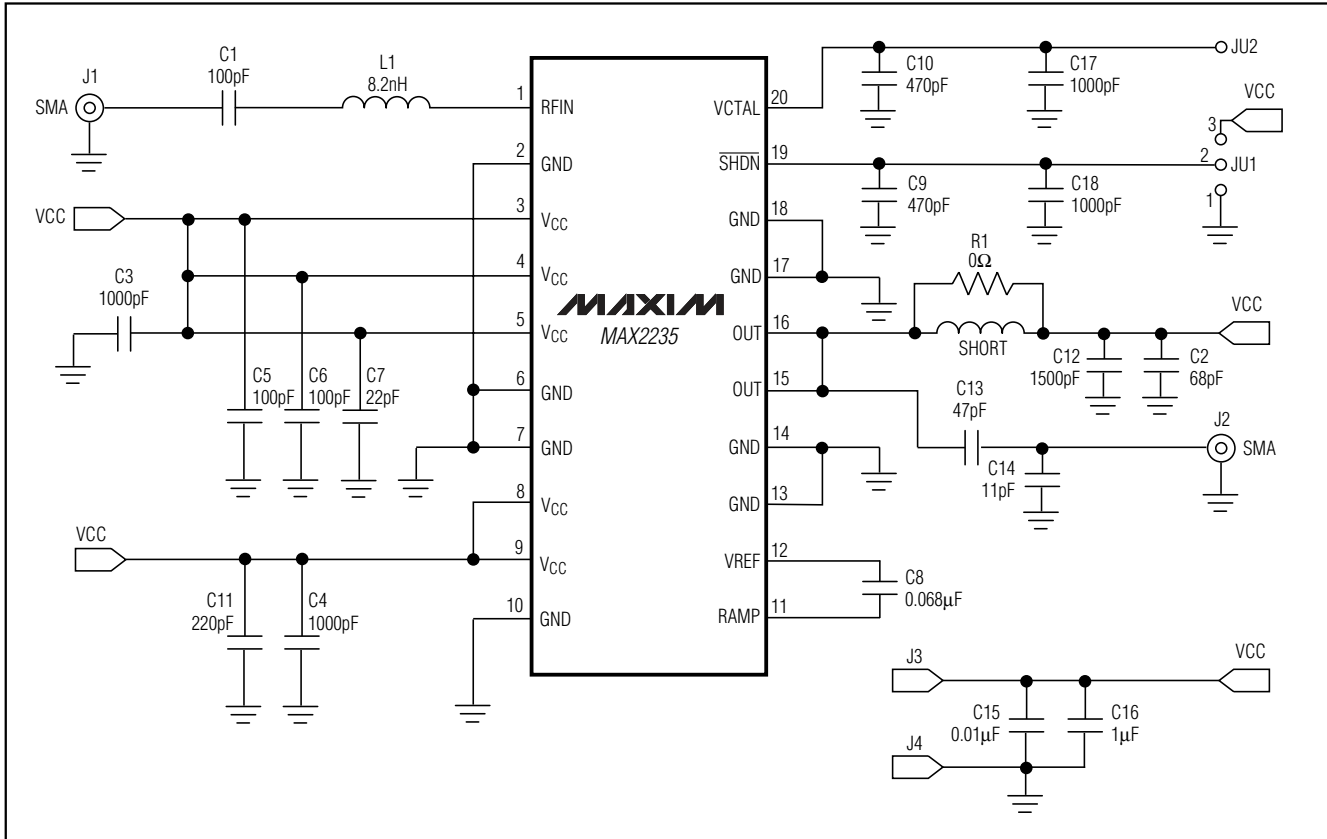

Figure 1. MAX2235 EV Kit Schematic

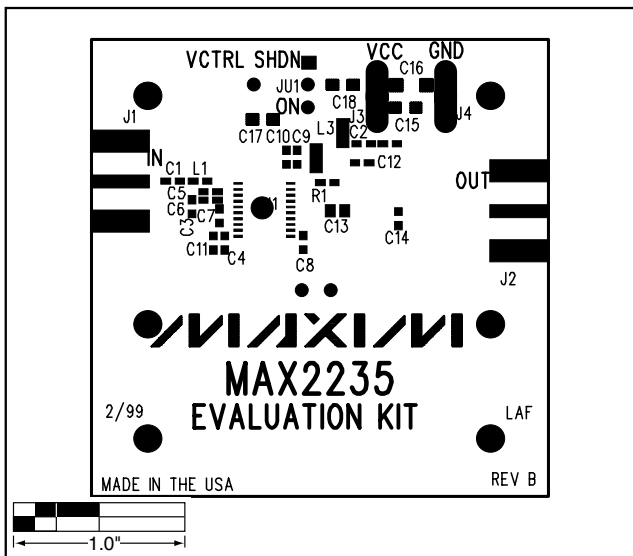

Figure 2. MAX2235 EV Kit Component Placement Guide—Component Side

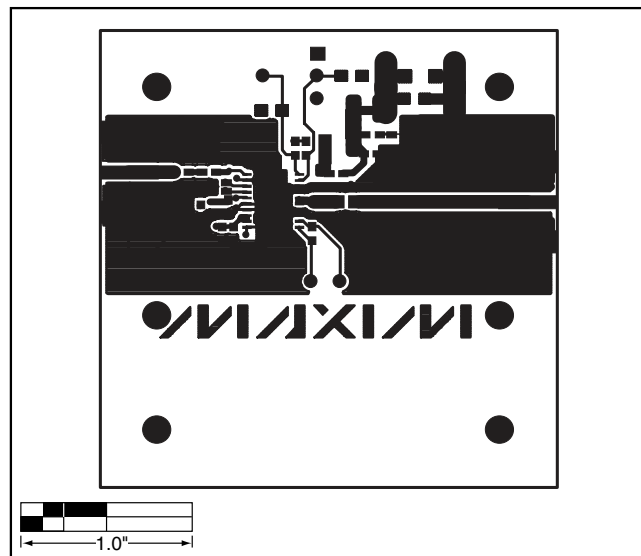

Figure 3. MAX2235 EV Kit PC Board Layout—Component Side

MAX2235 Evaluation Kit

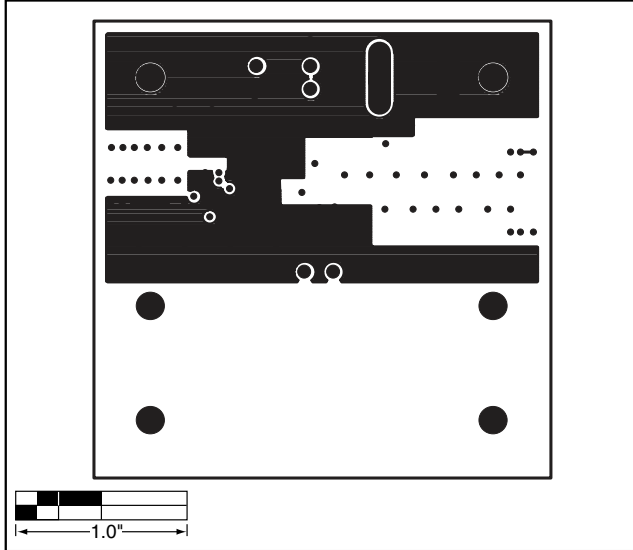

Figure 4. MAX2235 EV Kit PC Board Layout—Ground Plane

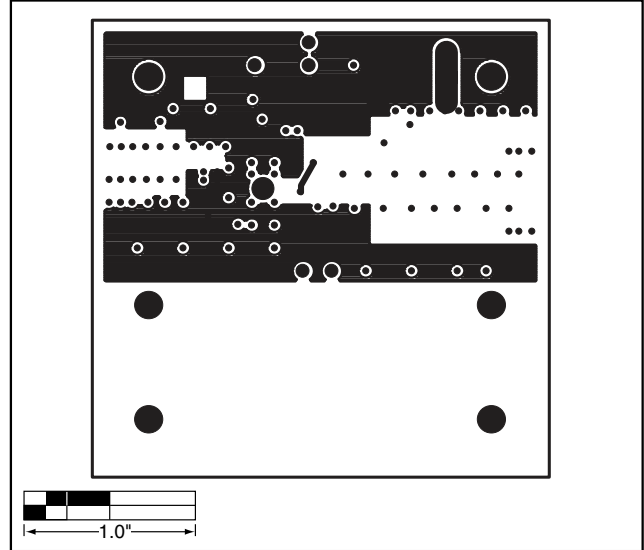

Figure 5. MAX2235 EV Kit PC Board Layout—Power Plane

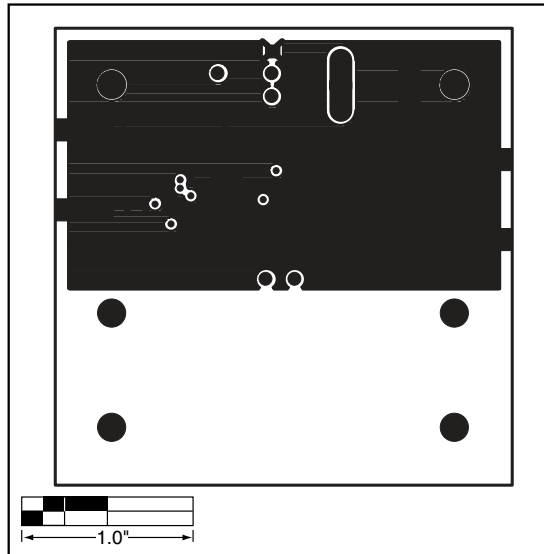

Figure 6. MAX2235 EV Kit PC Board Layout—Solder Side

Maxim cannot assume responsibility for use of any circuitry other than circuitry entirely embodied in a Maxim product. No circuit patent licenses are implied. Maxim reserves the right to change the circuitry and specifications without notice at any time.