



## Test Procedure for the NCP160MXTBGEVB Evaluation Board

There is a collection test procedures for NCP160 demoboards. This paper offers some helpful test configuration for first contact with ONSEMI NCP160 LDO.

### 1. QUIESCENT CURRENT

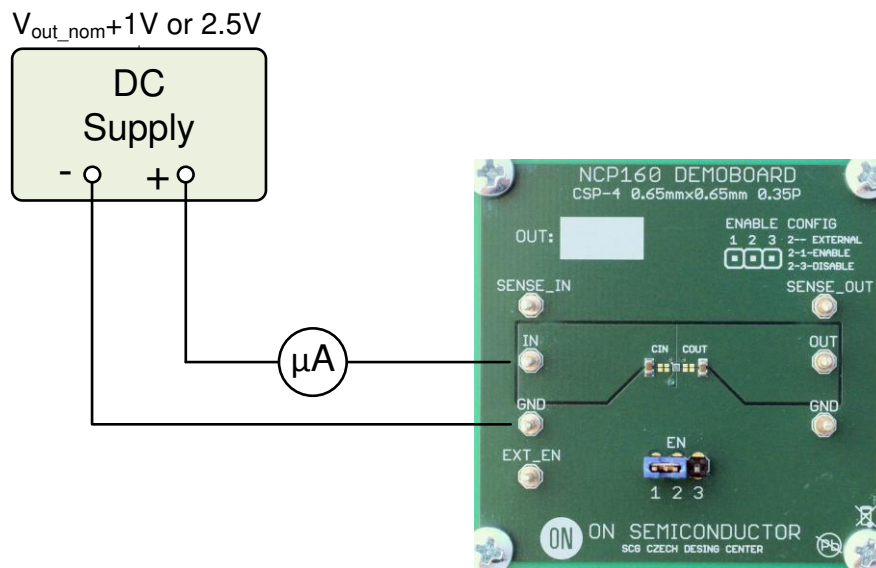

Figure 1: Test configuration for measurement  $I_Q$ , Quiescent Current

1. Connect circuit as shown figure on 1
2. Apply voltage at  $V_{Input}$ . Default test  $V_{Input}$  is  $V_{out\_nom} + 1$  V or 2.5 V whichever is greater
3. Value shown  $\mu A$  meter is measured quiescent current.
4. Measurement is finished. Disconnect supply voltage.

*\*Note – Be carefully if any device is connected on output, because leakage current can affect measurement accuracy.*



## 2. LOAD REGULATION

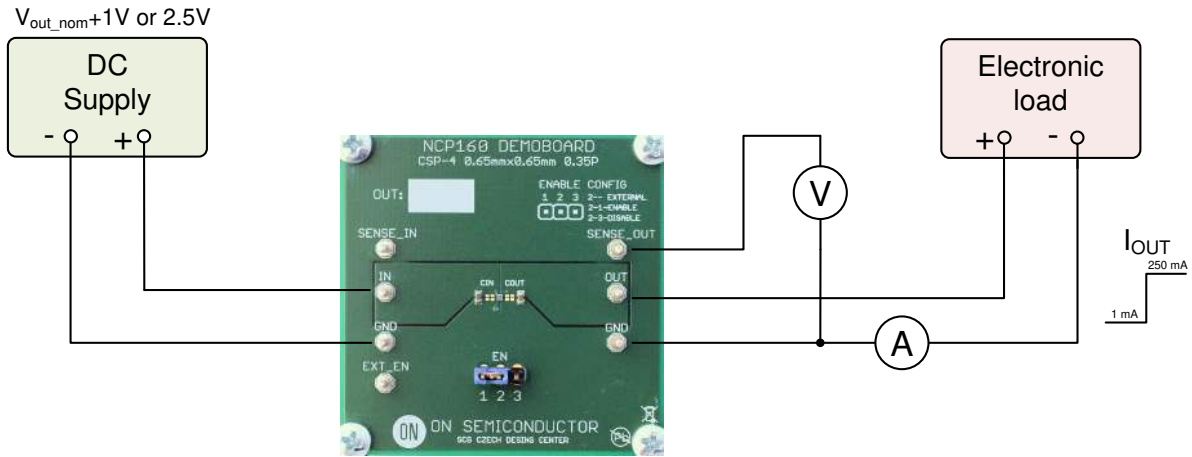

Figure 2: Test configuration for measurement  $REG_{LOAD}$ , Load Regulation

1. Connect circuit as shown figure on 2
2. Apply voltage at  $V_{input}$ . Default test  $V_{input}$  is  $V_{out\_nom}+1$  V or 2.5 V whichever is greater
3. Set minimal required current  $I_1$ , e.g. 1 mA, and switch load ON.
4. Note the value  $V_1$  from voltmeter  $V_o$ .
5. Switch load OFF and set maximal required current  $I_2$ , e.g. 250 mA and switch load ON.
6. Note the value  $V_2$  from voltmeter  $V_o$ .
7. Load regulation is obtained via following formula:  $REG_{LOAD}=(V_1-V_2)$ , [V]
8. Measurement is finished. Disconnect supply voltage.



### 3. LINE REGULATION

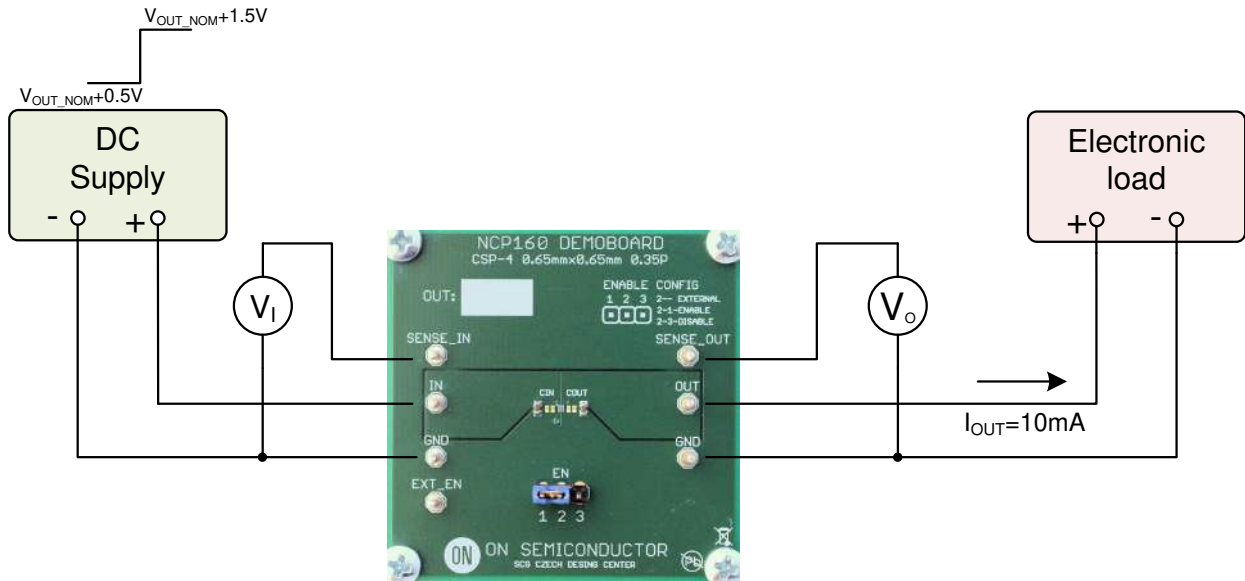

Figure 3: Test configuration for measurement  $REG_{LINE}$ , Line Regulation

1. Connect circuit as shown on figure 3
2. Set load to the required current e.g. 10 mA
3. Set minimal input voltage  $V_{I1}$ ,  $V_{OUT\_NOM}+1V$  or 2.5V whichever is greater
4. Note the value  $V_{I1}$  and  $V_{O1}$ .
5. Set maximal input voltage  $V_{I2} = 5.5 V$
6. Note the value  $V_{I2}$  and  $V_{O2}$ .
7. Load regulation is obtained via following formula:  $REG_{LINE}=(V_{O1}-V_{O2})/(V_{I1}-V_{I2})$ , [V/V]
8. Measurement is finished. Disconnect supply voltage.



#### 4. ENABLE START-UP

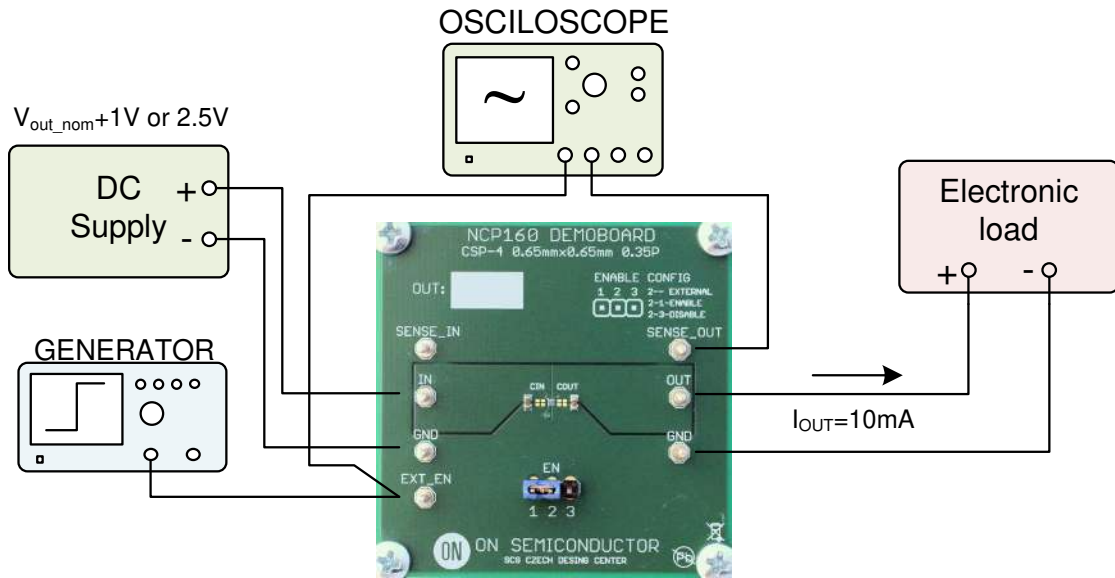

Figure 4: Test configuration for measurement enables response

1. Connect circuit as shown on figure 4
2. Set generator to SQUARE PULSE,  $0.9 \leq \text{AMPLITUDE} \leq V_{IN}$ , FREQUENCY=10Hz, DUTY=10%
3. Apply voltage at  $V_{Input}$ . Default test  $V_{input}$  is  $V_{out\_nom} + 1\text{ V}$  or  $2.5\text{ V}$  whichever is greater
4. Set required  $I_{OUT}$ , e.g. 10 mA
5. Connect oscilloscope to EN signal and  $V_{OUTPUT}$ .
6. Watch enable response of the regulator after asserting EN pin.
7. Measurement is finished. Disconnect supply voltage.