

REVISIONS					
P	LTR	DESCRIPTION	DATE	DMN	APVD
V		REV PER ECO 17-000132	5-1-17	CT	DM

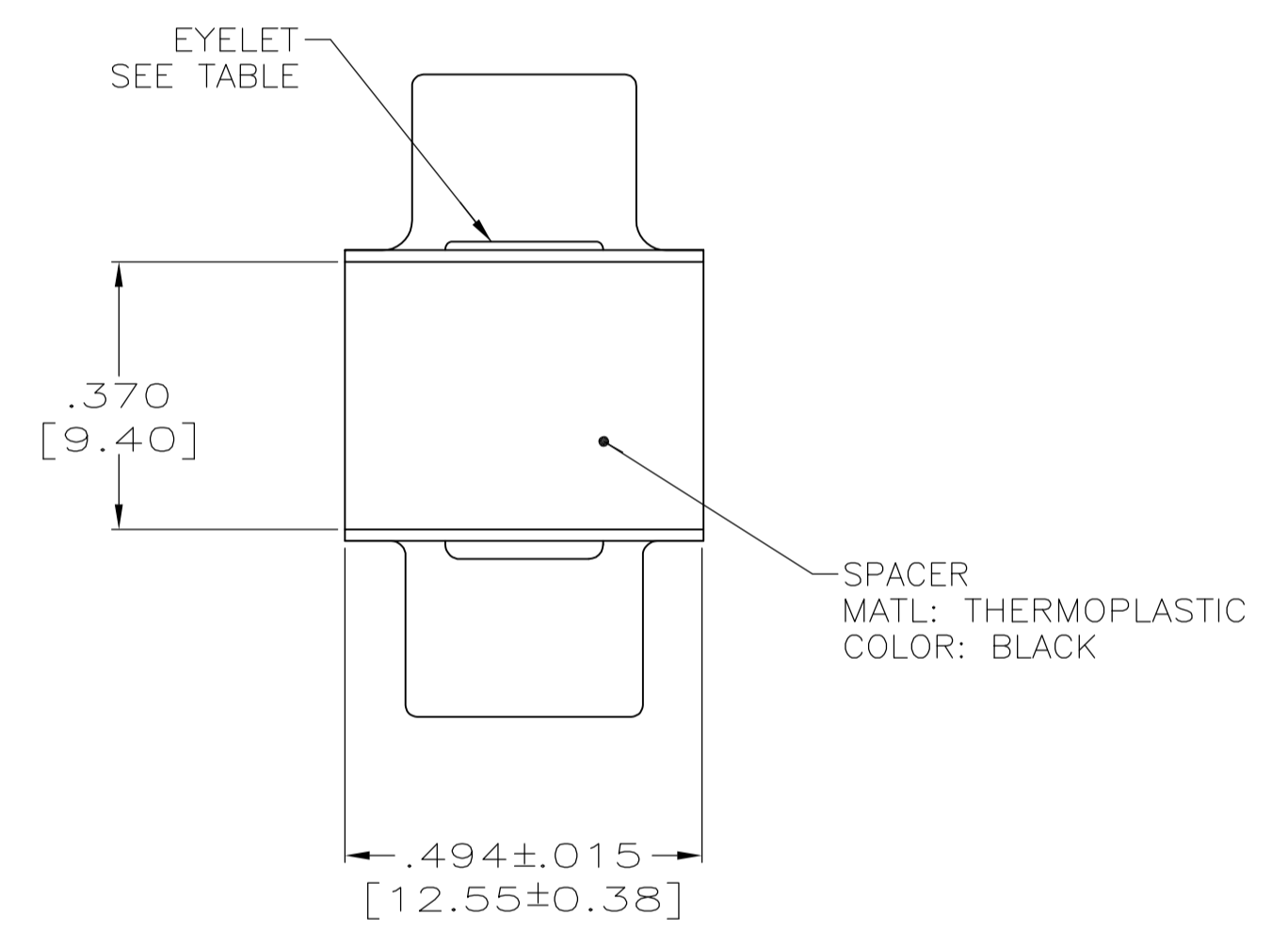

- CONTACTS INCLUDED IN ASSEMBLY.
 - MAT'L: STEEL, PER ASTM-A-109.
 - FINISH: CADMIUM PER QQ-P-416.
 - MAT'L: BRASS PER ASTM-B-36.
 - FINISH: PLATED ZINC .00020 MIN THK PER ASTM-B-633. YELLOW CHROMATE FINISH.
- CONTACT
 - BODY MAT'L: BERYLLIUM COPPER PER ASTM-B-197.
 - BODY FINISH: PLATED GOLD, .000050 MIN THK PER MIL-G-45204 OVER NICKEL, .000050 MIN THK PER QQ-N-290.
 - HOOD MAT'L: STAINLESS STEEL PER ASTM-A-240.
 - HOOD FINISH: PASSIVATED PER QQ-P-35.
 - FINISH: PLATED GOLD, .000050 MIN THK PER MIL-G-45204 OVER COPPER FLASH.
 - FINISH: PLATED GOLD, .000050 MIN THK PER MIL-G-45204 OVER COPPER, .000100 MIN THK PER MIL-C-14550.
 - CONTACT
 - BODY MAT'L: BERYLLIUM COPPER PER ASTM-B-197.
 - BODY FINISH: PLATED GOLD, .000050 MIN THK PER MIL-G-45204 OVER COPPER, .000100 MIN THK PER MIL-C-14550.
 - HOOD MAT'L: COPPER ALLOY PER QQ-B-613.
 - FINISH: PLATED GOLD, .000050 MIN THK PER MIL-G-45204 OVER COPPER, .000100 MIN THK PER MIL-C-14550.

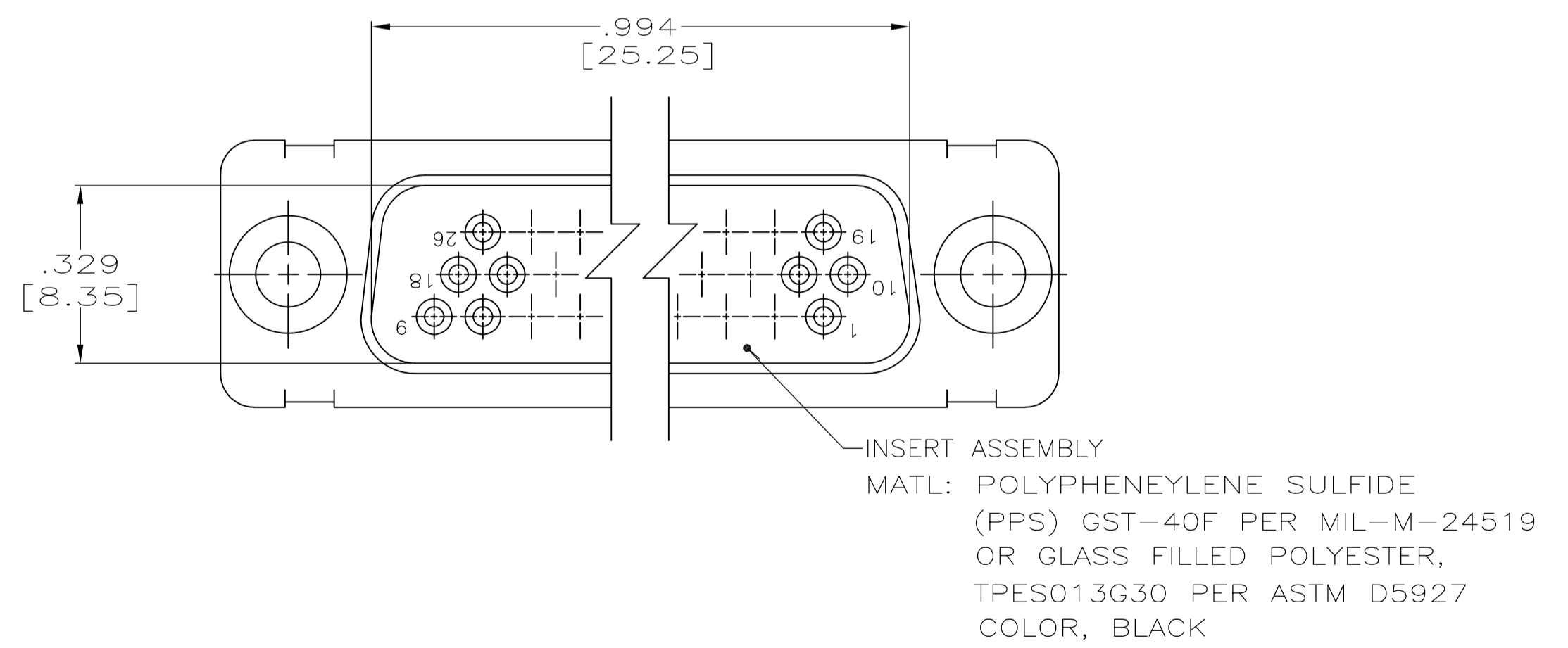
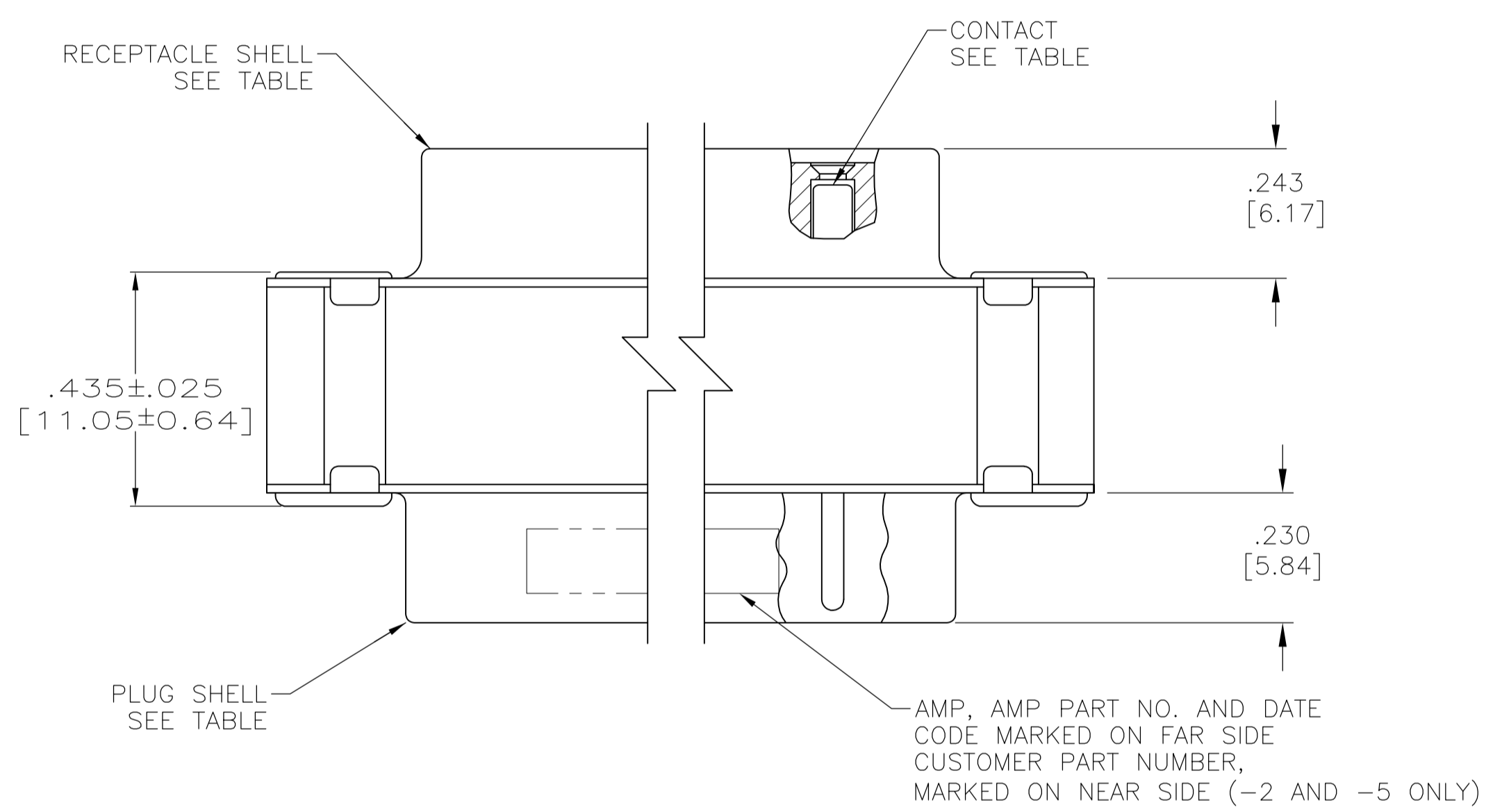
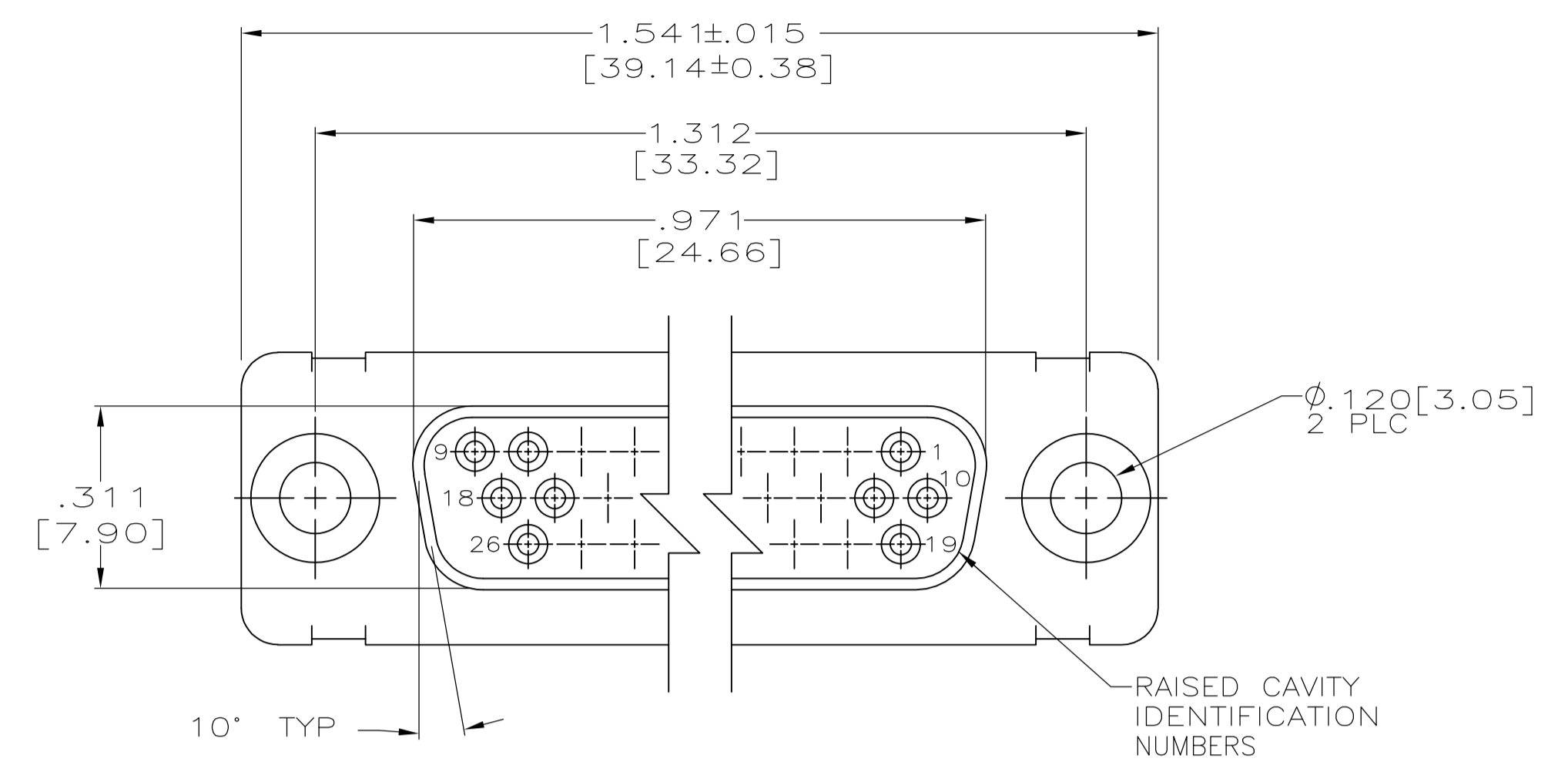
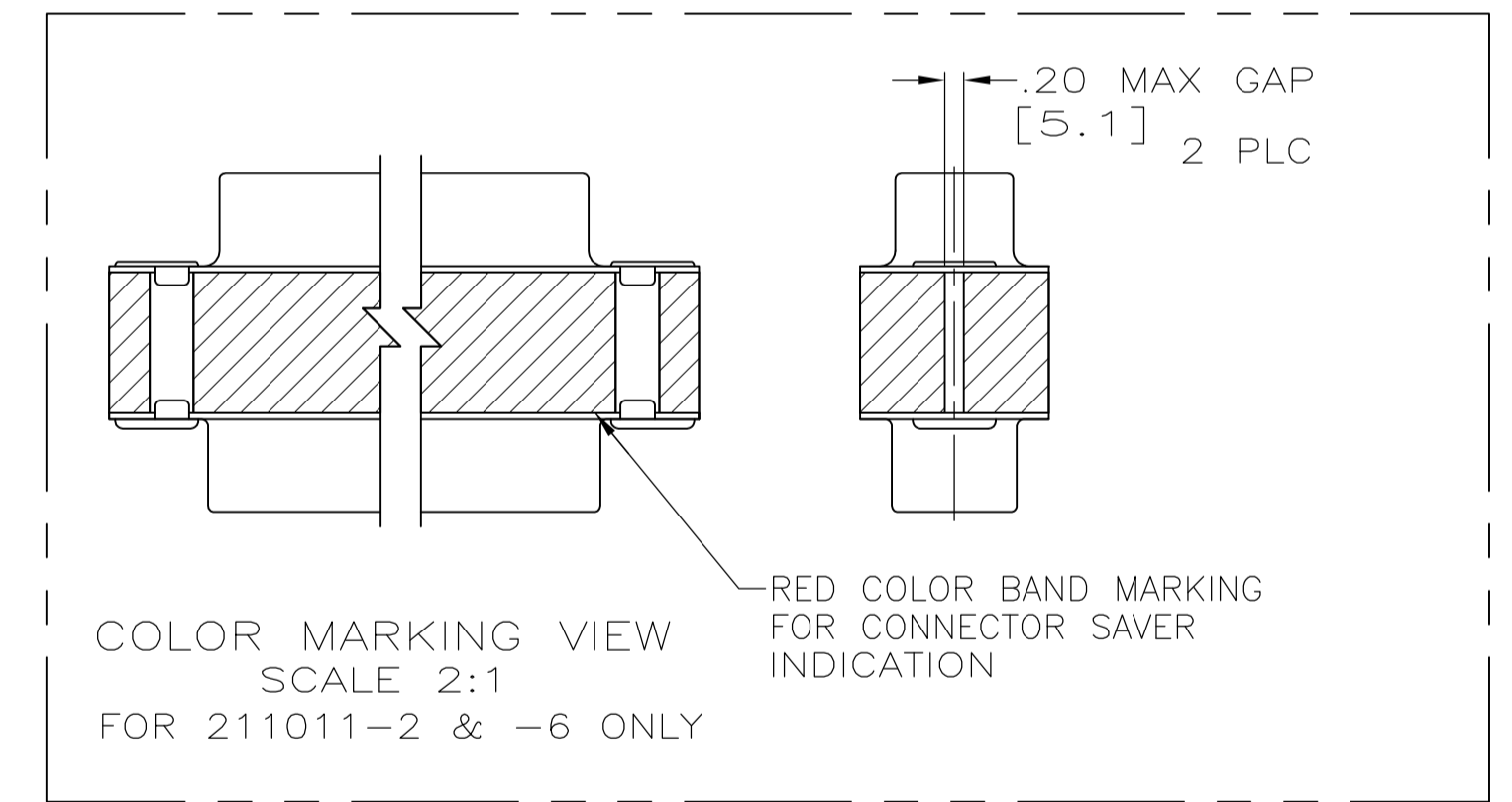

OBSOLETE	4	8	4	6	4U884 SOCN R10002677-0107	211011-6
	4	8	4	6	2A091-002W-001	211011-5
	4	8	4	9	-	211011-4
	4	8	4	9	-	211011-3
	4	8	4	6	(1J02-107)	211011-2
	4	8	4	6	-	211011-1
EYELET	SHELLS	CONTACT		CUSTOMER P/N	PART NO.	

THIS DRAWING IS A CONTROLLED DOCUMENT.		DMN C.C.THOMAS 11-3-98	TE Connectivity	
DIMENSIONS: INCHES		CHK J.NORTON 11-17-98		
TOLERANCES UNLESS OTHERWISE SPECIFIED:		APVD J.NORTON 11-17-98	NAME CONNECTOR SAVER,AMPLIMITE	
0 PLC ± -	1 PLC ± -	PRODUCT SPEC	26 POSN.,SIZE 2,SERIES 90	
2 PLC ± -	3 PLC ± .005 [0.13]	APPLICATION SPEC	-	
4 PLC ± -	ANGLES ± -	SIZE	CAGE CODE	DRAWING NO
MATERIAL	FINISH	WEIGHT	A1	00779
CUSTOMER DRAWING		SCALE	4:1	SHEET 1 OF 1
		REV	V	