

\* = Mass durch Formkonizität nach unten verringert.  
Freimass = Toleranz nach GTA 14/S = DIN 1688

(Backe)

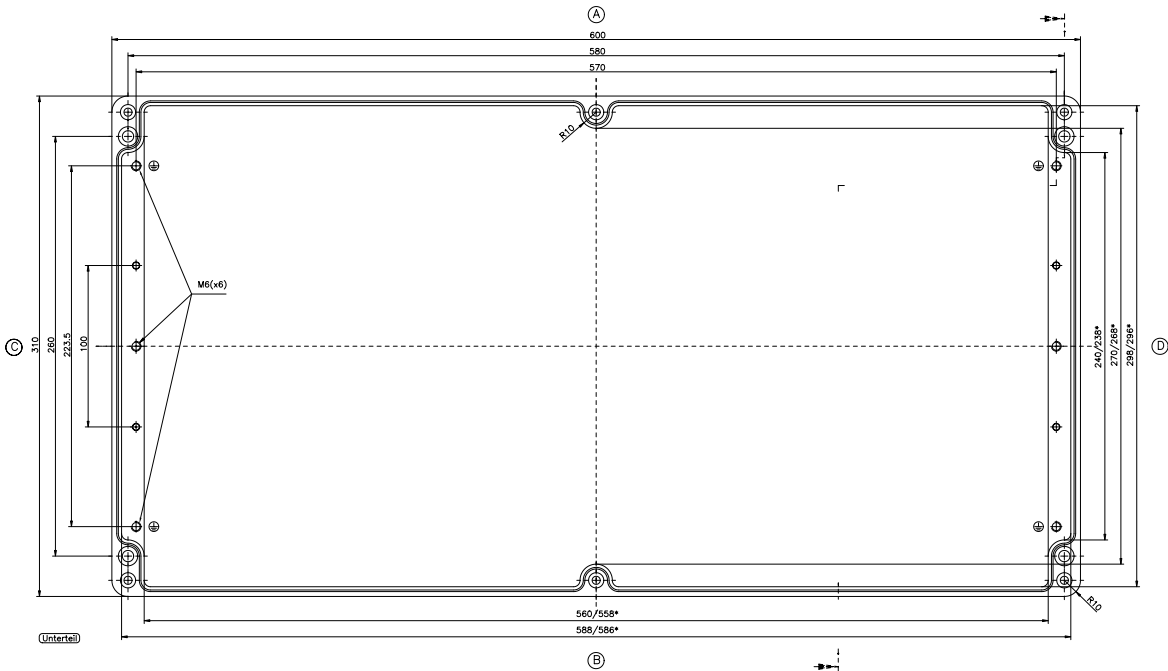

(Unterteil)

