

Emitter common (dual digital transistors)

EMA8 / UMA8N / FMA8A

●Features

1) Two DTA114Y chips in a EMT or UMT or SMT package.

●Equivalent circuit

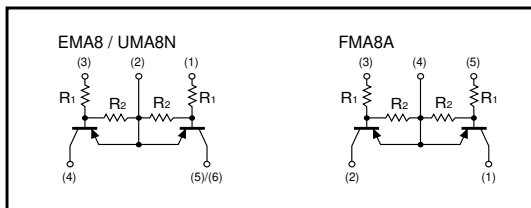

●Package, marking, and packaging specifications

Type	EMA8	UMA8N	FMA8A
Package	EMT5	UMT5	SMT5
Marking	A8	A8	A8
Code	T2R	TR	T148
Basic ordering unit (pieces)	8000	3000	3000

●Absolute maximum ratings (Ta = 25°C)

Parameter	Symbol	Limits	Unit
Supply voltage	V _{CC}	-50	V
Input voltage	V _{IN}	-40	V
		6	
Output current	I _O	-100	mA
Power dissipation	P _d	300(TOTAL)	mW *
Storage temperature	T _{stg}	-50~+150	°C

*200mW per element must not be exceeded.

●External dimensions (Units : mm)

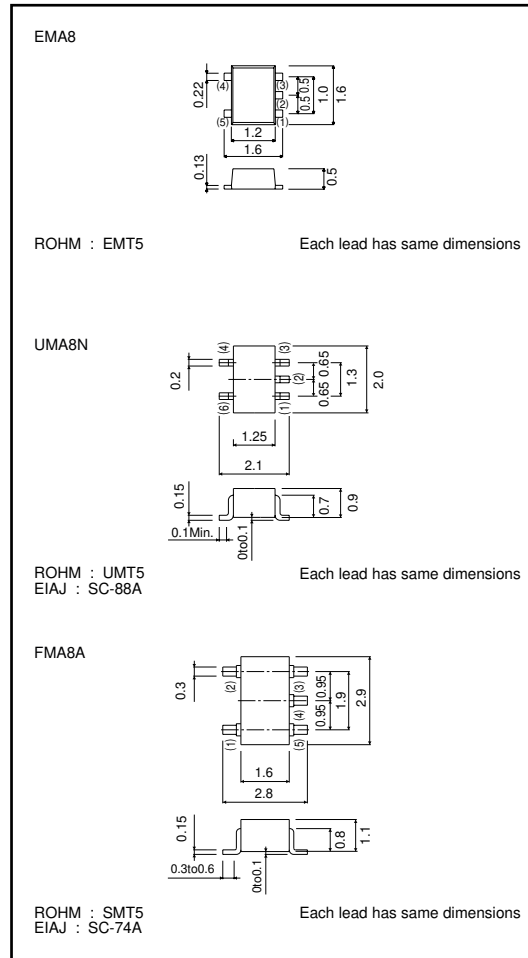

●Electrical characteristics (Ta = 25°C)

Parameter	Symbol	Min.	Typ.	Max.	Unit	Conditions
Input voltage	V _{I (off)}	-	-	-0.3	V	V _{CC} =-5V, I _O =-100μA
	V _{I (on)}	-1.4	-	-		V _O =-0.3V, I _O =-1mA
Output voltage	V _{O (on)}	-	-0.1	-0.3	V	I _O =-10mA, I _I =-0.5mA
Input current	I _I	-	-	-0.88	mA	V _I =-5V
Output current	I _{O (off)}	-	-	-0.5	μA	V _{CC} =-50V, V _I =0V
DC current gain	G _I	68	-	-	-	I _O =-5mA, V _O =-5V
Input resistance	R _I	-	10	-	kΩ	-
Resistance ratio	R ₂ /R ₁	3.7	4.7	5.7	-	-