



MRF49XA PICtail™/PICtail Plus Daughter Board User's Guide

Note the following details of the code protection feature on Microchip devices:

- Microchip products meet the specification contained in their particular Microchip Data Sheet.
- Microchip believes that its family of products is one of the most secure families of its kind on the market today, when used in the intended manner and under normal conditions.
- There are dishonest and possibly illegal methods used to breach the code protection feature. All of these methods, to our knowledge, require using the Microchip products in a manner outside the operating specifications contained in Microchip's Data Sheets. Most likely, the person doing so is engaged in theft of intellectual property.
- Microchip is willing to work with the customer who is concerned about the integrity of their code.
- Neither Microchip nor any other semiconductor manufacturer can guarantee the security of their code. Code protection does not mean that we are guaranteeing the product as "unbreakable."

Code protection is constantly evolving. We at Microchip are committed to continuously improving the code protection features of our products. Attempts to break Microchip's code protection feature may be a violation of the Digital Millennium Copyright Act. If such acts allow unauthorized access to your software or other copyrighted work, you may have a right to sue for relief under that Act.

Information contained in this publication regarding device applications and the like is provided only for your convenience and may be superseded by updates. It is your responsibility to ensure that your application meets with your specifications. MICROCHIP MAKES NO REPRESENTATIONS OR WARRANTIES OF ANY KIND WHETHER EXPRESS OR IMPLIED, WRITTEN OR ORAL, STATUTORY OR OTHERWISE, RELATED TO THE INFORMATION, INCLUDING BUT NOT LIMITED TO ITS CONDITION, QUALITY, PERFORMANCE, MERCHANTABILITY OR FITNESS FOR PURPOSE. Microchip disclaims all liability arising from this information and its use. Use of Microchip devices in life support and/or safety applications is entirely at the buyer's risk, and the buyer agrees to defend, indemnify and hold harmless Microchip from any and all damages, claims, suits, or expenses resulting from such use. No licenses are conveyed, implicitly or otherwise, under any Microchip intellectual property rights.

Trademarks

The Microchip name and logo, the Microchip logo, dsPIC, KEELOQ, KEELOQ logo, MPLAB, PIC, PICmicro, PICSTART, rfPIC and UNI/O are registered trademarks of Microchip Technology Incorporated in the U.S.A. and other countries.

FilterLab, Hampshire, HI-TECH C, Linear Active Thermistor, MXDEV, MXLAB, SEEVAL and The Embedded Control Solutions Company are registered trademarks of Microchip Technology Incorporated in the U.S.A.

Analog-for-the-Digital Age, Application Maestro, CodeGuard, dsPICDEM, dsPICDEM.net, dsPICworks, dsSPEAK, ECAN, ECONOMONITOR, FanSense, HI-TIDE, In-Circuit Serial Programming, ICSP, ICEPIC, Mindi, MiWi, MPASM, MPLAB Certified logo, MPLIB, MPLINK, mTouch, nanoWatt XLP, Omniscient Code Generation, PICC, PICC-18, PICKit, PICDEM, PICDEM.net, PICtail, PIC³² logo, REAL ICE, rfLAB, Select Mode, Total Endurance, TSHARC, WiperLock and ZENA are trademarks of Microchip Technology Incorporated in the U.S.A. and other countries.

SQTP is a service mark of Microchip Technology Incorporated in the U.S.A.

All other trademarks mentioned herein are property of their respective companies.

© 2009, Microchip Technology Incorporated, Printed in the U.S.A., All Rights Reserved.

 Printed on recycled paper.

QUALITY MANAGEMENT SYSTEM
CERTIFIED BY DNV
== ISO/TS 16949:2002 ==

Microchip received ISO/TS-16949:2002 certification for its worldwide headquarters, design and wafer fabrication facilities in Chandler and Tempe, Arizona; Gresham, Oregon and design centers in California and India. The Company's quality system processes and procedures are for its PIC® MCUs and dsPIC® DSCs, KEELOQ® code hopping devices, Serial EEPROMs, microperipherals, nonvolatile memory and analog products. In addition, Microchip's quality system for the design and manufacture of development systems is ISO 9001:2000 certified.



MRF49XA PICtail™/PICtail PLUS DAUGHTER BOARD USER'S GUIDE

Table of Contents

Preface	1
Introduction.....	1
Document Layout	1
Conventions Used in this Guide	2
Warranty Registration.....	3
Recommended Reading.....	3
The Microchip Web Site	4
Development Systems Customer Change Notification Service	4
Customer Support	5
Document Revision History	5
Chapter 1. Overview	
1.1 Introduction	7
1.2 MRF49XA PICtail/PICtail Plus Board Contents	7
1.3 MRF49XA PICtail/PICtail Plus Board	7
Chapter 2. Getting Started	
2.1 Introduction	9
2.2 Plugging into the PIC18 Explorer Board	9
2.3 Plugging into the Explorer 16 Development Board	10
Appendix A. MRF49XA PICtail/PICtail Plus Daughter Board Schematic	
A.1 Introduction	11
A.2 MRF49XA PICtail/PICtail Plus Daughter Board Schematic	12
A.3 MRF49XA PICtail/PICtail Plus Daughter Board PCB Layout	14
A.4 MRF49XA PICtail™/PICtail Plus Daughter Board Bill of Materials	16
Worldwide Sales and Service	18

MRF49XA PICtail™PICtail Plus Daughter Board User's Guide

NOTES:



MRF49XA PICtail™/PICtail PLUS DAUGHTER BOARD USER'S GUIDE

Preface

NOTICE TO CUSTOMERS

All documentation becomes dated, and this manual is no exception. Microchip tools and documentation are constantly evolving to meet customer needs, so some actual dialogs and/or tool descriptions may differ from those in this document. Please refer to our web site (www.microchip.com) to obtain the latest documentation available.

Documents are identified with a “DS” number. This number is located on the bottom of each page, in front of the page number. The numbering convention for the DS number is “DSXXXXA”, where “XXXX” is the document number and “A” is the revision level of the document.

For the most up-to-date information on development tools, see the MPLAB® IDE on-line help. Select the Help menu, and then Topics to open a list of available on-line help files.

INTRODUCTION

This chapter contains general information that will be useful to know before using the MRF49XA PICtail/PICtail Plus Daughter Board. Items discussed in this chapter include:

- Document Layout
- Conventions Used in this Guide
- Warranty Registration
- Recommended Reading
- The Microchip Web Site
- Development Systems Customer Change Notification Service
- Customer Support
- Document Revision History

DOCUMENT LAYOUT

This document describes how to use the MRF49XA PICtail™/PICtail Plus Daughter Board. The manual layout is as follows:

- **Chapter 1. “Overview”** This chapter provides an overview of the MRF49XA PICtail/PICtail Plus Daughter Board, including board contents and features.
- **Chapter 2. “Getting Started”** This chapter describes how to start using your MRF49XA PICtail/PICtail Plus Daughter Board
- **Appendix A. “MRF49XA PICtail/PICtail Plus Daughter Board Schematic”** This appendix contains the schematics, PCB information and Bill of Materials for the MRF49XA PICtail/PICtail Plus Daughter Board.

MRF49XA PICTail™/PICTail Plus Daughter Board User's Guide

CONVENTIONS USED IN THIS GUIDE

This manual uses the following documentation conventions:

DOCUMENTATION CONVENTIONS

Description	Represents	Examples
Arial font:		
Italic characters	Referenced books	<i>MPLAB® IDE User's Guide</i>
	Emphasized text	...is the <i>only</i> compiler...
Initial caps	A window	the Output window
	A dialog	the Settings dialog
	A menu selection	select Enable Programmer
Quotes	A field name in a window or dialog	"Save project before build"
Underlined, italic text with right angle bracket	A menu path	<u><i>File>Save</i></u>
Bold characters	A dialog button	Click OK
	A tab	Click the Power tab
N'Rnnnn	A number in verilog format, where N is the total number of digits, R is the radix and n is a digit.	4'b0010, 2'hF1
Text in angle brackets < >	A key on the keyboard	Press <Enter>, <F1>
Courier New font:		
Plain Courier New	Sample source code	#define START
	Filenames	autoexec.bat
	File paths	c:\mcc18\h
	Keywords	_asm, _endasm, static
	Command-line options	-Opa+, -Opa-
	Bit values	0, 1
	Constants	0xFF, 'A'
Italic Courier New	A variable argument	<i>file.o</i> , where <i>file</i> can be any valid filename
Square brackets []	Optional arguments	mcc18 [options] <i>file</i> [options]
Curly brackets and pipe character: { }	Choice of mutually exclusive arguments; an OR selection	errorlevel {0 1}
Ellipses...	Replaces repeated text	var_name [, var_name...]
	Represents code supplied by user	void main (void) { ... }

WARRANTY REGISTRATION

Please complete the enclosed Warranty Registration Card and mail it promptly. Sending in the Warranty Registration Card entitles users to receive new product updates. Interim software releases are available at the Microchip web site.

RECOMMENDED READING

This user's guide describes how to use the MRF49XA PICtail/PICtail Plus Daughter Board. Other useful documents are listed below. The following Microchip documents are available and recommended as supplemental reference resources.

MRF49XA ISM Band Sub-GHz RF Transceiver Data Sheet (DS70590)

PICDEM PIC18 Explorer Demonstration Board User's Guide (DS51721)

Explorer 16 Development Board User's Guide (DS51589)

2K SPI Bus Serial EEPROM with EUI-48™ Node Identity Data Sheet (DS22123)

MRF49XA PICtail™/PICtail Plus Daughter Board User's Guide

THE MICROCHIP WEB SITE

Microchip provides online support via our web site at www.microchip.com. This web site is used as a means to make files and information easily available to customers. Accessible by using your favorite Internet browser, the web site contains the following information:

- **Product Support** – Data sheets and errata, application notes and sample programs, design resources, user's guides and hardware support documents, latest software releases and archived software
- **General Technical Support** – Frequently Asked Questions (FAQs), technical support requests, online discussion groups, Microchip consultant program member listing
- **Business of Microchip** – Product selector and ordering guides, latest Microchip press releases, listing of seminars and events, listings of Microchip sales offices, distributors and factory representatives

DEVELOPMENT SYSTEMS CUSTOMER CHANGE NOTIFICATION SERVICE

Microchip's customer notification service helps keep customers current on Microchip products. Subscribers will receive e-mail notification whenever there are changes, updates, revisions or errata related to a specified product family or development tool of interest.

To register, access the Microchip web site at www.microchip.com, click on Customer Change Notification and follow the registration instructions.

The Development Systems product group categories are:

- **Compilers** – The latest information on Microchip C compilers and other language tools. These include the MPLAB C18 and MPLAB C30 C compilers; MPASM™ and MPLAB ASM30 assemblers; MPLINK™ and MPLAB LINK30 object linkers; and MPLIB™ and MPLAB LIB30 object librarians.
- **Emulators** – The latest information on Microchip in-circuit emulators. This includes the MPLAB ICE 2000 and MPLAB ICE 4000.
- **In-Circuit Debuggers** – The latest information on the Microchip in-circuit debugger, MPLAB ICD 2.
- **MPLAB® IDE** – The latest information on Microchip MPLAB IDE, the Windows® Integrated Development Environment for development systems tools. This list is focused on the MPLAB IDE, MPLAB SIM simulator, MPLAB IDE Project Manager and general editing and debugging features.
- **Programmers** – The latest information on Microchip programmers. These include the MPLAB PM3 and PRO MATE® II device programmers and the PICSTART® Plus and PICkit™ 1 development programmers.

CUSTOMER SUPPORT

Users of Microchip products can receive assistance through several channels:

- Distributor or Representative
- Local Sales Office
- Field Application Engineer (FAE)
- Technical Support

Customers should contact their distributor, representative or field application engineer (FAE) for support. Local sales offices are also available to help customers. A listing of sales offices and locations is included in the back of this document.

Technical support is available through the web site at: <http://support.microchip.com>

DOCUMENT REVISION HISTORY

Revision A (June 2009)

- Initial Release of this Document.

MRF49XA PICtail™/PICtail Plus Daughter Board User's Guide

NOTES:



MRF49XA PICtail™/PICtail PLUS DAUGHTER BOARD USER'S GUIDE

Chapter 1. Overview

1.1 INTRODUCTION

The MRF49XA PICtail™/PICtail Plus Daughter Board is a demonstration and development daughter board for the MRF49XA ISM Band Sub-GHz RF Transceiver. The daughter board can plug into multiple Microchip Technology demonstration and development boards. For example, for 8-bit microcontroller development using the PIC18 Explorer Board (DM183032) or for 16-bit microcontroller development using the Explorer 16 Development Board (DM240001).

A simple demonstration program has been written for the PIC18 Explorer Board. It may be downloaded from the Microchip website <http://www.microchip.com/wireless>.

This chapter discusses:

- MRF49XA PICtail/PICtail Plus Daughter Board Contents
- MRF49XA PICtail/PICtail Plus Daughter Board

1.2 MRF49XA PICtail/PICtail PLUS DAUGHTER BOARD CONTENTS

The MRF49XA PICtail/PICtail Plus Daughter Board contains the following items:

- Two MRF49XA PICtail/PICtail Plus Daughter Boards

The daughter boards come in two frequency versions. The individual part numbers are listed in Table 1-1.

TABLE 1-1: MRF49XA PICtail™/PICtail PLUS DAUGHTER BOARD

Description	Part Number
MRF49XA PICtail™/PICtail Plus Daughter Board (433.92 MHz)	AC164137-1
MRF49XA PICtail/PICtail Plus Daughter Board (868/915 MHz)	AC164137-2

1.3 MRF49XA PICtail/PICtail PLUS DAUGHTER BOARD

The MRF49XA PICtail/PICtail Plus Daughter Board is a complete sub-GHz wireless transceiver. The features are shown in Figure 1-1.

CAUTION

Power to the MRF49XA PICtail/PICtail Plus Daughter Board should be in the range of 2.2-3.8V. Ensure that the development/demonstration board that the daughter board is plugged into meets this voltage requirement; otherwise, damage to the MRF49XA may occur.

MRF49XA PICtail™/PICtail Plus Daughter Board User's Guide

FIGURE 1-1: MRF49XA PICtail™/PICtail PLUS DAUGHTER BOARD

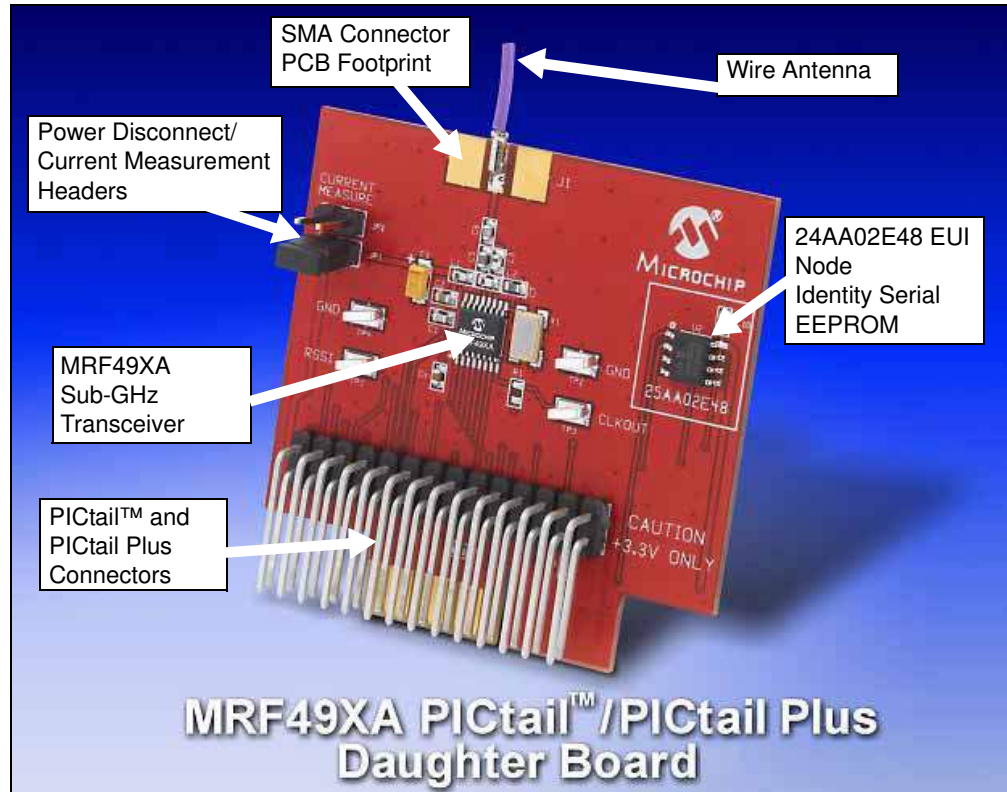

PICtail Connector (P1) – 28-pin right angle connector to connect to 8-bit development boards' PICtail connector.

PICtail Plus Connector (P2) – 30-pin card edge connector for connecting into 16 and 32-bit development boards' PICtail Plus connector.

MRF49XA (U1) – ISM sub-GHz Transceiver.

Power Disconnect/Current Measurement Headers (JP1/JP2) – Two, 2-pin headers are connected in parallel. A shunt connects power to the MRF49XA circuitry. A current meter can be placed on the header and the shunt removed to measure current consumption.

TIP: To prevent power interruption to the MRF49XA, keep the shunt on the header while connecting the current meter. Once connected, remove the shunt to measure current.

Note: Do not allow shunt resistance to exceed 50 ohms as it may lower the supply voltage to the MRF49XA and cause a glitch reset.

Antenna Connector (J1) – Populated with a receptacle pin to accept a wire antenna (24 AWG solid wire). For 433.92 MHz, the wire length is 6.8 inches. For 868/915 MHz, the wire length is 3.3 inches.

Note: The receptacle can be removed and a SMA or reverse polarity SMA connector can be soldered in place.

EUI Node Identity Serial EEPROM (U2) – Contains a unique IEEE EUI address. For more information, refer to the "2K SPI Bus Serial EEPROM with EUI-48™ Node Identity Data Sheet" (DS22123).

Chapter 2. Getting Started

2.1 INTRODUCTION

The MRF49XA PICtail/PICtail Plus Daughter Board can be plugged into multiple Microchip Technology demonstration and development boards. This allows the developer to choose the microcontroller that best suits the customer's development environment.

The PICtail connector right angle header, P1, can plug into 8-bit demonstration and development boards, such as the PIC18 Explorer Board (DM183032). The PICtail Plus card edge connector, P2, can plug into Explorer 16 Development Board (DM240001).

This chapter shows how the daughter board is plugged into the PIC18 Explorer and Explorer 16 Development Boards, and how to run the PIC18 Explorer Board demo programs.

2.2 PLUGGING INTO THE PIC18 EXPLORER BOARD

The MRF49XA PICtail/PICtail Plus Daughter Board can be plugged into the PIC18 Explorer Board PICtail connector, J3, as shown in Figure 2-1. Make sure to align pin 1 to RE2 as shown.

CAUTION

Ensure that the PIC18F87J11 PIM is plugged into the PIC18 Explorer Board. This sets the system VDD voltage to 3.3 volts, which is required by the MRF49XA PICtail/PICtail Plus Daughter Board.

FIGURE 2-1: MRF49XA PICtail™/PICtail PLUS DAUGHTER BOARD PLUGGED INTO PIC18 EXPLORER BOARD

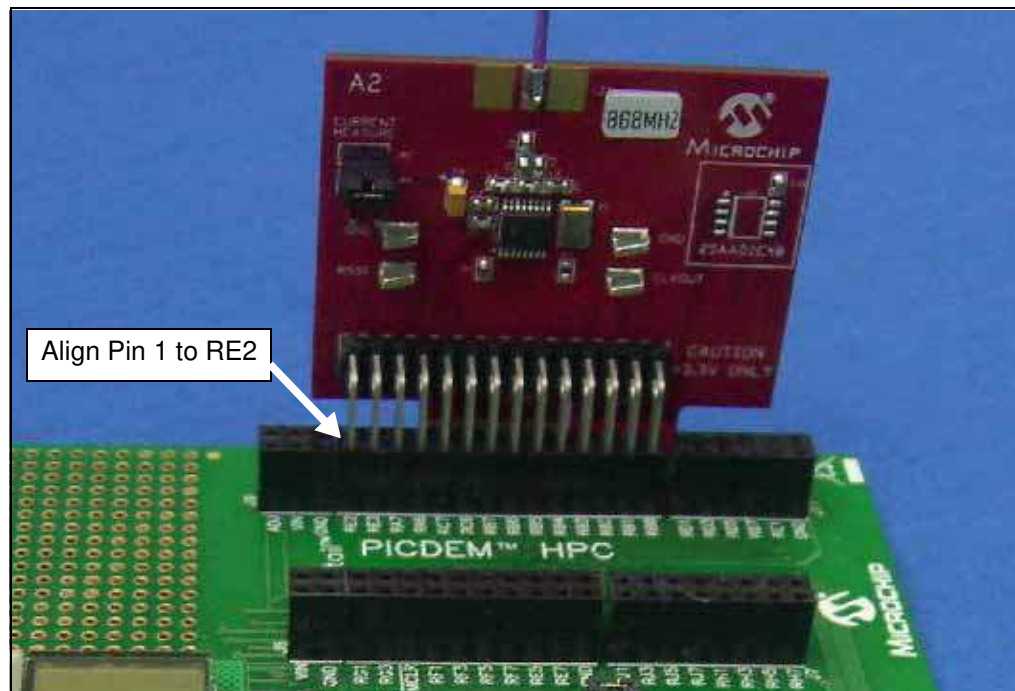

MRF49XA PICtail™/PICtail Plus Daughter Board User's Guide

2.2.1 Downloading and Running the Demo Program

A simple demonstration program has been written for the PIC18 Explorer Board. It may be downloaded from the Microchip website <http://www.microchip.com/wireless>. A Quick Start Guide is included in the software installation package that explains the installation and operation of the demo program.

2.3 PLUGGING INTO THE EXPLORER 16 DEVELOPMENT BOARD

The MRF49XA PICtail/PICtail Plus Daughter Board can be plugged into the Explorer 16 Development Board as shown in Figure 2-2.

The Daughter Board 30-pin card edge connector can be plugged into the top section of the PICtail Plus connector. This will connect to the SPI Port 1 on the PIC® microcontroller plugged into the PIM socket. If the Daughter Board is plugged into the mid-section of the PICtail Plus connector, this will connect to SPI Port 2 on the PIC microcontroller.

FIGURE 2-2: MRF49XA PICtail™/PICtail PLUS DAUGHTER BOARD PLUGGED INTO EXPLORER 16 DEVELOPMENT BOARD

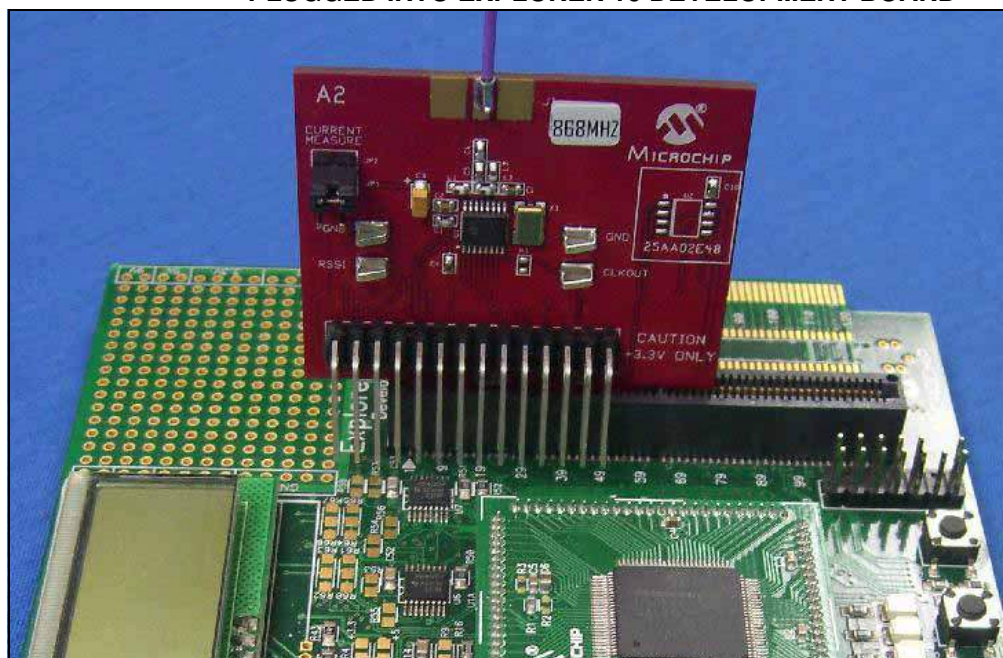



MRF49XA PICtail™/PICtail PLUS DAUGHTER BOARD USER'S GUIDE

Appendix A. MRF49XA PICtail/PICtail Plus Daughter Board Schematic

A.1 INTRODUCTION

This appendix provides the MRF49XA PICtail/PICtail Plus Daughter Board schematics, PCB layout and Bill of Materials (BOM).

- MRF49XA PICtail/PICtail Plus Daughter Board Schematic
- MRF49XA PICtail/PICtail Plus Daughter Board PCB Layout
- MRF49XA PICtail/PICtail Plus Daughter Board Bill of Materials

A.2 MRF49XA PICtail/PICtail Plus Daughter Board Schematic

FIGURE A-1: MRF49XA PICtail™/PICtail Plus Daughter Board Schematic (SHEET 1 OF 2)

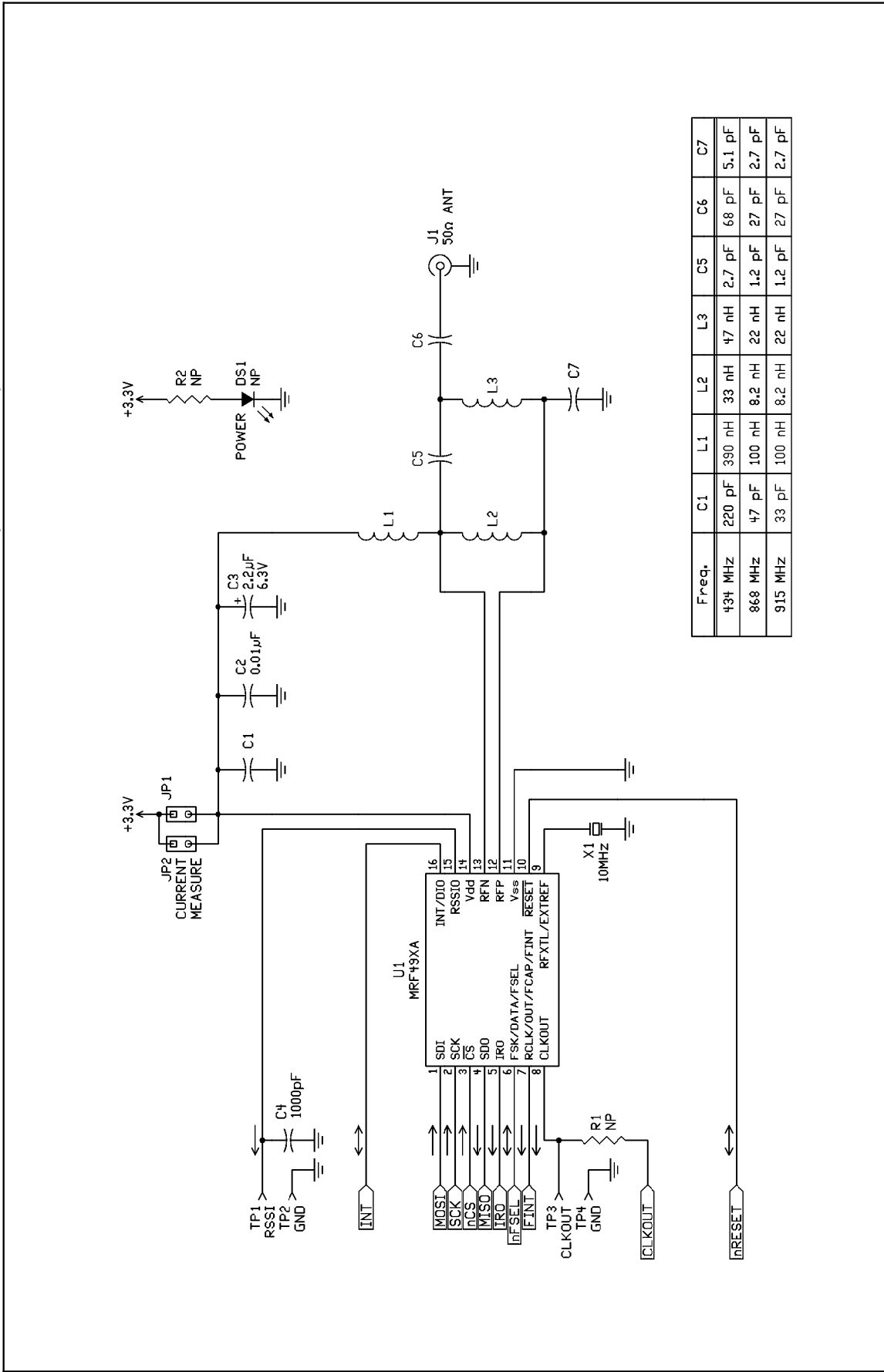

Freq.	C1	L1	L2	L3	C5	C6	C7
434 MHz	220 pF	390 nH	33 nH	47 nH	2.7 pF	68 pF	5.1 pF
868 MHz	47 pF	100 nH	8.2 nH	22 nH	1.2 pF	27 pF	2.7 pF
915 MHz	33 pF	100 nH	8.2 nH	22 nH	1.2 pF	27 pF	2.7 pF

MRF49XA PICtail/PICtail Plus Daughter Board Schematic

FIGURE A-2: A-2:MRF49XA PICtail™/PICtail Plus DAUGHTER BOARD SCHEMATIC (SHEET 2 OF 2)

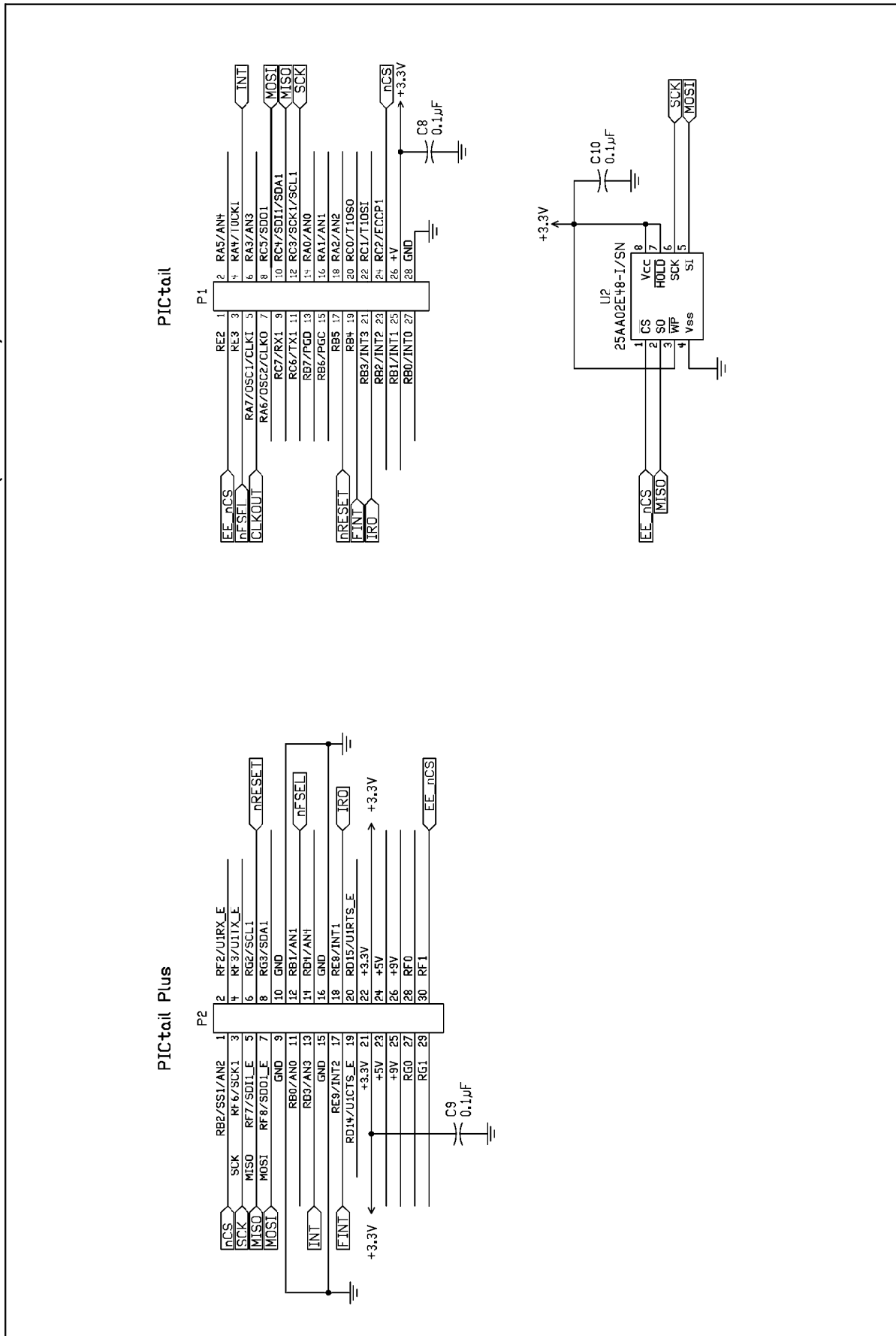

MRF49XA PICtail™/PICtail Plus Daughter Board User's Guide

A.3 MRF49XA PICtail/PICtail PLUS DAUGHTER BOARD PCB LAYOUT

The MRF49XA PICtail/PICtail Plus Daughter Board is a 2-layer, FR4, 0.062 inch, plated through hole PCB construction.

FIGURE A-3: MRF49XA PICtail™/PICtail PLUS DAUGHTER BOARD SILKSCREEN

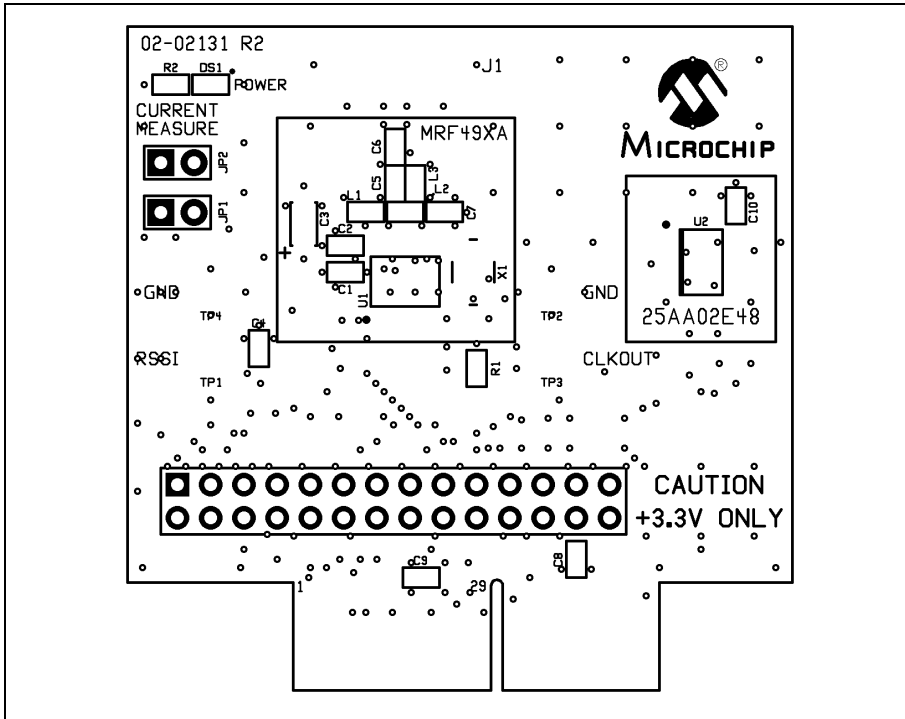
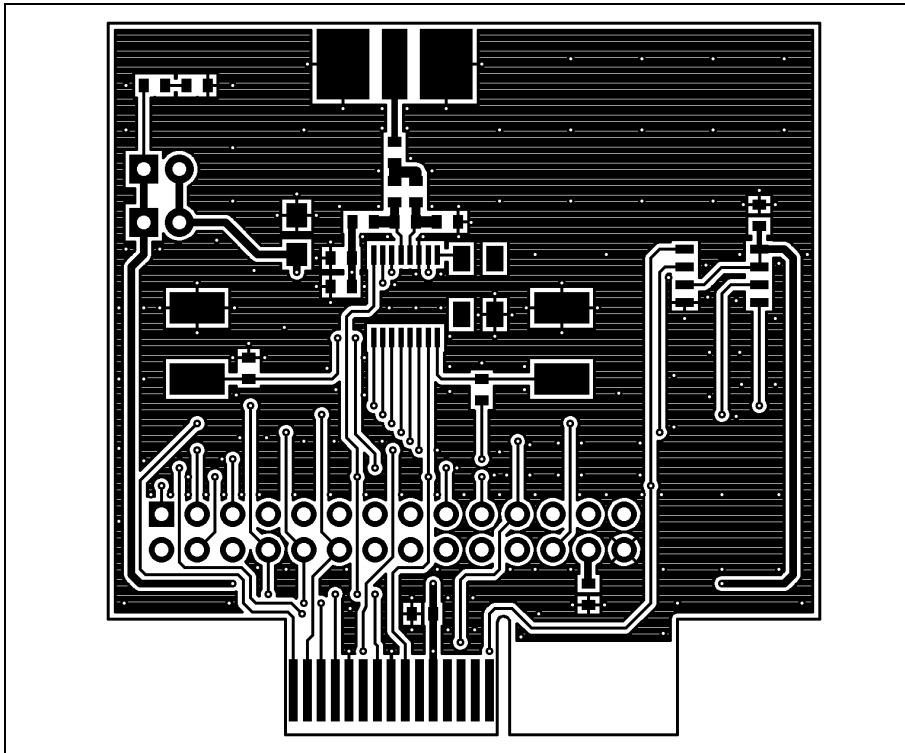

FIGURE A-4: MRF49XA PICtail™/PICtail PLUS DAUGHTER BOARD TOP COPPER



MRF49XA PICtail™/PICtail Plus Daughter Board User's Guide

A.4 MRF49XA PICtail™/PICtail PLUS DAUGHTER BOARD BILL OF MATERIALS

TABLE A-1: MRF49XA PICtail™/PICtail PLUS DAUGHTER BOARD BILL OF MATERIALS

Reference	Value	Description	Vendor	Vendor P/N	Comments
C1 (433.92 MHz)	200 pF	Capacitor, Ceramic, 50V, C0G, SMT 0603	Murata	GRM1885C1H201JA01D	Bypass capacitor dependant on transmit frequency
C1 (868/915 MHz)	33 pF	Capacitor, Ceramic, 50V, C0G, SMT 0603	Murata	GRM1885C1H330JA01D	Bypass capacitor dependant on transmit frequency
C2	10000 pF	Capacitor, Ceramic, 50V, 10%, SMT 0603, X7R	Murata	GRM188R71H103KA01D	Bypass capacitor
C3	2.2 uF	Capacitor, Tantalum, 10%, SMT 3216-18 (A)	Kemet	T491A225K010AT	Filter and bulk supply capacitor
C4	1000 pF	Capacitor, Ceramic, 50V, 10%, SMT 0603, X7R	Murata	GRM188R71H102KA01D	Bypass capacitor for analog RSSI signal
C5 (433 MHz)	2.7 pF	Capacitor, Ceramic, 50V, C0G, SMT 0603	Murata	GRM1885C1H2R7CZ01D	High frequency capacitor
C5 (868/915 MHz)			Murata	GRM1885C1H1R2CZ01D	High frequency capacitor, balun circuit
C6 (433 MHz)		Capacitor, Ceramic, 50V, C0G, SMT 0603	Murata	GRM1885C1H680JA01D	High frequency capacitor, balun circuit
C6 (868/915 MHz)			Murata	GRM1885C1H270JA01D	High frequency capacitor, balun circuit
C7 (433 MHz)		Capacitor, Ceramic, 50V, C0G, SMT 0603	Murata	GRM1885C1H5R1DZ01D	High frequency capacitor, balun circuit
C7 (868/915 MHz)			Murata	GRM1885C1H2R7CZ01D	High frequency capacitor, balun circuit
C8, C9, C10	0.1 uF	Capacitor, Ceramic, SMT 0603, X7R	Murata	GRM188R71C104KA01D	Bypass capacitor
L1 (433.92 MHz)	390 nH	Inductor, Ceramic, 5%, SMT 0603	Murata	LQW18ANR39J00D	Balun circuit
L1 (868/915 MHz)	100 nH	Inductor, Ceramic, 5%, SMT 0603	TDK Corporation	MLG1608BR10J	Balun circuit
L2 (433.92 MHz)	33 nH	Inductor, Ceramic, 5%, SMT 0603	TDK Corporation	MLG1608B33NJ	Balun circuit
L2 (868/915 MHz)	8.2 nH	Inductor, Ceramic, 5%, SMT 0603	TDK Corporation	MLG1608B8N2D	Balun circuit
L3 (433.92 MHz)	47 nH	Inductor, Ceramic, 5%, SMT 0603	TDK Corporation	MLG1608B47NJ	Balun circuit
L3 (868/915 MHz)	22 nH	Inductor, Ceramic, 5%, SMT 0603	TDK Corporation	MLG1608B22NJ	Balun circuit
R1	Not Populated				Jumper if CLKOUT feature to PIC microcontroller is desired
R2	Not Populated				Current limit series resistor for DS1
DS1	Not Populated				Power indication
U1	MRF49XA	ISM Sub-GHz Transceiver	Microchip Technology		
U2	25AA02E48	EUI-48 Node Identity Serial EEPROM	Microchip Technology		
X1	10 MHz	Crystal, +/-10 ppm, 12 pF, ESR 80 ohms, SMT 5x3.2mm	Abracon	ABM3B-10.000MHZ-12-R80-B-1-U-T	

MRF49XA PICtail/PICtail Plus Daughter Board Schematic

NOTES:



WORLDWIDE SALES AND SERVICE

AMERICAS

Corporate Office

2355 West Chandler Blvd.
Chandler, AZ 85224-6199
Tel: 480-792-7200
Fax: 480-792-7277
Technical Support:
<http://support.microchip.com>
Web Address:
www.microchip.com

Atlanta

Duluth, GA
Tel: 678-957-9614
Fax: 678-957-1455

Boston

Westborough, MA
Tel: 774-760-0087
Fax: 774-760-0088

Chicago

Itasca, IL
Tel: 630-285-0071
Fax: 630-285-0075

Cleveland

Independence, OH
Tel: 216-447-0464
Fax: 216-447-0643

Dallas

Addison, TX
Tel: 972-818-7423
Fax: 972-818-2924

Detroit

Farmington Hills, MI
Tel: 248-538-2250
Fax: 248-538-2260

Kokomo

Kokomo, IN
Tel: 765-864-8360
Fax: 765-864-8387

Los Angeles

Mission Viejo, CA
Tel: 949-462-9523
Fax: 949-462-9608

Santa Clara

Santa Clara, CA
Tel: 408-961-6444
Fax: 408-961-6445

Toronto

Mississauga, Ontario,
Canada
Tel: 905-673-0699
Fax: 905-673-6509

ASIA/PACIFIC

Asia Pacific Office

Suites 3707-14, 37th Floor
Tower 6, The Gateway
Harbour City, Kowloon
Hong Kong
Tel: 852-2401-1200
Fax: 852-2401-3431

Australia - Sydney

Tel: 61-2-9868-6733
Fax: 61-2-9868-6755

China - Beijing

Tel: 86-10-8528-2100
Fax: 86-10-8528-2104

China - Chengdu

Tel: 86-28-8665-5511
Fax: 86-28-8665-7889

China - Hong Kong SAR

Tel: 852-2401-1200
Fax: 852-2401-3431

China - Nanjing

Tel: 86-25-8473-2460
Fax: 86-25-8473-2470

China - Qingdao

Tel: 86-532-8502-7355
Fax: 86-532-8502-7205

China - Shanghai

Tel: 86-21-5407-5533
Fax: 86-21-5407-5066

China - Shenyang

Tel: 86-24-2334-2829
Fax: 86-24-2334-2393

China - Shenzhen

Tel: 86-755-8203-2660
Fax: 86-755-8203-1760

China - Wuhan

Tel: 86-27-5980-5300
Fax: 86-27-5980-5118

China - Xiamen

Tel: 86-592-2388138
Fax: 86-592-2388130

China - Xian

Tel: 86-29-8833-7252
Fax: 86-29-8833-7256

China - Zhuhai

Tel: 86-756-3210040
Fax: 86-756-3210049

ASIA/PACIFIC

India - Bangalore

Tel: 91-80-3090-4444
Fax: 91-80-3090-4080

India - New Delhi

Tel: 91-11-4160-8631
Fax: 91-11-4160-8632

India - Pune

Tel: 91-20-2566-1512
Fax: 91-20-2566-1513

Japan - Yokohama

Tel: 81-45-471- 6166
Fax: 81-45-471-6122

Korea - Daegu

Tel: 82-53-744-4301
Fax: 82-53-744-4302

Korea - Seoul

Tel: 82-2-554-7200
Fax: 82-2-558-5932 or
82-2-558-5934

Malaysia - Kuala Lumpur

Tel: 60-3-6201-9857
Fax: 60-3-6201-9859

Malaysia - Penang

Tel: 60-4-227-8870
Fax: 60-4-227-4068

Philippines - Manila

Tel: 63-2-634-9065
Fax: 63-2-634-9069

Singapore

Tel: 65-6334-8870
Fax: 65-6334-8850

Taiwan - Hsin Chu

Tel: 886-3-6578-300
Fax: 886-3-6578-370

Taiwan - Kaohsiung

Tel: 886-7-536-4818
Fax: 886-7-536-4803

Taiwan - Taipei

Tel: 886-2-2500-6610
Fax: 886-2-2508-0102

Thailand - Bangkok

Tel: 66-2-694-1351
Fax: 66-2-694-1350

EUROPE

Austria - Wels

Tel: 43-7242-2244-39
Fax: 43-7242-2244-393

Denmark - Copenhagen

Tel: 45-4450-2828
Fax: 45-4485-2829

France - Paris

Tel: 33-1-69-53-63-20
Fax: 33-1-69-30-90-79

Germany - Munich

Tel: 49-89-627-144-0
Fax: 49-89-627-144-44

Italy - Milan

Tel: 39-0331-742611
Fax: 39-0331-466781

Netherlands - Drunen

Tel: 31-416-690399
Fax: 31-416-690340

Spain - Madrid

Tel: 34-91-708-08-90
Fax: 34-91-708-08-91

UK - Wokingham

Tel: 44-118-921-5869
Fax: 44-118-921-5820

03/26/09