

# 2.5/3.3 V, 200 MHz High-Speed Multi-Phase PLL Clock Buffer

## Features

- 2.5 V or 3.3 V operation
- Split output bank power supplies
- Output frequency range: 6 MHz to 200 MHz
- 50 ps typical matched-pair output-output skew
- 50 ps typical cycle-cycle jitter
- 49.5 / 50.5% typical output duty cycle
- Selectable output drive strength
- Selectable positive or negative edge synchronization
- Eight LVTTTL outputs driving 50Ω terminated lines
- LVCMOS / LVTTTL overvoltage tolerant reference input
- Phase adjustments in 625 / 1250 ps steps up to ±7.5 ns
- 2×, 4× multiply and (1/2)×, (1/4)× divide ratios
- Spread spectrum compatible
- Industrial temperature range: -40 °C to +85 °C
- 32-pin TQFP package

## Functional Description

The CY7B9950 RoboClock® is a low voltage, low power, eight-output, 200 MHz clock driver. It features output phase programmability which is necessary to optimize the clock tree design of high performance computer and communication systems.

The user can program the phase of the output banks through nF[0:1] pins. The adjustable phase feature enables the user to skew the outputs to lead or lag the reference clock. Any one of the outputs can be connected to the feedback input to achieve different reference frequency multiplications, divide ratios, and zero input-output delay.

The device also features split output bank power supplies, which enable the user to run two banks (1Qn and 2Qn) at a power supply level different from that of the other two banks (3Qn and 4Qn). Additionally, the three-level PE/HD pin controls the synchronization of the output signals to either the rising or falling edge of the reference clock and selects the drive strength of the output buffers. The high drive option (PE/HD = MID) increases the output current from ± 12 mA to ± 24 mA(3.3 V).

For a complete list of related documentation, [click here](#).

## Logic Block Diagram

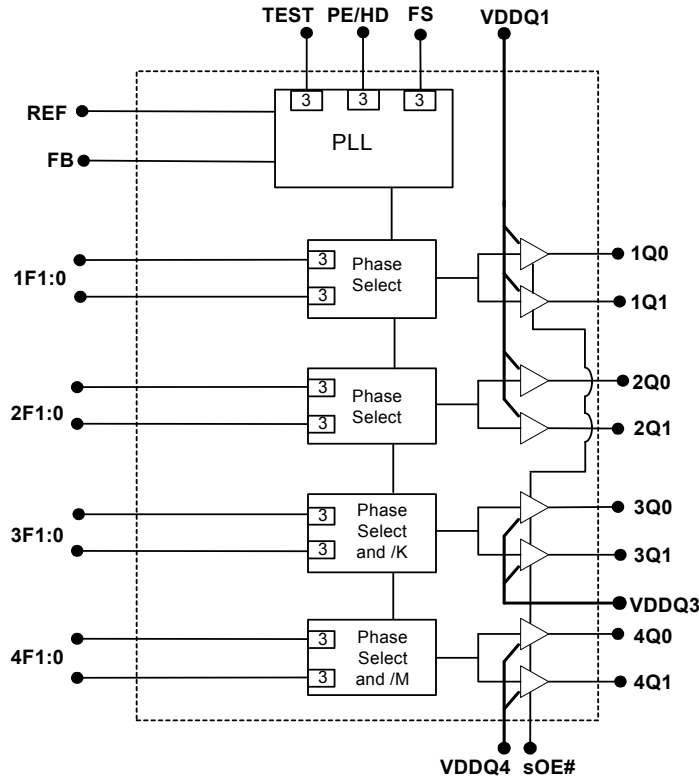

**Contents**

|  |           |  |           |
|--|-----------|--|-----------|
| <b>Pinouts</b> .....                               | <b>3</b>  | <b>Ordering Information</b> .....                    | <b>13</b> |
| <b>Pin Definitions</b> .....                       | <b>4</b>  | Ordering Code Definitions .....                      | 13        |
| <b>Device Configuration</b> .....                  | <b>5</b>  | <b>Package Diagram</b> .....                         | <b>14</b> |
| <b>Governing Agencies</b> .....                    | <b>5</b>  | <b>Acronyms</b> .....                                | <b>15</b> |
| <b>Absolute Maximum Conditions</b> .....           | <b>6</b>  | <b>Document Conventions</b> .....                    | <b>15</b> |
| <b>Operating Conditions</b> .....                  | <b>6</b>  | Units of Measure .....                               | 15        |
| <b>DC Electrical Specifications at 2.5 V</b> ..... | <b>7</b>  | <b>Document History Page</b> .....                   | <b>16</b> |
| <b>DC Electrical Specifications at 3.3 V</b> ..... | <b>8</b>  | <b>Sales, Solutions, and Legal Information</b> ..... | <b>18</b> |
| <b>Thermal Resistance</b> .....                    | <b>9</b>  | Worldwide Sales and Design Support .....             | 18        |
| <b>AC Test Loads and Waveforms</b> .....           | <b>9</b>  | Products .....                                       | 18        |
| <b>AC Input Specifications</b> .....               | <b>10</b> | PSoC@Solutions .....                                 | 18        |
| <b>Switching Characteristics</b> .....             | <b>11</b> | Cypress Developer Community .....                    | 18        |
| <b>AC Timing Definitions</b> .....                 | <b>12</b> | Technical Support .....                              | 18        |

Pinouts

Figure 1. 32-pin TQFP pinout (Top View)

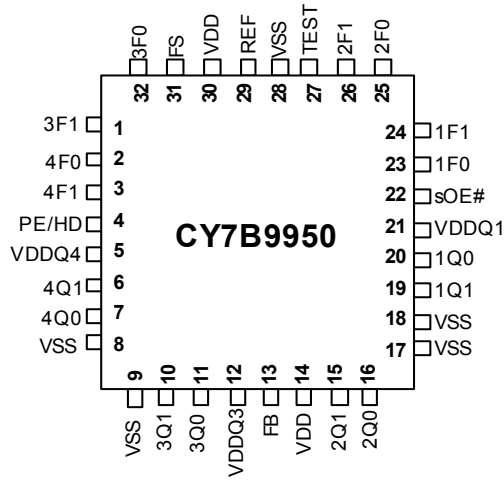

## Pin Definitions

| Pin                          | Name                             | I/O <sup>[1]</sup> | Type           | Description   |
|------------------------------|----------------------------------|--------------------|----------------|---|
| 29                           | REF                              | I                  | LVTTL / LVCMOS | Reference clock input.  |
| 13                           | FB                               | I                  | LVTTL          | Feedback input.   |
| 27                           | TEST                             | I                  | Three-level    | When MID or HIGH, disables PLL <sup>[2]</sup> . REF goes to outputs of Bank 1 and Bank 2. REF also goes to outputs of Bank 3 and Bank 4 through output dividers K and M. Set LOW for normal operation.  |
| 22                           | sOE#                             | I, PD              | Two-level      | Synchronous output enable. When HIGH, it stops clock outputs (except 2Q0 and 2Q1) in a Low state (for PE = H or M) – 2Q0, and 2Q1 may be used as the feedback signal to maintain phase lock. When test is held at MID level and sOE# is HIGH, the nF[1:0] pins act as output disable controls for individual banks when nF[1:0] = LL. Set sOE# Low for normal operation.        |
| 4                            | PE/HD                            | I, PU              | Three-level    | Selects Positive or negative edge control and High or low output drive strength. When Low/High the outputs are synchronized with the negative/positive edge of the reference clock, respectively. When at MID level, the output drive strength is increased and the outputs synchronize with the positive edge of the reference clock (see <a href="#">Table 6 on page 5</a> ). |
| 24, 23, 26, 25, 1, 32, 3, 2  | nF[1:0]                          | I                  | Three-level    | Select frequency and phase of the outputs (see <a href="#">Table 1</a> , <a href="#">Table 2</a> , <a href="#">Table 3 on page 5</a> , <a href="#">Table 4 on page 5</a> , and <a href="#">Table 5 on page 5</a> ).   |
| 31                           | FS                               | I                  | Three-level    | Selects VCO operating frequency range (see <a href="#">Table 4 on page 5</a> )  |
| 19, 20, 15, 16, 10, 11, 6, 7 | nQ[1:0]                          | O                  | LVTTL          | Four banks of two outputs (see <a href="#">Table 1</a> , <a href="#">Table 2</a> , and <a href="#">Table 3 on page 5</a> )  |
| 21                           | V <sub>DDQ1</sub> <sup>[3]</sup> | PWR                | Power          | Power supply for Bank 1 and Bank 2 output buffers (see <a href="#">Table 7 on page 5</a> for supply level constraints).   |
| 12                           | V <sub>DDQ3</sub> <sup>[3]</sup> | PWR                | Power          | Power supply for Bank 3 output buffers (see <a href="#">Table 7 on page 5</a> for supply level constraints).  |
| 5                            | V <sub>DDQ4</sub> <sup>[3]</sup> | PWR                | Power          | Power supply for Bank 4 output buffers (see <a href="#">Table 7 on page 5</a> for supply level constraints).  |
| 14, 30                       | V <sub>DD</sub> <sup>[3]</sup>   | PWR                | Power          | Power supply for internal circuitry (see <a href="#">Table 7 on page 5</a> for supply level constraints).   |
| 8, 9, 17, 18, 28             | V <sub>SS</sub>                  | PWR                | Power          | Ground  |

### Notes

1. PD indicates an internal pull-down and PU indicates an internal pull-up. 3 indicates a three-level input buffer.
2. When TEST = MID and sOE# = HIGH, PLL remains active with nF[1:0] = LL functioning as an output disable control for individual output banks. Skew selections remain in effect unless nF[1:0] = LL.
3. A bypass capacitor (0.1µF) must be placed as close as possible to each positive power pin (< 0.2"). If these bypass capacitors are not close to the pins their high-frequency filtering characteristic are cancelled by the lead inductance of the traces.

## Device Configuration

The outputs of the CY7B9950 can be configured to run at frequencies ranging from 6 to 200 MHz. Banks 3 and 4 output dividers are controlled by 3F[1:0] and 4F[1:0] as indicated in Table 1 and Table 2, respectively.

**Table 1. Output Divider Settings — Bank 3**

| 3F[1:0]              | K — Bank3 output divider |
|----------------------|--------------------------|
| LL                   | 2                        |
| HH                   | 4                        |
| Other <sup>[4]</sup> | 1                        |

**Table 2. Output Divider Settings — Bank 4**

| 4F[1:0]              | M — Bank4 output divider |
|----------------------|--------------------------|
| LL                   | 2                        |
| Other <sup>[4]</sup> | 1                        |

The three-level FS control pin setting determines the nominal operating frequency range of the divide-by-one outputs of the device. The CY7B9950 PLL operating frequency range that corresponds to each FS level is given in Table 3 on page 5.

**Table 3. Frequency Range Select**

| FS | PLL frequency range |
|----|---------------------|
| L  | 24 to 50 MHz        |
| M  | 48 to 100 MHz       |
| H  | 96 to 200 MHz       |

The selectable output skew is in discrete increments of time units ( $t_U$ ). The value of  $t_U$  is determined by the FS setting and the maximum nominal frequency. The equation used to determine the  $t_U$  value is:  $t_U = 1 / (f_{NOM} \times MF)$ , where MF is a multiplication factor, which is determined by the FS setting as indicated in Table 4.

**Table 4. MF Calculation**

| FS | MF | $f_{NOM}$ at which $t_U$ is 1.0 ns (MHz) |
|----|----|--|
| L  | 32 | 31.25                                    |
| M  | 16 | 62.5                                     |
| H  | 8  | 125                                      |

**Table 5. Output Skew Settings**

| nF[1:0]           | Skew (1Q[0:1],2Q[0:1]) | Skew (3Q[0:1]) | Skew (4Q[0:1]) |
|-------------------|------------------------|----------------|----------------|
| LL <sup>[5]</sup> | $-4t_U$                | Divide by 2    | Divide by 2    |
| LM                | $-3t_U$                | $-6t_U$        | $-6t_U$        |

**Notes**

- These states are used to program the phase of the respective banks (see Table 5 on page 5).
- LL disables outputs if TEST = MID and sOE# = HIGH.
- When 4Q[0:1] are set to run inverted (HH mode), sOE# disables these outputs HIGH when PE/HD = HIGH or MID and sOE# disables them LOW when PE/HD = LOW.
- Please refer to "DC Parameters" section for  $I_{QH}/I_{OL}$  specifications.
- $V_{DDQ1/3/4}$  must not be set at a level higher than that of  $V_{DD}$ . They can be set at different levels from each other, e.g.,  $V_{DD} = 3.3$  V,  $V_{DDQ1} = 3.3$  V,  $V_{DDQ3} = 2.5$  V and  $V_{DDQ4} = 2.5$  V.

**Table 5. Output Skew Settings(continued)**

| nF[1:0] | Skew (1Q[0:1],2Q[0:1]) | Skew (3Q[0:1]) | Skew (4Q[0:1])          |
|---------|------------------------|----------------|-------------------------|
| LH      | $-2t_U$                | $-4t_U$        | $-4t_U$                 |
| ML      | $-1t_U$                | $-2t_U$        | $-2t_U$                 |
| MM      | Zero skew              | Zero skew      | Zero skew               |
| MH      | $+1t_U$                | $+2t_U$        | $+2t_U$                 |
| HL      | $+2t_U$                | $+4t_U$        | $+4t_U$                 |
| HM      | $+3t_U$                | $+6t_U$        | $+6t_U$                 |
| HH      | $+4t_U$                | Divide by 4    | Inverted <sup>[6]</sup> |

In addition to determining whether the outputs synchronize to the rising or the falling edge of the reference signal, the 3-level PE/HD pin controls the output buffer drive strength as indicated in Table 6.

The CY7B9950 RoboClock® features split power supply buses for Banks 1 and 2, Bank 3 and Bank 4, which enables the user to obtain both 3.3 V and 2.5 V output signals from one device. The core power supply ( $V_{DD}$ ) must be set at a level that is equal to or higher than any one of the output power supplies.

**Table 6. PE/HD Settings**

| PE/HD | Synchronization | Output drive strength <sup>[7]</sup> |
|-------|-----------------|--------------------------------------|
| L     | Negative        | Low drive                            |
| M     | Positive        | High drive                           |
| H     | Positive        | Low drive                            |

**Table 7. Power Supply Constraints**

| $V_{DD}$ | $V_{DDQ1}$ <sup>[8]</sup> | $V_{DDQ3}$ <sup>[8]</sup> | $V_{DDQ4}$ <sup>[8]</sup> |
|----------|---------------------------|---------------------------|---------------------------|
| 3.3 V    | 3.3 V or 2.5 V            | 3.3 V or 2.5 V            | 3.3 V or 2.5 V            |
| 2.5 V    | 2.5 V                     | 2.5 V                     | 2.5 V                     |

## Governing Agencies

The following agencies provide specifications that apply to the CY7B9950 RoboClock®. The agency name and relevant specification is listed below.

**Table 8. Governing Agencies and Specifications**

| Agency name | Specification                              |
|-------------|--|
| JEDEC       | JESD 51 (theta JA), JESD 65 (skew, jitter) |
| IEEE        | 1596.3 (jitter specs)                      |
| UL-194_V0   | 94 (moisture grading)                      |
| MIL         | 883E method 1012.1 (therma theta JC)       |

## Absolute Maximum Conditions

| Parameter            | Description                       | Condition                   | Min                   | Max                   | Unit |
|----------------------|-----------------------------------|-----------------------------|-----------------------|-----------------------|------|
| V <sub>DD</sub>      | Supply voltage                    |                             | –                     | 4.6                   | V    |
| V <sub>IN(MIN)</sub> | Input voltage                     | Relative to V <sub>SS</sub> | V <sub>SS</sub> – 0.3 | –                     | V    |
| V <sub>IN(MAX)</sub> | Input voltage                     | Relative to V <sub>DD</sub> | –                     | V <sub>DD</sub> + 0.3 | V    |
| T <sub>S</sub>       | Temperature, storage              | Non-functional              | –65                   | 150                   | °C   |
| T <sub>J</sub>       | Temperature, junction             | Functional                  | –                     | 155                   | °C   |
| ∅ <sub>JC</sub>      | Dissipation, junction to case     | Mil-Spec 883E Method 1012.1 | –                     | 42                    | °C/W |
| ∅ <sub>JA</sub>      | Dissipation, junction to ambient  | JEDEC (JESD 51)             | –                     | 105                   | °C/W |
| ESD <sub>HBM</sub>   | ESD protection (human body model) | MIL-STD-883, Method 3015    | 2000                  | –                     | V    |
| UL-94                | Flammability rating               | At 1/8 in.                  | V–0                   |                       |      |
| MSL                  | Moisture sensitivity level        |                             | 3                     |                       |      |
| FIT                  | Failure in time                   | Manufacturing testing       | 10                    |                       | ppm  |

## Operating Conditions

| Parameter       | Description                    | Condition   | Min   | Max   | Unit |
|-----------------|--------------------------------|-------------|-------|-------|------|
| V <sub>DD</sub> | Operating voltage              | 2.5 V ± 5%  | 2.375 | 2.625 | V    |
|                 |                                | 3.3 V ± 10% | 2.97  | 3.63  | V    |
| T <sub>A</sub>  | Temperature, operating ambient |             | –40   | 85    | °C   |

**DC Electrical Specifications at 2.5 V**

| Parameter       | Description              | Condition   | Min   | Max              | Unit          |               |
|-----------------|--------------------------|---|---|------------------|---------------|---------------|
| $V_{IL}$        | Input low voltage        | REF, FB and sOE# Inputs   | –   | 0.7              | V             |               |
| $V_{IH}$        | Input high voltage       |   | 1.7   | –                | V             |               |
| $V_{IHH}^{[9]}$ | Input high voltage       | 3-level inputs<br>(TEST, FS, nF[1:0], PE/HD) (These pins are normally wired to $V_{DD}$ , GND, or unconnected.) | $V_{DD} - 0.4$                                  | –                | V             |               |
| $V_{IMM}^{[9]}$ | Input MID voltage        |   | $V_{DD}/2 - 0.2$                                | $V_{DD}/2 + 0.2$ | V             |               |
| $V_{ILL}^{[9]}$ | Input low voltage        |   | –   | 0.4              | V             |               |
| $I_{IL}$        | Input leakage current    | $V_{IN} = V_{DD}/GND$ ,<br>$V_{DD} = \text{max.}$ (REF and FB inputs)   | –5  | 5                | $\mu\text{A}$ |               |
| $I_3$           | 3-level input DC current | HIGH, $V_{IN} = V_{DD}$   | 3-level inputs<br>(TEST, FS, nF[1:0],<br>PE/HD) | –                | 200           | $\mu\text{A}$ |
|                 |                          | MID, $V_{IN} = V_{DD}/2$  |   | –50              | 50            | $\mu\text{A}$ |
|                 |                          | LOW, $V_{IN} = V_{SS}$  |   | –200             | –             | $\mu\text{A}$ |
| $I_{PU}$        | Input pull-up current    | $V_{IN} = V_{SS}$ , $V_{DD} = \text{max.}$  | –25   | –                | $\mu\text{A}$ |               |
| $I_{PD}$        | Input pull-down current  | $V_{IN} = V_{DD}$ , $V_{DD} = \text{max.}$ , (sOE#)   | –   | 100              | $\mu\text{A}$ |               |
| $V_{OL}$        | Output low voltage       | $I_{OL} = 12 \text{ mA}$ (PE/HD = L/H), (nQ[0:1])   | –   | 0.4              | V             |               |
|                 |                          | $I_{OL} = 20 \text{ mA}$ (PE/HD = MID), (nQ[0:1])   | –   | 0.4              | V             |               |
| $V_{OH}$        | Output high voltage      | $I_{OH} = -12 \text{ mA}$ (PE/HD = L/H), (nQ[0:1])  | 2.0   | –                | V             |               |
|                 |                          | $I_{OH} = -20 \text{ mA}$ (PE/HD = MID), (nQ[0:1])  | 2.0   | –                | V             |               |
| $I_{DDQ}$       | Quiescent supply current | $V_{DD} = \text{max.}$ , TEST = MID, REF = LOW,<br>sOE# = LOW, outputs not loaded                               | –   | 2                | mA            |               |
| $I_{DD}$        | Dynamic supply current   | At 100 MHz  | 150   |                  | mA            |               |
| $C_{IN}$        | Input pin capacitance    |   | 4   |                  | pF            |               |

**Note**

9. These inputs are normally wired to  $V_{DD}$ , GND or unconnected. Internal termination resistors bias unconnected inputs to  $V_{DD}/2$ .

**DC Electrical Specifications at 3.3 V**

| Parameter        | Description              | Condition  | Min   | Max              | Unit          |               |
|------------------|--------------------------|--|---|------------------|---------------|---------------|
| $V_{IL}$         | Input LOW voltage        | REF, FB and sOE# Inputs  | –   | 0.8              | V             |               |
| $V_{IH}$         | Input HIGH voltage       |  | 2.0   | –                | V             |               |
| $V_{IHH}^{[10]}$ | Input HIGH voltage       | 3-level inputs<br>(TEST, FS, nF[1:0], PE/HD) (These pins are normally wired to $V_{DD}$ , GND or unconnected.) | $V_{DD} - 0.6$  | –                | V             |               |
| $V_{IMM}^{[10]}$ | Input MID voltage        |  | $V_{DD}/2 - 0.3$  | $V_{DD}/2 + 0.3$ | V             |               |
| $V_{ILL}^{[10]}$ | Input LOW voltage        |  | –   | 0.6              | V             |               |
| $I_{IL}$         | Input leakage current    | $V_{IN} = V_{DD}/G_{ND}$ , $V_{DD} = \text{max.}$ (REF and FB inputs)  | –5  | 5                | $\mu\text{A}$ |               |
| $I_3$            | 3-level input DC current | HIGH, $V_{IN} = V_{DD}$  | 3-level inputs<br>(TEST, FS, nF[1:0],<br>DS[1:0], PD#/DIV, PE/HD) | –                | 200           | $\mu\text{A}$ |
|                  |                          | MID, $V_{IN} = V_{DD}/2$   |   | –50              | 50            | $\mu\text{A}$ |
|                  |                          | LOW, $V_{IN} = V_{SS}$   |   | –200             | –             | $\mu\text{A}$ |
| $I_{PU}$         | Input pull-up current    | $V_{IN} = V_{SS}$ , $V_{DD} = \text{max.}$   | –100  | –                | $\mu\text{A}$ |               |
| $I_{PD}$         | Input pull-down current  | $V_{IN} = V_{DD}$ , $V_{DD} = \text{max.}$ , (sOE#)  | –   | 100              | $\mu\text{A}$ |               |
| $V_{OL}$         | Output LOW voltage       | $I_{OL} = 12 \text{ mA}$ (PE/HD = L/H), (nQ[0:1])  | –   | 0.4              | V             |               |
|                  |                          | $I_{OL} = 24 \text{ mA}$ (PE/HD = MID), (nQ[0:1])  | –   | 0.4              | V             |               |
| $V_{OH}$         | Output HIGH voltage      | $I_{OH} = -12 \text{ mA}$ (PE/HD = L/H), (nQ[0:1])   | 2.4   | –                | V             |               |
|                  |                          | $I_{OH} = -24 \text{ mA}$ (PE/HD = MID), (nQ[0:1])   | 2.4   | –                | V             |               |
| $I_{DDQ}$        | Quiescent supply current | $V_{DD} = \text{max.}$ , TEST = MID, REF = LOW, sOE# = LOW, outputs not loaded                                 | –   | 2                | mA            |               |
| $I_{DD}$         | Dynamic supply current   | At 100 MHz   | 230   |                  | mA            |               |
| $C_{IN}$         | Input pin capacitance    |  | 4   |                  | pF            |               |

**Note**

10. These inputs are normally wired to  $V_{DD}$ , GND or unconnected. Internal termination resistors bias unconnected inputs to  $V_{DD}/2$ .



## Thermal Resistance

| Parameter <sup>[11]</sup> | Description                              | Test Conditions   | 32-pin TQFP | Unit |
|---------------------------|--|---|-------------|------|
| $\theta_{JA}$             | Thermal resistance (junction to ambient) | Test conditions follow standard test methods and procedures for measuring thermal impedance, in accordance with EIA/JESD51. | 65          | °C/W |
| $\theta_{JC}$             | Thermal resistance (junction to case)    |   | 12          | °C/W |

## AC Test Loads and Waveforms

**Figure 2. AC Test Loads**

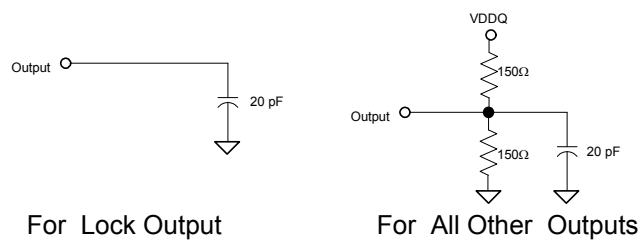

**Figure 3. Output Waveforms**

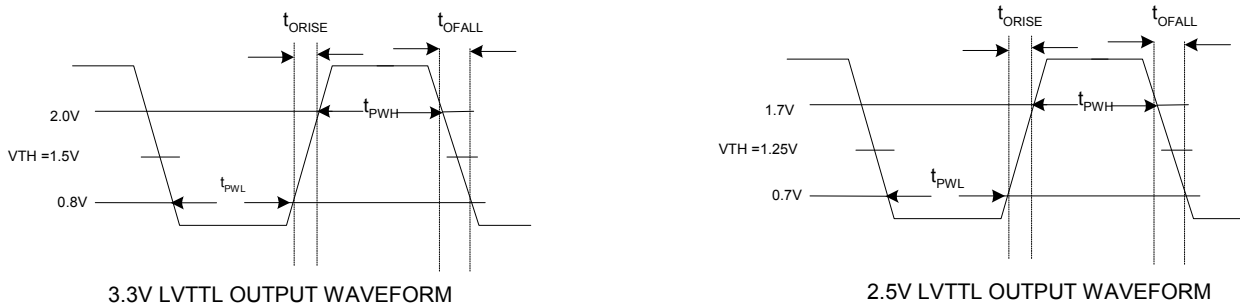

**Figure 4. Test Waveforms**

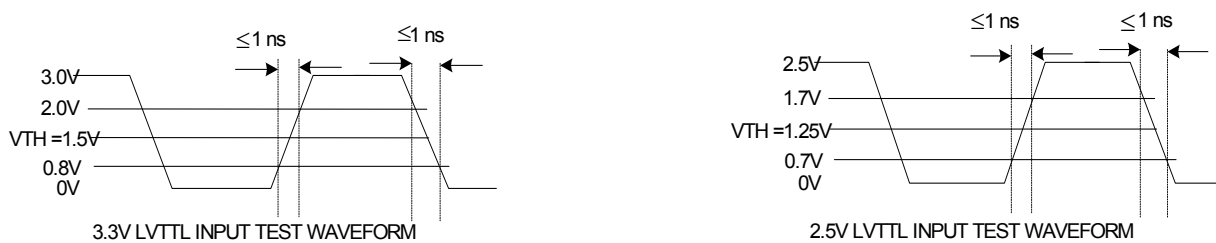

**Note**

11. These parameters are guaranteed by design and are not tested.

## AC Input Specifications

| Parameter   | Description               | Condition   | Min | Max | Unit |
|-------------|---------------------------|-------------|-----|-----|------|
| $T_{R,T_F}$ | Input rise/fall time      | 0.8 V–2.0 V | –   | 10  | ns/V |
| $T_{PWC}$   | Input clock pulse         | HIGH or LOW | 2   | –   | ns   |
| $T_{DCIN}$  | Input duty cycle          |             | 10  | 90  | %    |
| $F_{REF}$   | Reference input frequency | FS = LOW    | 6   | 50  | MHz  |
|             |                           | FS = MID    | 12  | 100 |      |
|             |                           | FS = HIGH   | 24  | 200 |      |

## Switching Characteristics

| Parameter                      | Description                              | Condition   | Min  | Typ       | Max  | Unit |
|--------------------------------|--|---|------|-----------|------|------|
| F <sub>OR</sub>                | Output frequency range                   |   | 6    | –         | 200  | MHz  |
| VCO <sub>LR</sub>              | VCO lock range                           |   | 200  | –         | 400  | MHz  |
| VCO <sub>LBW</sub>             | VCO loop bandwidth                       |   | 0.25 | –         | 3.5  | MHz  |
| t <sub>SKEWPR</sub>            | Matched-pair skew <sup>[10]</sup>        | Skew between the earliest and the latest output transitions within the same bank.   | –    | 50        | 100  | ps   |
| t <sub>SKEW0</sub>             | Output-output skew <sup>[10]</sup>       | Skew between the earliest and the latest output transitions among all outputs at 0t <sub>U</sub> .  | –    | 100       | 200  | ps   |
| t <sub>SKEW1</sub>             |  | Skew between the earliest and the latest output transitions among all outputs for which the same phase delay has been selected.                             | –    | 100       | 200  | ps   |
| t <sub>SKEW2</sub>             |  | Skew between the nominal output rising edge to the inverted output falling edge.  | –    | –         | 500  | ps   |
| t <sub>SKEW3</sub>             | Output-output skew <sup>[10]</sup>       | Skew between non-inverted outputs running at different frequencies.   | –    | –         | 500  | ps   |
| t <sub>SKEW4</sub>             |  | Skew between nominal to inverted outputs running at different frequencies.  | –    | –         | 500  | ps   |
| t <sub>SKEW5</sub>             |  | Skew between nominal outputs at different power supply levels.  | –    | –         | 650  | ps   |
| t <sub>PART</sub>              | Part-part skew                           | Skew between the outputs of any two devices under identical settings and conditions (V <sub>DDQ</sub> , V <sub>DD</sub> , temp, air flow, frequency, etc.). | –    | –         | 750  | ps   |
| t <sub>PD0</sub>               | Ref-FB propagation delay <sup>[11]</sup> |   | –250 | –         | +250 | ps   |
| t <sub>ODCV</sub>              | Output duty cycle                        | F <sub>out</sub> < 100 MHz, measured at V <sub>DD</sub> /2  | 48   | 49.5/50.5 | 52   | %    |
|                                |  | F <sub>out</sub> > 100 MHz, measured at V <sub>DD</sub> /2  | 45   | 48/52     | 55   |      |
| t <sub>PWH</sub>               | Output high time deviation from 50%      | Measured at 2.0V for V <sub>DD</sub> = 3.3 V and at 1.7 V for V <sub>DD</sub> = 2.5V.   | –    | –         | 1.5  | ns   |
| t <sub>PWL</sub>               | Output low time deviation from 50%       | Measured at 0.8 V for V <sub>DD</sub> = 3.3 V and at 0.7 V for V <sub>DD</sub> = 2.5 V.   | –    | –         | 2.0  | ns   |
| t <sub>R</sub> /t <sub>F</sub> | Output rise/fall time                    | Measured at 0.8 V–2.0 V for V <sub>DD</sub> = 3.3 V and 0.7 V–1.7 V for V <sub>DD</sub> = 2.5 V.  | 0.15 | –         | 1.5  | ns   |
| t <sub>LOCK</sub>              | PLL lock time <sup>[12,13]</sup>         |   | –    | –         | 0.5  | ms   |
| t <sub>CCJ</sub>               | Cycle-cycle jitter                       | Divide by one output frequency, FS = L, FB = divide by 1, 2, 4.   | –    | 50        | 100  | ps   |
|                                |  | Divide by one output frequency, FS = M/H, FB = divide by 1, 2, 4.   | –    | 70        | 150  | ps   |

### Notes

10. Test load = 20 pF, terminated to V<sub>CC</sub>/2. All outputs are equally loaded.

11. t<sub>PD</sub> is measured at 1.5 V for V<sub>DD</sub> = 3.3 V and at 1.25 V for V<sub>DD</sub> = 2.5 V with REF rise/fall times of 0.5 ns between 0.8 V–2.0 V.

12. t<sub>LOCK</sub> is the time that is required before outputs synchronize to REF. This specification is valid with stable power supplies which are within normal operating limits.

13. Lock detector circuit may be unreliable for input frequencies lower than 4 MHz, or for input signals which contain significant jitter.

**AC Timing Definitions**

**Figure 5. Timing Definitions**

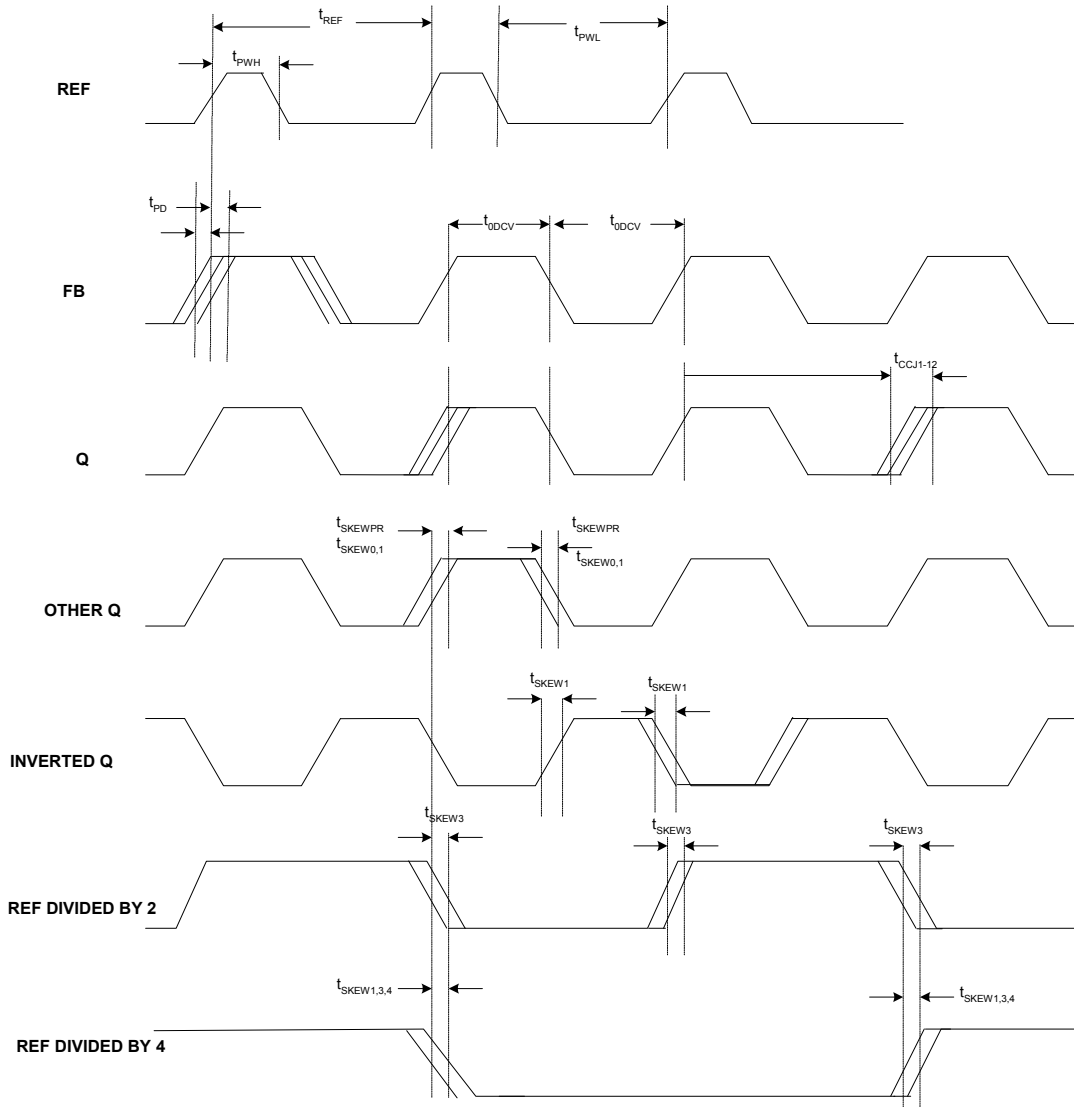

**Ordering Information**

| Part Number             | Package Type                | Product Flow                |
|-------------------------|-----------------------------|-----------------------------|
| <b>Pb-free</b>          |                             |                             |
| CY7B9950 RoboClock®AXC  | 32-pin TQFP                 | Commercial, 0° to 70 °C     |
| CY7B9950 RoboClock®AXCT | 32-pin TQFP – Tape and Reel | Commercial, 0° to 70 °C     |
| CY7B9950 RoboClock®AXI  | 32-pin TQFP                 | Industrial, –40 °C to 85 °C |
| CY7B9950 RoboClock®AXIT | 32-pin TQFP – Tape and Reel | Industrial, –40 °C to 85 °C |

**Ordering Code Definitions**

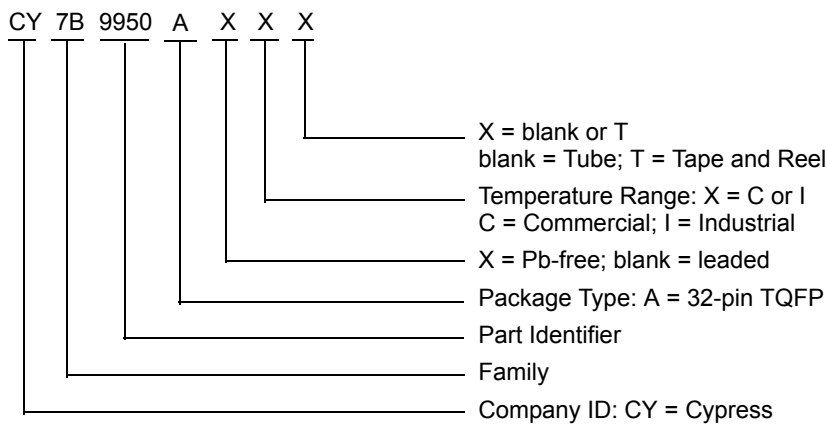

Package Diagram

Figure 6. 32-pin TQFP (7 × 7 × 1.0 mm) A3210 Package Outline, 51-85063

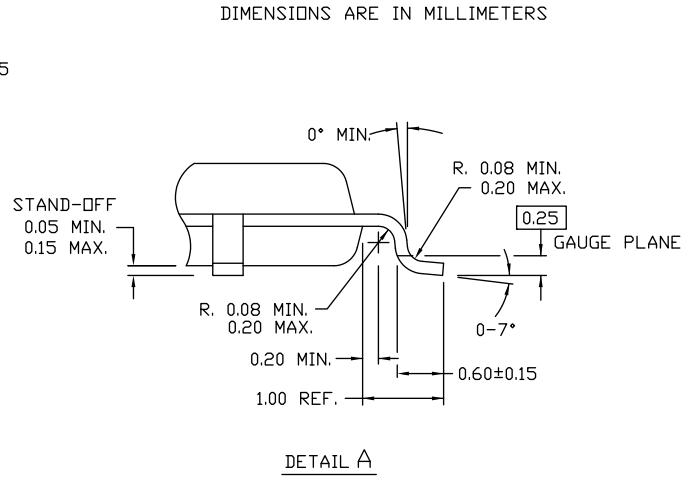
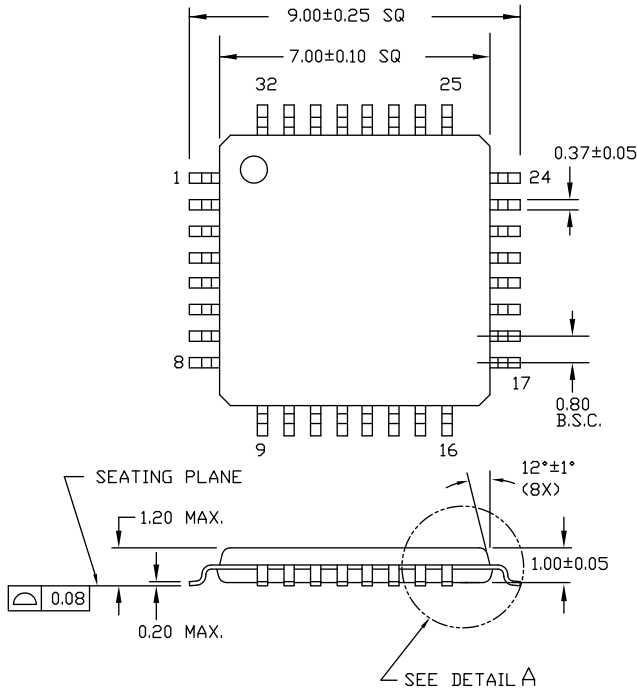

51-85063 \*E

## Acronyms

**Table 9. Acronyms Used in this Document**

| Acronym | Description                             |
|---------|---|
| CLKOUT  | Clock Output                            |
| CMOS    | Complementary Metal Oxide Semiconductor |
| DPM     | Die Pick Map                            |
| EPROM   | Erasable Programmable Read Only Memory  |
| NTSC    | National Television System Committee    |
| OE      | Output Enable                           |
| PAL     | Phase Alternate Line                    |
| PD      | Power Down                              |
| PLL     | Phase Locked Loop                       |
| PPM     | Parts Per Million                       |
| TTL     | Transistor-Transistor Logic             |

## Document Conventions

### Units of Measure

**Table 10. Units of Measure**

| Symbol | Unit of Measure             | Symbol | Unit of Measure               |
|--------|-----------------------------|--------|-------------------------------|
| °C     | degree Celsius              | μW     | microwatt                     |
| dB     | decibel                     | mA     | milliampere                   |
| fC     | femtoCoulomb                | mm     | millimeter                    |
| fF     | femtofarad                  | ms     | millisecond                   |
| Hz     | hertz                       | mV     | millivolt                     |
| KB     | 1024 bytes                  | nA     | nanoampere                    |
| Kbit   | 1024 bits                   | ns     | nanosecond                    |
| kHz    | kilohertz                   | nV     | nanovolt                      |
| kΩ     | kilohm                      | Ω      | ohm                           |
| MHz    | megahertz                   | pA     | picoampere                    |
| MΩ     | megaohm                     | pF     | picofarad                     |
| μA     | microampere                 | pp     | peak-to-peak                  |
| μF     | microfarad                  | ppm    | parts per million             |
| μH     | microhenry                  | ps     | picosecond                    |
| μs     | microsecond                 | sps    | samples per second            |
| μV     | microvolt                   | σ      | sigma: one standard deviation |
| μVrms  | microvolts root-mean-square |        |                               |

**Document History Page**

| Document Title: CY7B9950 RoboClock®, 2.5/3.3 V, 200 MHz High-Speed Multi-Phase PLL Clock Buffer<br>Document Number: 38-07338 |         |                 |                 |   |
|--|---------|-----------------|-----------------|---|
| Rev.   | ECN No. | Submission Date | Orig. of Change | Description of Change   |
| **   | 121663  | 11/25/02        | RGL             | New data sheet.   |
| *A   | 122548  | 12/12/02        | RGL             | Updated <a href="#">DC Electrical Specifications at 2.5 V</a> :<br>Updated details in “Condition” column corresponding to $V_{IH}$ , $V_{IMM}$ and $V_{ILL}$ parameters (Removed PD#/DIV and DS[1:0]).<br>Updated <a href="#">DC Electrical Specifications at 3.3 V</a> :<br>Updated details in “Condition” column corresponding to $V_{IH}$ , $V_{IMM}$ and $V_{ILL}$ parameters (Removed PD#/DIV and DS[1:0]).  |
| *B   | 124646  | 03/05/03        | RGL             | Updated <a href="#">Pin Definitions</a> :<br>Updated details in “Description” column corresponding to pin 27 and pin 12.<br>Updated <a href="#">Absolute Maximum Conditions</a> :<br>Changed minimum value of $V_{DD}$ parameter corresponding to Test Condition “Functional @ 2.5V ± 5%” from 2.25 V to 2.375 V.<br>Changed maximum value of $V_{DD}$ parameter corresponding to Test Condition “Functional @ 2.5V ± 5%” from 2.75 V to 2.625 V.   |
| *C   | 433662  | See ECN         | RGL             | Updated <a href="#">Features</a> :<br>Updated details corresponding to “Output-output skew” and “Cycle-cycle jitter”.<br>Updated <a href="#">Switching Characteristics</a> :<br>Added a column “Typ”.<br>Updated <a href="#">Ordering Information</a> :<br>Updated part numbers.  |
| *D   | 1562063 | See ECN         | PYG / AESA      | Updated <a href="#">Ordering Information</a> :<br>Updated part numbers.<br>Added a column “Status”.   |
| *E   | 2894960 | 03/17/10        | KVM             | Updated <a href="#">Device Configuration</a> :<br>Updated <a href="#">Table 5</a> :<br>Fixed typo in output skew settings.<br>Updated <a href="#">Absolute Maximum Conditions</a> :<br>Updated $V_{DD}$ value.<br>Added <a href="#">Operating Conditions</a> .<br>Updated <a href="#">Ordering Information</a> :<br>Updated part numbers.<br>Removed the column “Status”.<br>Updated <a href="#">Package Diagram</a> .<br>Updated <a href="#">Sales, Solutions, and Legal Information</a> :<br>Updated links. |
| *F   | 3058099 | 10/14/10        | BASH            | Added <a href="#">Ordering Code Definitions</a> .<br>Added <a href="#">Acronyms</a> and <a href="#">Units of Measure</a> .<br>Updated to new template.  |
| *G   | 4176123 | 10/28/2013      | CINM            | Updated <a href="#">Package Diagram</a> :<br>spec 51-85063 – Changed revision from *C to *D.<br>Updated to new template.<br>Completing Sunset Review.   |
| *H   | 4571728 | 11/17/2014      | CINM            | Updated <a href="#">Functional Description</a> :<br>Added “For a complete list of related documentation, <a href="#">click here</a> .” at the end.  |
| *I   | 4764256 | 05/13/2015      | XHT             | Updated <a href="#">Absolute Maximum Conditions</a> :<br>Changed value of MSL parameter from 1 to 3.<br>Updated <a href="#">Package Diagram</a> :<br>spec 51-85063 – Changed revision from *D to *E.  |
| *J   | 5257087 | 05/03/2016      | PSR             | Added <a href="#">Thermal Resistance</a> .<br>Updated to new template.  |



**Document History Page(continued)**

| <b>Document Title: CY7B9950 RoboClock®, 2.5/3.3 V, 200 MHz High-Speed Multi-Phase PLL Clock Buffer</b> |                |                        |                        |   |
|--|----------------|------------------------|------------------------|---|
| <b>Document Number: 38-07338</b>   |                |                        |                        |   |
| <b>Rev.</b>  | <b>ECN No.</b> | <b>Submission Date</b> | <b>Orig. of Change</b> | <b>Description of Change</b>                          |
| *K   | 5493833        | 10/25/2016             | XHT                    | Updated to new template.<br>Completing Sunset Review. |
| *L   | 5992901        | 12/13/2017             | AESATMP8               | Updated logo and Copyright.                           |

## Sales, Solutions, and Legal Information

### Worldwide Sales and Design Support

Cypress maintains a worldwide network of offices, solution centers, manufacturer's representatives, and distributors. To find the office closest to you, visit us at [Cypress Locations](#).

#### Products

|   |  |
|---|--|
| ARM <sup>®</sup> Cortex <sup>®</sup> Microcontrollers | <a href="http://cypress.com/arm">cypress.com/arm</a>               |
| Automotive  | <a href="http://cypress.com/automotive">cypress.com/automotive</a> |
| Clocks & Buffers                                      | <a href="http://cypress.com/clocks">cypress.com/clocks</a>         |
| Interface   | <a href="http://cypress.com/interface">cypress.com/interface</a>   |
| Internet of Things                                    | <a href="http://cypress.com/iot">cypress.com/iot</a>               |
| Memory  | <a href="http://cypress.com/memory">cypress.com/memory</a>         |
| Microcontrollers                                      | <a href="http://cypress.com/mcu">cypress.com/mcu</a>               |
| PSoC  | <a href="http://cypress.com/psoc">cypress.com/psoc</a>             |
| Power Management ICs                                  | <a href="http://cypress.com/pmhc">cypress.com/pmhc</a>             |
| Touch Sensing   | <a href="http://cypress.com/touch">cypress.com/touch</a>           |
| USB Controllers                                       | <a href="http://cypress.com/usb">cypress.com/usb</a>               |
| Wireless Connectivity                                 | <a href="http://cypress.com/wireless">cypress.com/wireless</a>     |

#### PSoC<sup>®</sup> Solutions

[PSoC 1](#) | [PSoC 3](#) | [PSoC 4](#) | [PSoC 5LP](#) | [PSoC 6](#)

#### Cypress Developer Community

[Forums](#) | [WICED IOT Forums](#) | [Projects](#) | [Video](#) | [Blogs](#) | [Training](#) | [Components](#)

#### Technical Support

[cypress.com/support](http://cypress.com/support)

© Cypress Semiconductor Corporation, 2002-2017. This document is the property of Cypress Semiconductor Corporation and its subsidiaries, including Spansion LLC ("Cypress"). This document, including any software or firmware included or referenced in this document ("Software"), is owned by Cypress under the intellectual property laws and treaties of the United States and other countries worldwide. Cypress reserves all rights under such laws and treaties and does not, except as specifically stated in this paragraph, grant any license under its patents, copyrights, trademarks, or other intellectual property rights. If the Software is not accompanied by a license agreement and you do not otherwise have a written agreement with Cypress governing the use of the Software, then Cypress hereby grants you a personal, non-exclusive, nontransferable license (without the right to sublicense) (1) under its copyright rights in the Software (a) for Software provided in source code form, to modify and reproduce the Software solely for use with Cypress hardware products, only internally within your organization, and (b) to distribute the Software in binary code form externally to end users (either directly or indirectly through resellers and distributors), solely for use on Cypress hardware product units, and (2) under those claims of Cypress's patents that are infringed by the Software (as provided by Cypress, unmodified) to make, use, distribute, and import the Software solely for use with Cypress hardware products. Any other use, reproduction, modification, translation, or compilation of the Software is prohibited.

TO THE EXTENT PERMITTED BY APPLICABLE LAW, CYPRESS MAKES NO WARRANTY OF ANY KIND, EXPRESS OR IMPLIED, WITH REGARD TO THIS DOCUMENT OR ANY SOFTWARE OR ACCOMPANYING HARDWARE, INCLUDING, BUT NOT LIMITED TO, THE IMPLIED WARRANTIES OF MERCHANTABILITY AND FITNESS FOR A PARTICULAR PURPOSE. To the extent permitted by applicable law, Cypress reserves the right to make changes to this document without further notice. Cypress does not assume any liability arising out of the application or use of any product or circuit described in this document. Any information provided in this document, including any sample design information or programming code, is provided only for reference purposes. It is the responsibility of the user of this document to properly design, program, and test the functionality and safety of any application made of this information and any resulting product. Cypress products are not designed, intended, or authorized for use as critical components in systems designed or intended for the operation of weapons, weapons systems, nuclear installations, life-support devices or systems, other medical devices or systems (including resuscitation equipment and surgical implants), pollution control or hazardous substances management, or other uses where the failure of the device or system could cause personal injury, death, or property damage ("Unintended Uses"). A critical component is any component of a device or system whose failure to perform can be reasonably expected to cause the failure of the device or system, or to affect its safety or effectiveness. Cypress is not liable, in whole or in part, and you shall and hereby do release Cypress from any claim, damage, or other liability arising from or related to all Unintended Uses of Cypress products. You shall indemnify and hold Cypress harmless from and against all claims, costs, damages, and other liabilities, including claims for personal injury or death, arising from or related to any Unintended Uses of Cypress products.

Cypress, the Cypress logo, Spansion, the Spansion logo, and combinations thereof, WICED, PSoC, CapSense, EZ-USB, F-RAM, and Traveo are trademarks or registered trademarks of Cypress in the United States and other countries. For a more complete list of Cypress trademarks, visit [cypress.com](http://cypress.com). Other names and brands may be claimed as property of their respective owners.