

## 512Kx16 LOW VOLTAGE, ULTRA LOW POWER CMOS STATIC RAM

### KEY FEATURES

- High-speed access time: 45ns, 55ns
- CMOS low power operation  
– 36 mW (typical) operating
- TTL compatible interface levels
- Single power supply  
– 1.65V—2.2V V<sub>DD</sub> (62/65WV51216EALL)  
– 2.2V--3.6V V<sub>DD</sub> (62/65WV51216EBLL)
- Data control for upper and lower bytes
- Automotive temperature (-40°C to +125°C)

### DESCRIPTION

The *ISSI* IS62WV51216EALL/ IS62WV51216EBLL are high-speed, 8M bit static RAMs organized as 512K words by 16 bits. It is fabricated using *ISSI*'s high-performance CMOS technology. This highly reliable process coupled with innovative circuit design techniques, yields high-performance and low power consumption devices.

When CS<sub>1</sub> is HIGH (deselected) or when CS<sub>2</sub> is low (deselected) or when CS<sub>1</sub> is low, CS<sub>2</sub> is high and both LB and UB are HIGH, the device assumes a standby mode at which the power dissipation can be reduced down with CMOS input levels.

Easy memory expansion is provided by using Chip Enable and Output Enable inputs. The active LOW Write Enable ( $\overline{WE}$ ) controls both writing and reading of the memory. A data byte allows Upper Byte ( $\overline{UB}$ ) and Lower Byte ( $\overline{LB}$ ) access.

The IS62WV51216EALL and IS62WV51216EBLL are packaged in the JEDEC standard 48-pin mini BGA (6mm x8mm), 44-Pin TSOP (TYPE II) and 48-pin TSOP (TYPE I).

### BLOCK DIAGRAM

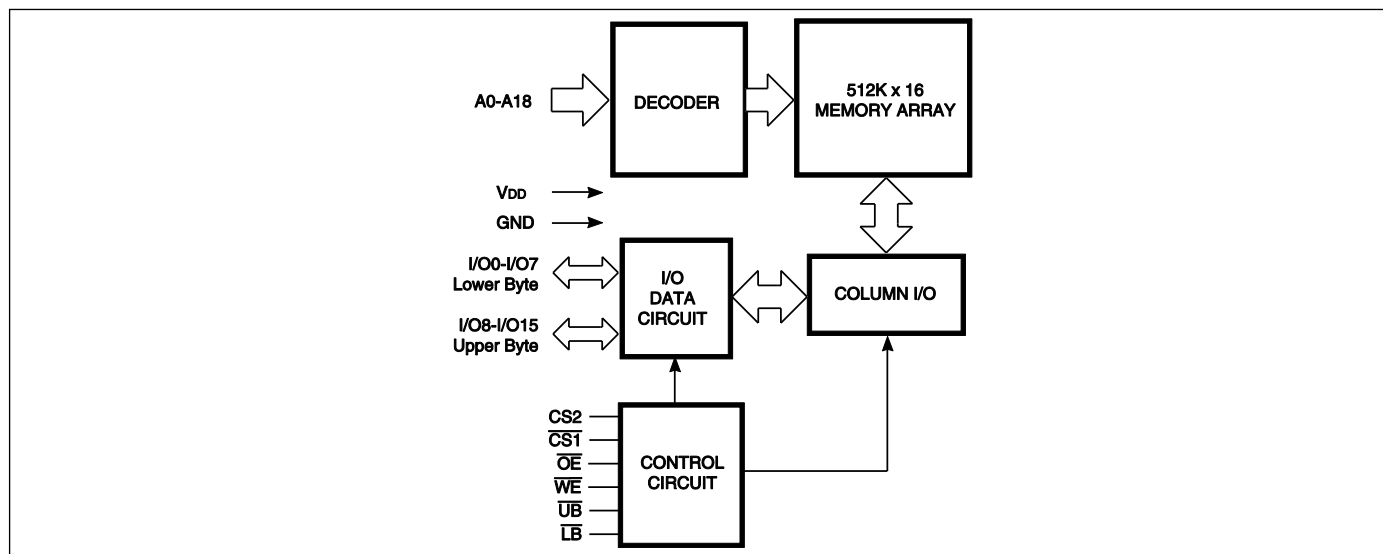

Copyright © 2016 Integrated Silicon Solution, Inc. All rights reserved. ISSI reserves the right to make changes to this specification and its products at any time without notice. ISSI assumes no liability arising out of the application or use of any information, products or services described herein. Customers are advised to obtain the latest version of this device specification before relying on any published information and before placing orders for products.

Integrated Silicon Solution, Inc. does not recommend the use of any of its products in life support applications where the failure or malfunction of the product can reasonably be expected to cause failure of the life support system or to significantly affect its safety or effectiveness. Products are not authorized for use in such applications unless Integrated Silicon Solution, Inc. receives written assurance to its satisfaction, that:

- a.) the risk of injury or damage has been minimized;
- b.) the user assume all such risks; and
- c.) potential liability of Integrated Silicon Solution, Inc is adequately protected under the circumstances

**PIN CONFIGURATIONS (512Kx16)**

48-Pin mini BGA (6mm x 8mm)

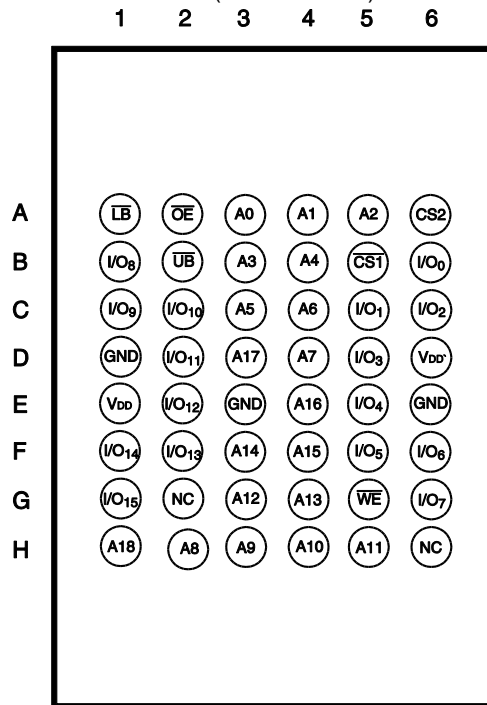

44-Pin TSOP (Type II)

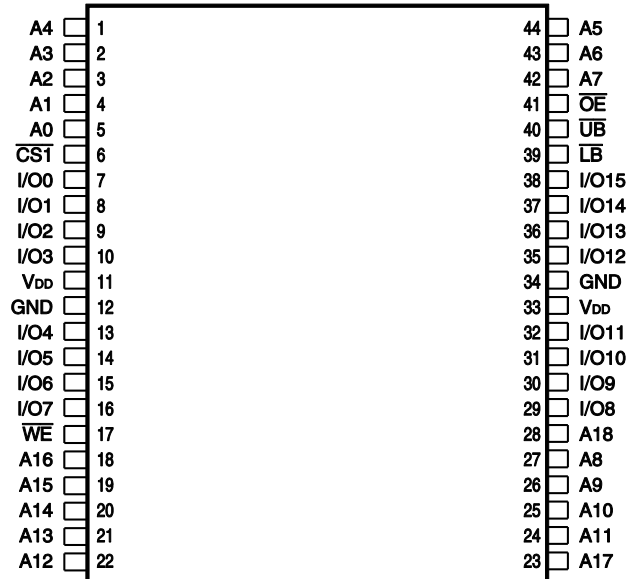

2 CS Option (Package Code T2)  
 48-pin TSOP-I (12mm x 20mm)

**PIN DESCRIPTIONS**

A0-A18	Address Inputs
I/O0-I/O15	Data Inputs/Outputs
CS1, CS2	Chip Enable Input
OE	Output Enable Input
WE	Write Enable Input
LB	Lower-byte Control (I/O0-I/O7)
UB	Upper-byte Control (I/O8-I/O15)
NC	No Connection
VDD	Power
GND	Ground



## FUNCTION DESCRIPTION

SRAM is one of random access memories. Each byte or word has an address and can be accessed randomly. SRAM has three different modes supported. Each function is described below with Truth Table.

### STANDBY MODE

Device enters standby mode when deselected ( $\overline{CS1}$  HIGH or CS2 LOW or both  $\overline{UB}$  and  $\overline{LB}$  are HIGH). The input and output pins (I/O0-15) are placed in a high impedance state. The current consumption in this mode will be either ISB1 or ISB2 depending on the input level. CMOS input in this mode will maximize saving power.

### WRITE MODE

Write operation issues with Chip selected ( $\overline{CS1}$  LOW and CS2 HIGH) and Write Enable ( $\overline{WE}$ ) input LOW. The input and output pins(I/O0-15) are in data input mode. Output buffers are closed during this time even if  $\overline{OE}$  is LOW.  $\overline{UB}$  and  $\overline{LB}$  enables a byte write feature. By enabling  $\overline{LB}$  LOW, data from I/O pins (I/O0 through I/O7) are written into the location specified on the address pins. And with  $\overline{UB}$  being LOW, data from I/O pins (I/O8 through I/O15) are written into the location.

### READ MODE

Read operation issues with Chip selected ( $\overline{CS1}$  LOW and CS2 HIGH) and Write Enable ( $\overline{WE}$ ) input HIGH. When  $\overline{OE}$  is LOW, output buffer turns on to make data output. Any input to I/O pins during READ mode is not permitted.  $\overline{UB}$  and  $\overline{LB}$  enables a byte read feature. By enabling  $\overline{LB}$  LOW, data from memory appears on I/O0-7. And with  $\overline{UB}$  being LOW, data from memory appears on I/O8-15.

In the READ mode, output buffers can be turned off by pulling  $\overline{OE}$  HIGH. In this mode, internal device operates as READ but I/Os are in a high impedance state. Since device is in READ mode, active current is used.

## TRUTH TABLE

Mode	$\overline{CS1}$	CS2	$\overline{WE}$	$\overline{OE}$	$\overline{LB}$	$\overline{UB}$	I/O0-I/O7	I/O8-I/O15	VDD Current
Not Selected	H	X	X	X	X	X	High-Z	High-Z	ISB1,ISB2
	X	L	X	X	X	X	High-Z	High-Z	
	X	X	X	X	H	H	High-Z	High-Z	
Output Disabled	L	H	H	H	L	X	High-Z	High-Z	ICC
	L	H	H	H	X	L	High-Z	High-Z	
Read	L	H	H	L	L	H	DOUT	High-Z	ICC
	L	H	H	L	H	L	High-Z	DOUT	
	L	H	H	L	L	L	DOUT	DOUT	
Write	L	H	L	X	L	H	DIN	High-Z	ICC
	L	H	L	X	H	L	High-Z	DIN	
	L	H	L	X	L	L	DIN	DIN	

**ABSOLUTE MAXIMUM RATINGS AND OPERATING RANGE**

**ABSOLUTE MAXIMUM RATINGS<sup>(1)</sup>**

Symbol	Parameter	Value	Unit
V <sub>term</sub>	Terminal Voltage with Respect to GND	-0.2 to +3.9(V <sub>DD</sub> +0.3V)	V
t <sub>BIAS</sub>	Temperature Under Bias	-55 to +125	°C
V <sub>DD</sub>	V <sub>DD</sub> Related to GND	-0.2 to +3.9(V <sub>DD</sub> +0.3V)	V
t <sub>Stg</sub>	Storage Temperature	-65 to +150	°C
I <sub>OUT</sub>	DC Output Current (LOW)	20	mA

Notes:

1. Stress greater than those listed under ABSOLUTE MAXIMUM RATINGS may cause permanent damage to the device. This is a stress rating only and functional operation of the device at these or any other conditions above those indicated in the operational sections of this specification is not implied. Exposure to absolute maximum rating conditions for extended periods may affect reliability.

**OPERATING RANGE<sup>(1)</sup>**

Range	Device Marking	Ambient Temperature	V <sub>DD</sub> (min)	V <sub>DD</sub> (typ)	V <sub>DD</sub> (max)
Commercial	IS62WV51216EALL	0°C to +70°C	1.65V	1.8V	2.2V
Industrial	IS62WV51216EALL	-40°C to +85°C	1.65V	1.8V	2.2V
Automotive	IS65WV51216EALL	-40°C to +125°C	1.65V	1.8V	2.2V
Commercial	IS62WV51216EBLL	0°C to +70°C	2.2V	3.3V	3.6V
Industrial	IS62WV51216EBLL	-40°C to +85°C	2.2V	3.3V	3.6V
Automotive	IS65WV51216EBLL	-40°C to +125°C	2.2V	3.3V	3.6V

Note:

1. Full device AC operation assumes a 100 μs ramp time from 0 to V<sub>cc</sub>(min) and 200 μs wait time after V<sub>cc</sub> stabilization.

**PIN CAPACITANCE<sup>(1)</sup>**

Parameter	Symbol	Test Condition	Max	Units
Input capacitance	C <sub>IN</sub>	T <sub>A</sub> = 25°C, f = 1 MHz, V <sub>DD</sub> = V <sub>DD</sub> (typ)	10	pF
DQ capacitance (IO0–IO15)	C <sub>I/O</sub>		10	pF

Note:

1. These parameters are guaranteed by design and tested by a sample basis only.

**THERMAL CHARACTERISTICS<sup>(1)</sup>**

Parameter	Package	Symbol	Rating	Units
Thermal resistance from junction to ambient (airflow = 0m/s)	44-pin TSOP-II	R <sub>θJA</sub>	51.8	°C/W
	48-ball VFBGA		48.05	
Thermal resistance from junction to case (airflow = 0m/s)	44-pin TSOP-II	R <sub>θJC</sub>	9.6	°C/W
	48-ball VFBGA		13.35	

Note:

1. These parameters are guaranteed by design and tested by a sample basis only.

**ELECTRICAL CHARACTERISTICS**

**IS62(5)WV51216EALL DC ELECTRICAL CHARACTERISTICS-I (OVER THE OPERATING RANGE)**

Symbol	Parameter	Test Conditions	Min.	Max.	Unit
$V_{OH}$	Output HIGH Voltage	$I_{OH} = -0.1 \text{ mA}$	1.4	—	V
$V_{OL}$	Output LOW Voltage	$I_{OL} = 0.1 \text{ mA}$	—	0.2	V
$V_{IH}^{(1)}$	Input HIGH Voltage		1.4	$V_{DD} + 0.2$	V
$V_{IL}^{(1)}$	Input LOW Voltage		-0.2	0.4	V
$I_{LI}$	Input Leakage	$GND < V_{IN} < V_{DD}$	-1	1	$\mu\text{A}$
$I_{LO}$	Output Leakage	$GND < V_{IN} < V_{DD}$ , Output Disabled	-1	1	$\mu\text{A}$

Notes:

- $V_{ILL}(\text{min}) = -1.0\text{V AC}$  (pulse width < 10ns). Not 100% tested.  
 $V_{IHH}(\text{max}) = V_{DD} + 1.0\text{V AC}$  (pulse width < 10ns). Not 100% tested.

**IS62(5)WV51216EBLL DC ELECTRICAL CHARACTERISTICS-I (OVER THE OPERATING RANGE)**

Symbol	Parameter	Test Conditions	Min.	Max.	Unit
$V_{OH}$	Output HIGH Voltage	$2.2 \leq V_{DD} < 2.7$ , $I_{OH} = -0.1 \text{ mA}$	2.0	—	V
		$2.7 \leq V_{DD} \leq 3.6$ , $I_{OH} = -1.0 \text{ mA}$	2.4	—	V
$V_{OL}$	Output LOW Voltage	$2.2 \leq V_{DD} < 2.7$ , $I_{OL} = 0.1 \text{ mA}$	—	0.4	V
		$2.7 \leq V_{DD} \leq 3.6$ , $I_{OL} = 2.1 \text{ mA}$	—	0.4	V
$V_{IH}^{(1)}$	Input HIGH Voltage	$2.2 \leq V_{DD} < 2.7$	1.8	$V_{DD} + 0.3$	V
		$2.7 \leq V_{DD} \leq 3.6$	2.2	$V_{DD} + 0.3$	V
$V_{IL}^{(1)}$	Input LOW Voltage	$2.2 \leq V_{DD} < 2.7$	-0.3	0.6	V
		$2.7 \leq V_{DD} \leq 3.6$	-0.3	0.8	V
$I_{LI}$	Input Leakage	$GND < V_{IN} < V_{DD}$	-1	1	$\mu\text{A}$
$I_{LO}$	Output Leakage	$GND < V_{IN} < V_{DD}$ , Output Disabled	-1	1	$\mu\text{A}$

Notes:

- $V_{ILL}(\text{min}) = -2.0\text{V AC}$  (pulse width < 10ns). Not 100% tested.  
 $V_{IHH}(\text{max}) = V_{DD} + 2.0\text{V AC}$  (pulse width < 10ns). Not 100% tested.

**IS62(5)WV51216EALL DC ELECTRICAL CHARACTERISTICS-II FOR POWER**  
**(OVER THE OPERATING RANGE)**

Symbol	Parameter	Test Conditions	Grade	Typ. <sup>(1)</sup>	Max.	Unit	
ICC	V <sub>DD</sub> Dynamic Operating Supply Current	V <sub>DD</sub> =V <sub>DD</sub> (max), I <sub>OUT</sub> =0mA, f=f <sub>MAX</sub>	Com.	-	12	mA	
			Ind.	-	15		
			Auto.	-	15		
ICC1	V <sub>DD</sub> Static Operating Supply Current	V <sub>DD</sub> =V <sub>DD</sub> (max), I <sub>OUT</sub> = 0mA, f=0Hz	Com.	-	6	mA	
			Ind.	-	6		
			Auto.	-	6		
ISB2	CMOS Standby Current (CMOS Inputs)	V <sub>DD</sub> =V <sub>DD</sub> (max), (1) 0V ≤ CS2 ≤ 0.2V or (2) $\overline{CS1} \geq V_{DD} - 0.2V$ , CS2 ≥ V <sub>DD</sub> - 0.2V or (3) $\overline{LB}$ and $\overline{UB} \geq V_{DD} - 0.2V$ $\overline{CS1} \leq 0.2V$ , CS2 ≥ V <sub>DD</sub> - 0.2V	Com.	25°C	11.1	15	μA
				45°C	11.4	17	
				70°C	13.6	20	
			Ind./Auto A1		15.1	25	
			Auto. A3		28.4	50	

Note:

1. Typical values are measured at VDD = 1.8V and not 100% tested.

**IS62(5)WV51216EBLL DC ELECTRICAL CHARACTERISTICS-II FOR POWER**  
**(OVER THE OPERATING RANGE)**

Symbol	Parameter	Test Conditions	Grade	Typ. <sup>(1)</sup>	Max.	Unit	
ICC	V <sub>DD</sub> Dynamic Operating Supply Current	V <sub>DD</sub> =V <sub>DD</sub> (max), I <sub>OUT</sub> =0mA, f=f <sub>MAX</sub>	Com.	-	15	mA	
			Ind.	-	15		
			Auto.	-	15		
ICC1	V <sub>DD</sub> Static Operating Supply Current	V <sub>DD</sub> =V <sub>DD</sub> (max), I <sub>OUT</sub> = 0mA, f=0Hz	Com.	-	6	mA	
			Ind.	-	6		
			Auto.	-	6		
ISB2	CMOS Standby Current (CMOS Inputs)	V <sub>DD</sub> =V <sub>DD</sub> (max), (1) 0V ≤ CS2 ≤ 0.2V or (2) $\overline{CS1} \geq V_{DD} - 0.2V$ , CS2 ≥ V <sub>DD</sub> - 0.2V or (3) $\overline{LB}$ and $\overline{UB} \geq V_{DD} - 0.2V$ $\overline{CS1} \leq 0.2V$ , CS2 ≥ V <sub>DD</sub> - 0.2V	Com.	25°C	11.1	15	μA
				45°C	11.4	17	
				70°C	13.6	20	
			Ind./Auto A1		15.1	25	
			Auto. A3		28.4	50	

Note:

1. Typical values are measured at VDD = 3.0V, and not 100% tested.

**AC CHARACTERISTICS<sup>(6)</sup> (OVER OPERATING RANGE)**

**READ CYCLE AC CHARACTERISTICS**

Parameter	Symbol	45ns		55ns		unit	notes
		Min	Max	Min	Max		
Read Cycle Time	tRC	45	-	55	-	ns	1,5
Address Access Time	tAA	-	45	-	55	ns	1
Output Hold Time	tOHA	8	-	8	-	ns	1
$\overline{CS1}$ , CS2 Access Time	tACS1/tACS2	-	45	-	55	ns	1
$\overline{OE}$ Access Time	tDOE	-	22	-	25	ns	1
$\overline{OE}$ to High-Z Output	tHZOE	-	18	-	18	ns	2
$\overline{OE}$ to Low-Z Output	tLZOE	5	-	5	-	ns	2
$\overline{CS1}$ , CS2 to High-Z Output	tHZCS//tHZCS2	-	18	-	18	ns	2
$\overline{CS1}$ , CS2 to Low-Z Output	tLZCS/tLZCS2	10	-	10	-	ns	2
$\overline{LB}$ , $\overline{UB}$ Access Time	tBA	-	45	-	55	ns	1
$\overline{LB}$ , $\overline{UB}$ to High-Z Output	tHZB	-	18	-	18	ns	2
$\overline{LB}$ , $\overline{UB}$ to Low-Z Output	tLZB	10	-	10	-	ns	2

**WRITE CYCLE AC CHARACTERISTICS**

Parameter	Symbol	45ns		55ns		unit	notes
		Min	Max	Min	Max		
Write Cycle Time	tWC	45	-	55	-	ns	1,3,5
$\overline{CS1}$ , CS2 to Write End	tSCS1/tSCS2	35	-	40	-	ns	1,3
Address Setup Time to Write End	tAW	35	-	40	-	ns	1,3
Address Hold from Write End	tHA	0	-	0	-	ns	1,3
Address Setup Time	tSA	0	-	0	-	ns	1,3
$\overline{LB}$ , $\overline{UB}$ Valid to End of Write	tPWB	35	-	40	-	ns	1,3
$\overline{WE}$ Pulse Width	tPWE	35	-	40	-	ns	1,3,4
Data Setup to Write End	tSD	28	-	28	-	ns	1,3
Data Hold from Write End	tHD	0	-	0	-	ns	1,3
$\overline{WE}$ LOW to High-Z Output	tHZWE	-	18	-	18	ns	2,3
$\overline{WE}$ HIGH to Low-Z Output	tLZWE	10	-	10	-	ns	2,3

Notes:

1. Tested with the load in Figure 1.
2. Tested with the load in Figure 2. Transition is measured  $\pm 500$  mV from steady-state voltage. tHZOE, tHZCS, tHZB, and tHZWE transitions are measured when the output enters a high impedance state. Not 100% tested.
3. The internal write time is defined by the overlap of  $\overline{CS1}$ =LOW, CS2=HIGH, ( $\overline{UB}$  or  $\overline{LB}$ )=LOW, and  $\overline{WE}$ =LOW. All four conditions must be in valid states to initiate a Write, but any condition can go inactive to terminate the Write. The Data Input Setup and Hold timing are referenced to the rising or falling edge of the signal that terminates the write.
4. tPWE > tHZWE + tSD when OE is LOW.
5. Address inputs must meet  $V_{IH}$  and  $V_{IL}$  SPEC during this period. Any glitch or unknown inputs are not permitted. Unknown input with standby mode is acceptable.
6. Data retention characteristics are defined later in DATA RETENTION CHARACTERISTICS.

**AC TEST CONDITIONS (OVER THE OPERATING RANGE)**

Parameter	Symbol	Conditions	Units
Input Rise Time	$T_R$	1.0	V/ns
Input Fall Time	$T_F$	1.0	V/ns
Output Timing Reference Level	$V_{REF}$	$\frac{1}{2} V_{TM}$	V
Output Load Conditions	Refer to Figure 1 and 2		

**OUTPUT LOAD CONDITIONS FIGURES**

Figure1

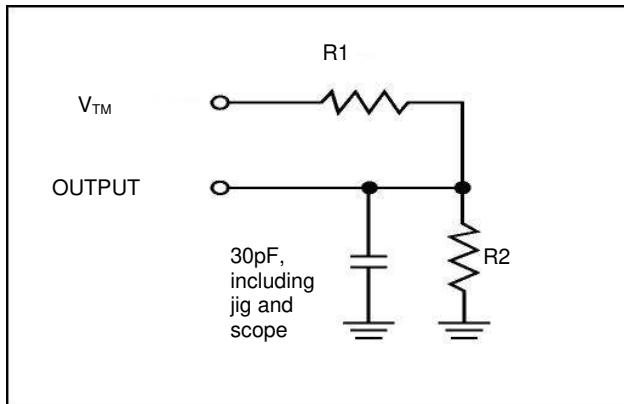
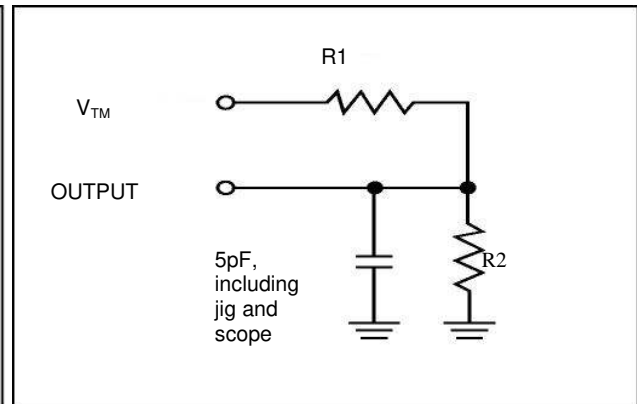

Figure2



Parameters	$V_{DD}=1.65\sim 2.2V$	$V_{DD}=2.2\sim 2.7V$	$V_{DD}=2.7\sim 3.6V$
Input Pulse Level	0.4V to $V_{DD}-0.2V$	0.4V to $V_{DD}-0.3V$	
R1	13500 $\Omega$	16667 $\Omega$	1103 $\Omega$
R2	10800 $\Omega$	15385 $\Omega$	1554 $\Omega$
$V_{TM}$	$V_{DD}$	$V_{DD}$	$V_{DD}$



**TIMING DIAGRAM**

**READ CYCLE NO. 1<sup>(1,2)</sup> (ADDRESS CONTROLLED) ( $\overline{CS1}=\overline{OE}=VIL$ ,  $CS2=\overline{WE}=VIH$ )**

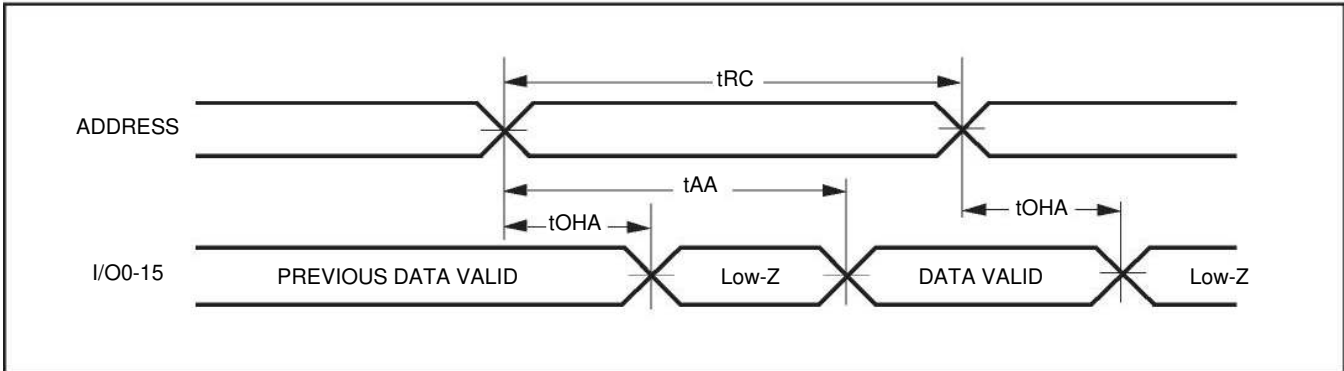

**READ CYCLE NO. 2<sup>(1,3)</sup> ( $\overline{CS1}$ ,  $CS2$ ,  $\overline{OE}$ , AND  $\overline{UB}$  &  $\overline{LB}$  CONTROLLED)**

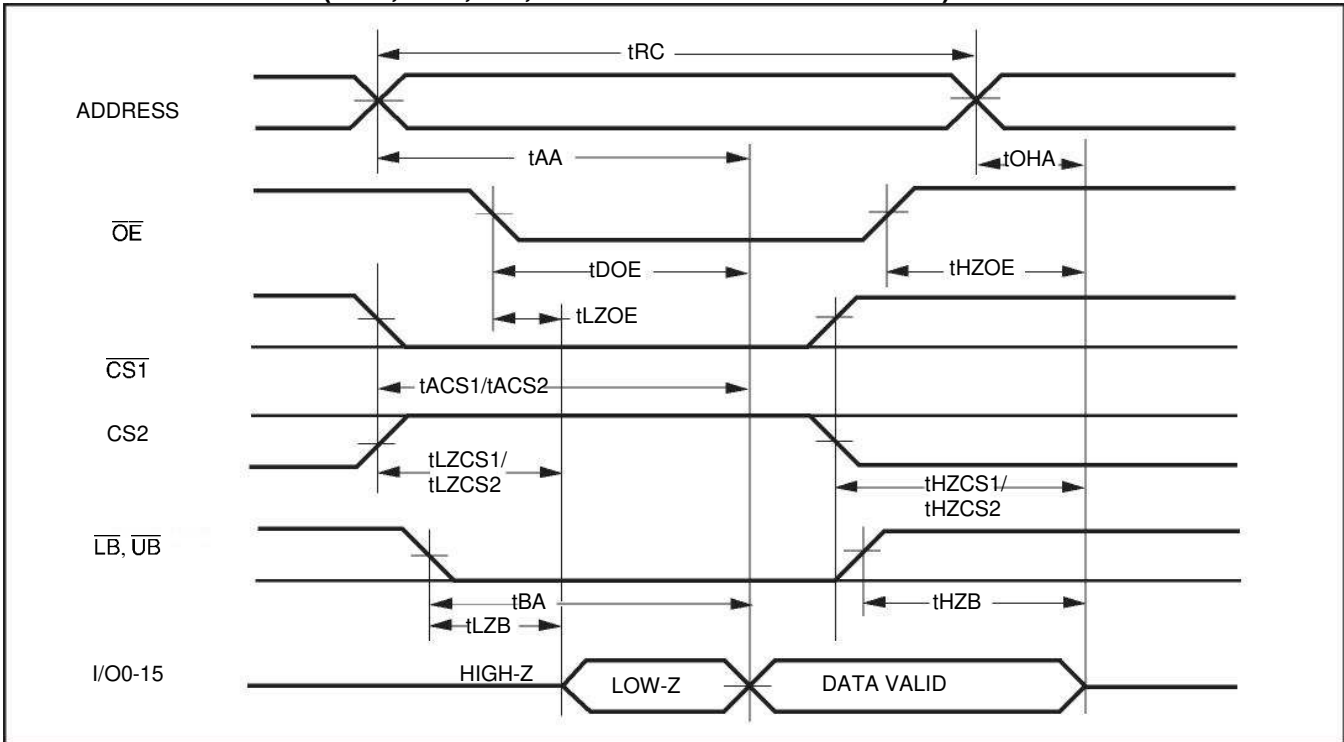

Notes:

1.  $\overline{WE}$  is HIGH for Read Cycle.
2. The device is continuously selected.  $\overline{OE}$ ,  $\overline{CS1}$ ,  $\overline{UB}$ , or  $\overline{LB}=VIL$ .  $CS2=\overline{WE}=VIH$ .
3. Address is valid prior to or coincident with  $\overline{CS1}$  LOW transition.

**WRITE CYCLE NO. 1 ( $\overline{CS1}$  CONTROLLED,  $\overline{OE}$  = HIGH OR LOW)**

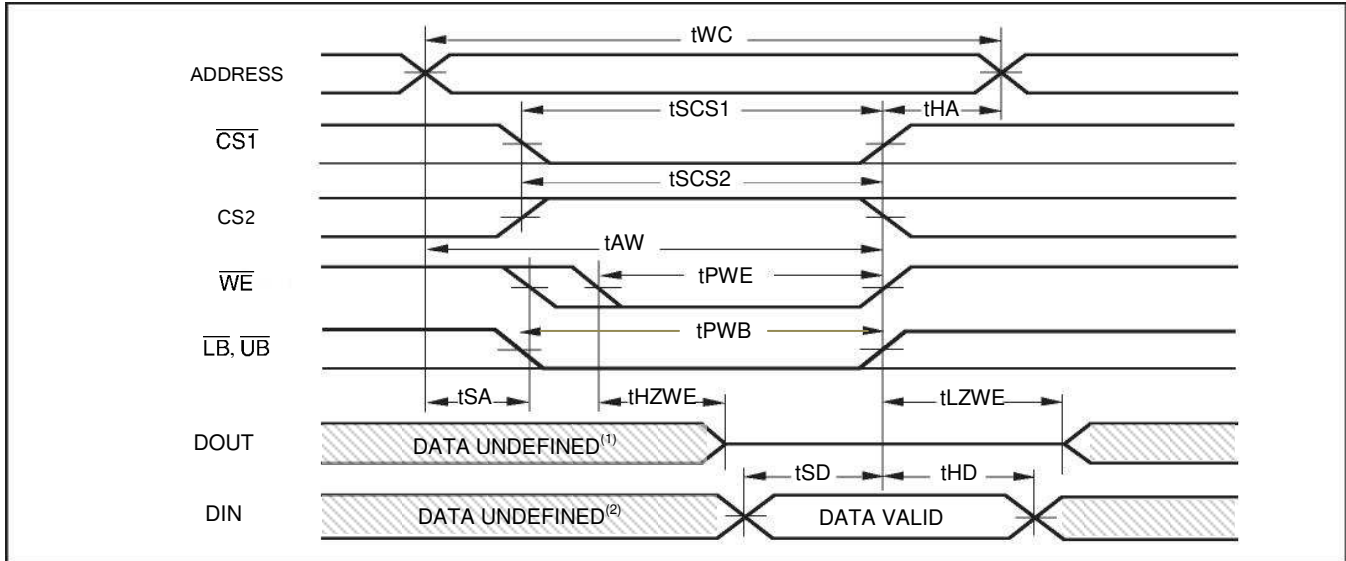

Notes:

1. tHZWE is based on the assumption when tSA=0nS after READ operation. Actual DOUT for tHZWE may not appear if  $\overline{OE}$  goes high before Write Cycle. tHZOE is the time DOUT goes to High-Z after  $\overline{OE}$  goes high.
2. During this period the I/Os are in output state. Do not apply input signals.

**WRITE CYCLE NO. 2 ( $\overline{WE}$  CONTROLLED:  $\overline{OE}$  IS HIGH DURING WRITE CYCLE)**

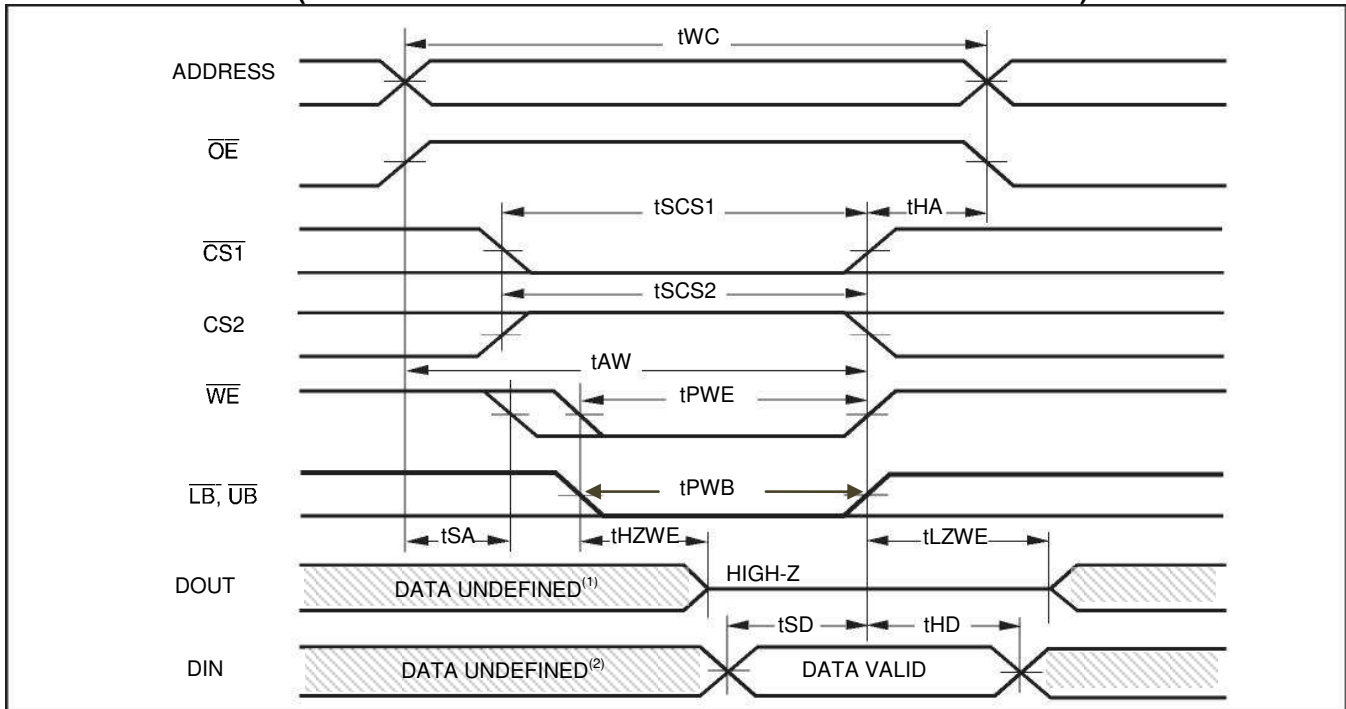

Notes:

1. tHZWE is based on the assumption when tSA=0nS after READ operation. Actual DOUT for tHZWE may not appear if  $\overline{OE}$  goes high before Write Cycle. tHZOE is the time DOUT goes to High-Z after  $\overline{OE}$  goes high.
2. During this period the I/Os are in output state. Do not apply input signals.

WRITE CYCLE NO. 3 ( $\overline{WE}$  CONTROLLED:  $\overline{OE}$  IS LOW DURING WRITE CYCLE)

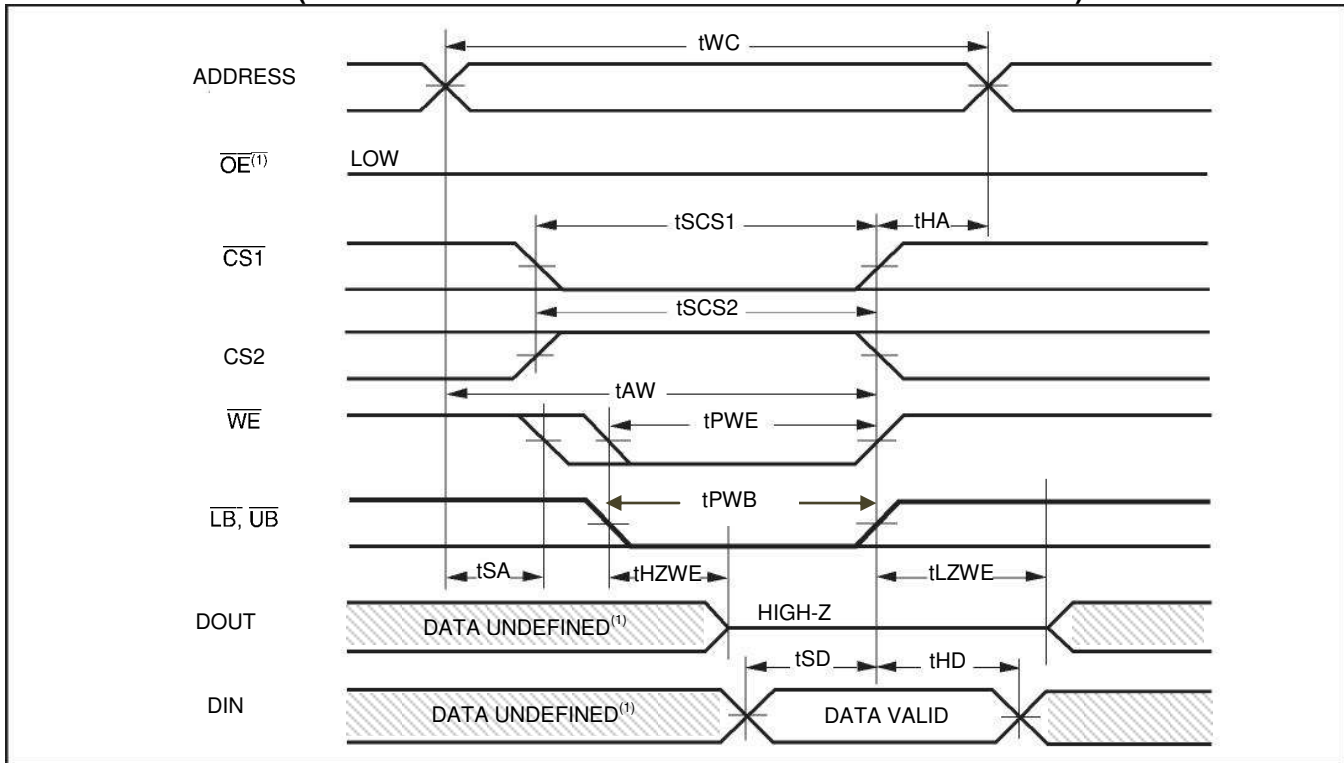

Notes:

1. If  $\overline{OE}$  is low during write cycle,  $t_{HZWE}$  must be met in the application. Do not apply input signal during this period. Data output from the previous READ operation will drive IO BUS.

WRITE CYCLE NO. 4 ( $\overline{UB}$  &  $\overline{LB}$  CONTROLLED)

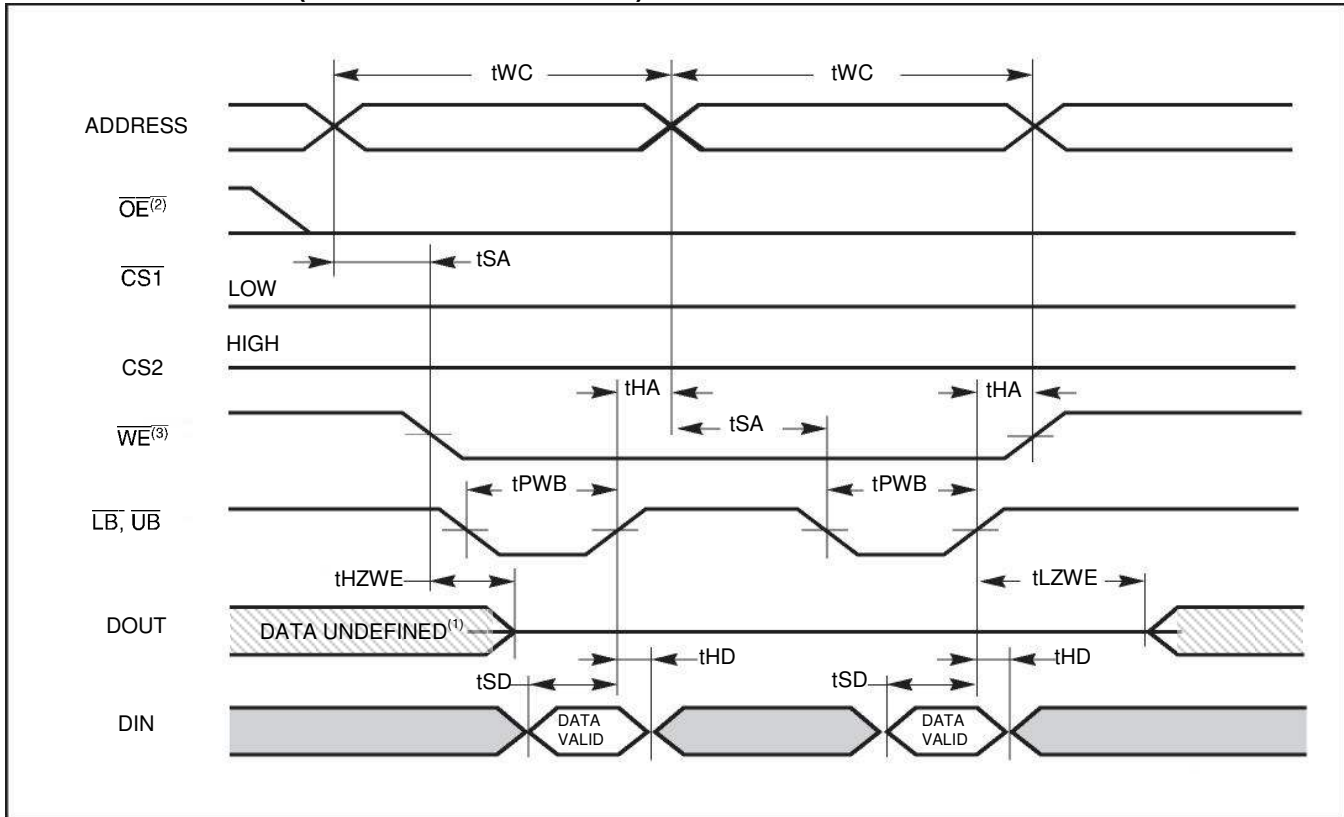

Notes:

1. If  $\overline{OE}$  is low during write cycle, tHZWE must be met in the application. Do not apply input signal during this period. Data output from the previous READ operation will drive IO BUS.
2. Due to the restriction of note 1,  $\overline{OE}$  is recommended to be HIGH during write period.
3. Note  $\overline{WE}$  stays LOW in this example. If  $\overline{WE}$  toggles, tPWE and tHZWE must be considered.

**DATA RETENTION CHARACTERISTICS**

Symbol	Parameter	Test Condition	OPTION	Min.	Typ. <sup>(2)</sup>	Max.	Unit
V <sub>DR</sub>	V <sub>DD</sub> for Data Retention	See Data Retention Waveform	IS62(5)WV51216EALL	1.5		-	V
			IS62(5)WV51216EBLL	1.5		-	V
I <sub>DR</sub>	Data Retention Current	V <sub>DD</sub> = V <sub>DR</sub> (min), (1) 0V ≤ CS2 ≤ 0.2V, or (2) $\overline{CS1} \geq V_{DD} - 0.2V$ , CS2 ≥ V <sub>DD</sub> - 0.2V (3) $\overline{LB}$ and $\overline{UB} \geq V_{DD} - 0.2V$ , $\overline{CS1} \leq 0.2V$ , CS2 ≥ V <sub>DD</sub> - 0.2V	Com.	-	-	20	uA
			Ind.	-	-	25	
			Auto	-	-	50	
t <sub>SDR</sub>	Data Retention Setup Time	See Data Retention Waveform		0	-	-	ns
t <sub>RDR</sub>	Recovery Time	See Data Retention Waveform		t <sub>RC</sub>	-	-	ns

Note:

1. If  $\overline{CS1} > V_{DD} - 0.2V$ , all other inputs including CS2 and  $\overline{UB}$  and  $\overline{LB}$  must meet this condition.
2. Typical values are measured at V<sub>DD</sub>=V<sub>DR</sub>(min), TA = 25°C and not 100% tested.

**DATA RETENTION WAVEFORM ( $\overline{CS1}$  CONTROLLED)**

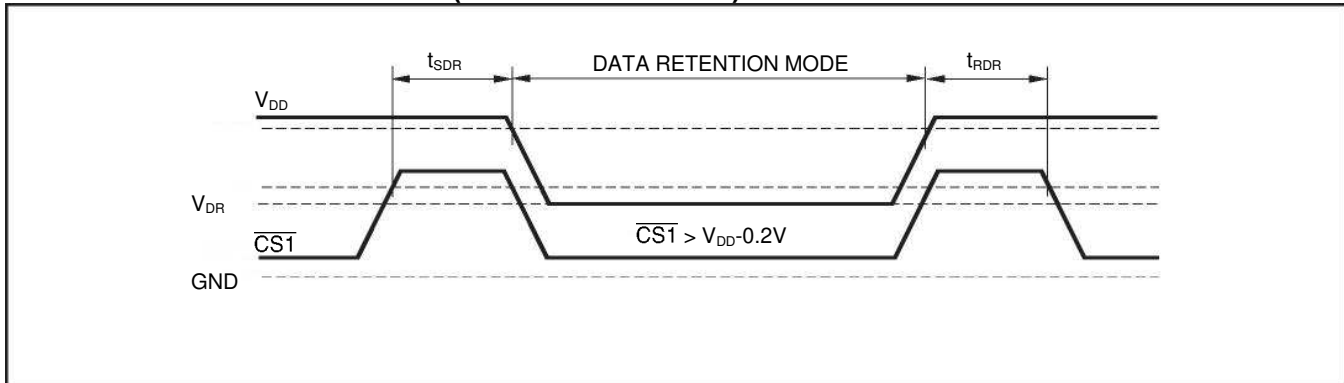

**DATA RETENTION WAVEFORM (CS2 CONTROLLED)**

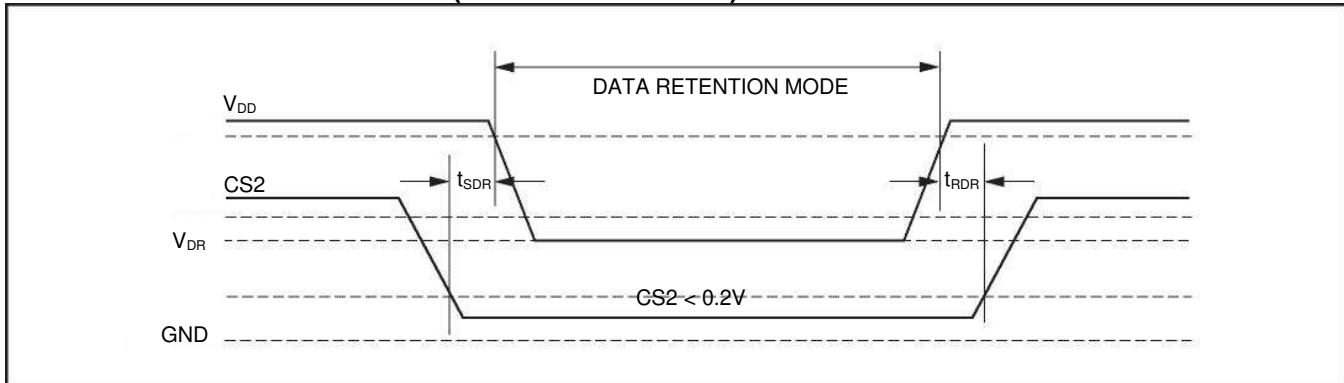

DATA RETENTION WAVEFORM ( $\overline{UB}$  AND  $\overline{LB}$  CONTROLLED)

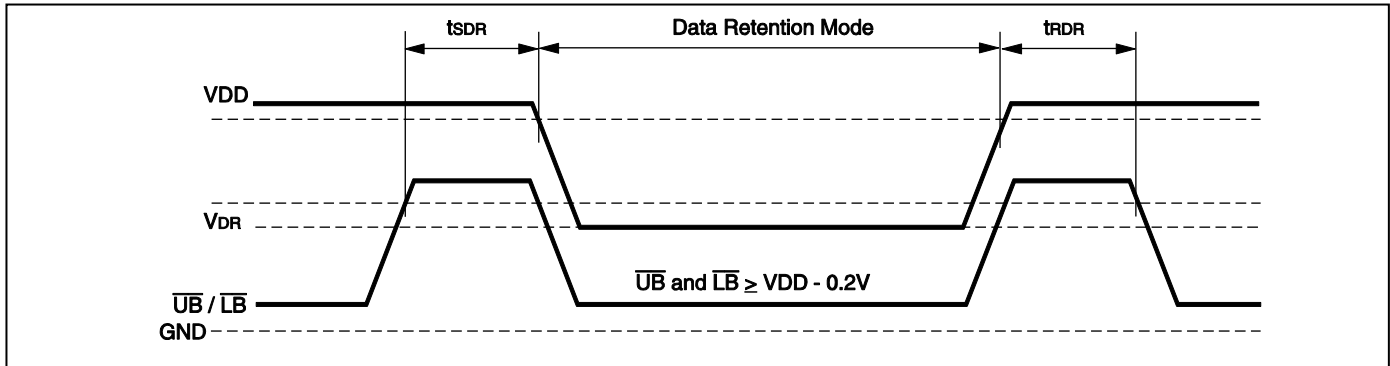

**Note:**

1.  $\overline{CS2}$  must satisfy either  $\overline{CS2} \geq V_{cc} - 0.2V$  or  $\overline{CS2} \leq 0.2V$
2.  $\overline{CS1}$  must satisfy either  $\overline{CS1} \geq V_{cc} - 0.2V$  or  $\overline{CS1} \leq 0.2V$

**ORDERING INFORMATION**

**IS62/65WV51216EALL (1.65V - 2.2V)**

**Industrial Range: -40°C to +85°C**

Speed (ns)	Order Part No.	Package
55	IS62WV51216EALL-55TI	TSOP-II
	IS62WV51216EALL-55TLI	TSOP-II, Lead-free
	IS62WV51216EALL-55BI	mini BGA
	IS62WV51216EALL-55BLI	mini BGA, Lead-free

**ORDERING INFORMATION**

**IS62/65WV51216EBLL (2.2V - 3.6V)**

**Industrial Range: -40°C to +85°C**

Speed (ns)	Order Part No.	Package
45	IS62WV51216EBLL-45TI	TSOP-II
	IS62WV51216EBLL-45TLI	TSOP-II, Lead-free
	IS62WV51216EBLL-45T2LI	2 CS option TSOP I, Lead-free
	IS62WV51216EBLL-45BI	mini BGA
	IS62WV51216EBLL-45BLI	mini BGA, Lead-free
55	IS62WV51216EBLL-55TI	TSOP-II
	IS62WV51216EBLL-55TLI	TSOP-II, Lead-free
	IS62WV51216EBLL-55BI	mini BGA
	IS62WV51216EBLL-55BLI	mini BGA, Lead-free

**Automotive Range A3: -40°C to +125°C**

Speed (ns)	Order Part No.	Package
45	IS65WV51216EBLL-45BA3	mini BGA
	IS65WV51216EBLL-45BLA3	mini BGA, Lead-free
	IS65WV51216EBLL-45CTA3	TSOP II, Copper Leadframe
	IS65WV51216EBLL-45CTLA3	TSOP II, Lead-free, Copper Leadframe

PACKAGE INFORMATION

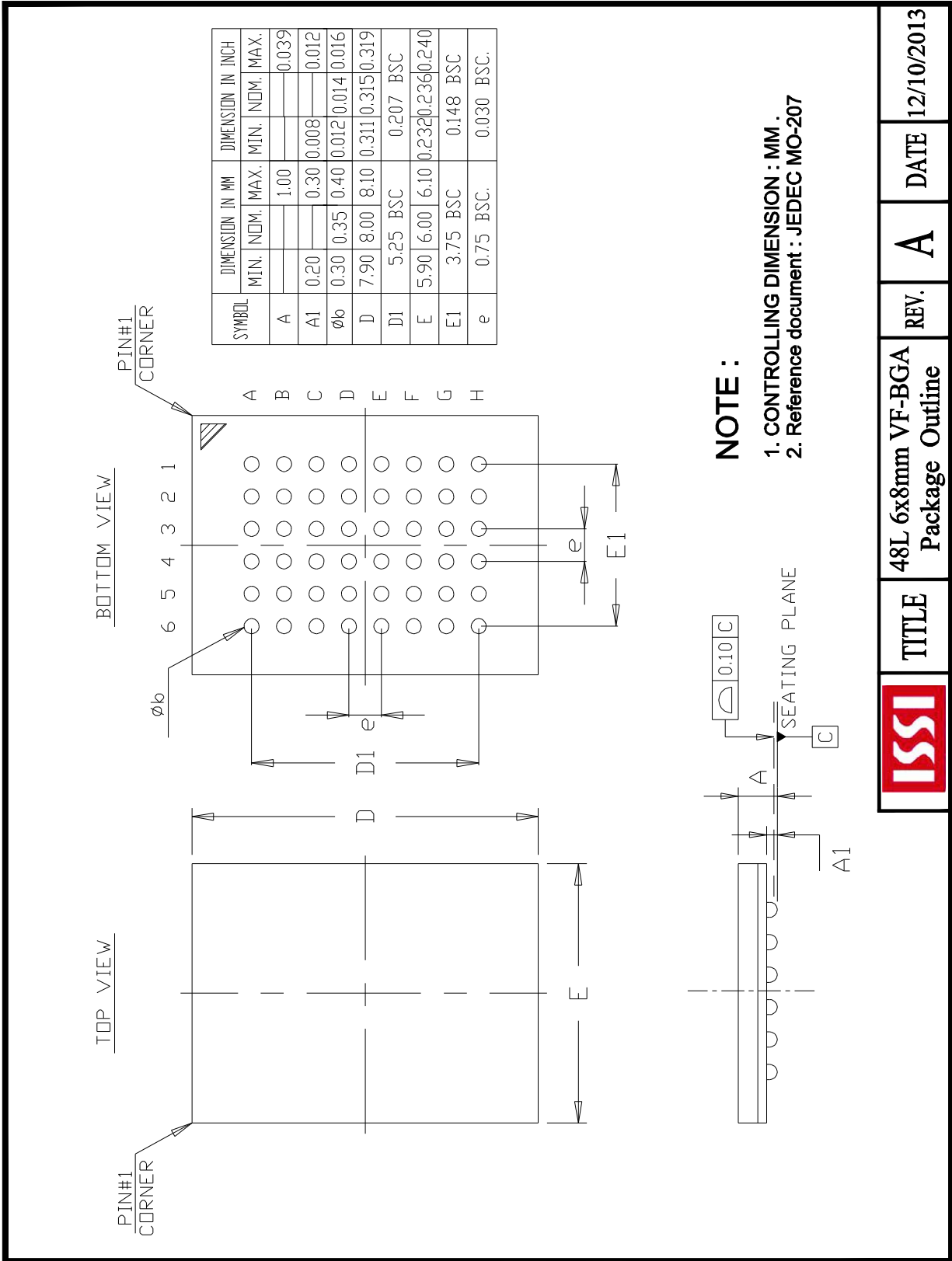

	TITLE	48L 6x8mm VF-BGA Package Outline	REV.	A	DATE	12/10/2013
--	-------	-------------------------------------	------	---	------	------------



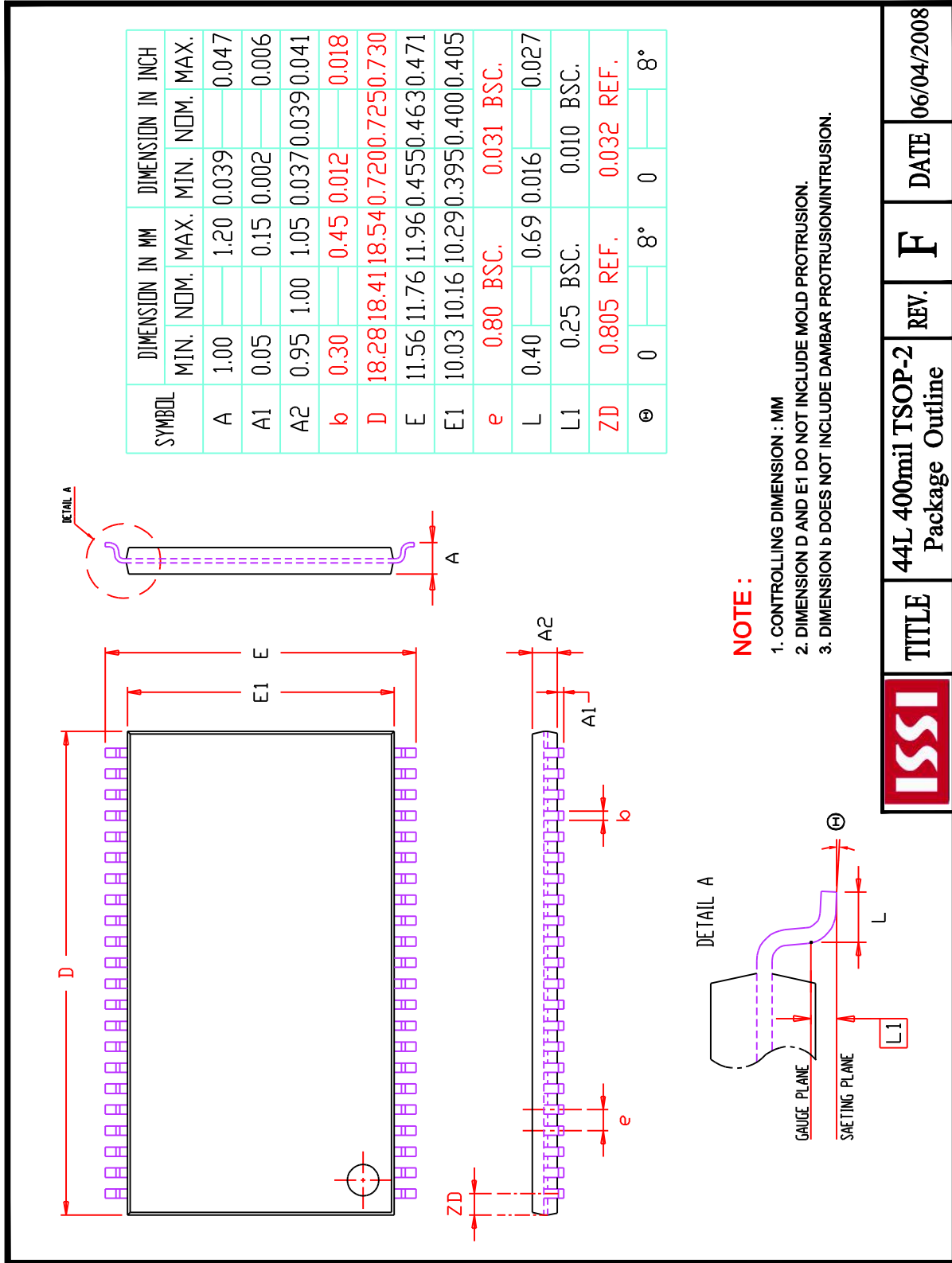

	<b>TITLE</b>	44L 400mil TSOP-2 Package Outline	<b>REV.</b>	<b>F</b>	<b>DATE</b>	06/04/2008
--	--------------	--------------------------------------	-------------	----------	-------------	------------

