

## User's Guide

# **M0116SY-161MSAR1-S2C**

## **VFD**-RoHS Compliant

(Vacuum Fluorescent Display Module)

\*with right angle shrouded connector

---

For product support, contact

Newhaven Display International  
2511 Technology Drive #101  
Elgin, IL 60124  
Tel: (847) 844-8795 Fax: (847) 844-8796

March 26, 2009

STANDARD NAME	SPECIFICATION FOR APPROVAL	DOCUMENT NO	REV. NO	PAGE
			00	2/10

## 1.0 INTRODUCTION

This module is an integrated display module utilizing the D0116SY-20-1601F single row 16 character alpha numeric VFD. An on board converter supplies the DC and AC voltages necessary to drive the VFD from a single 5V supply. Display driver circuitry provides character generation for 64 characters as well as 32 dimming levels. Control of the module is via a simple synchronous serial interface.

## 2.0 APPLICABLE DOCUMENTS

- 2.1 Engineering Standard Printed Circuit Board Layout criteria.
- 2.2 Vacuum Fluorescent Display Specification Number D0116SY-20-1601F.
- 2.3 Engineering Standard Printed Circuit Board Makings.

## 3.0 SPECIFICATIONS

### 3.1 GENERAL SPECIFICATIONS

Item	Value
Number of Characters	16, 1 row
Character Configuration	14 segment alphanumeric
Character Height	5.0mm
Character Width	3.0mm
Character Pitch	5.5mm
Character Tilt	5°
Peak Wavelength	Green(505nm)
Luminance	204 fL typ.

### 3.2 MECHANICAL DRAWING

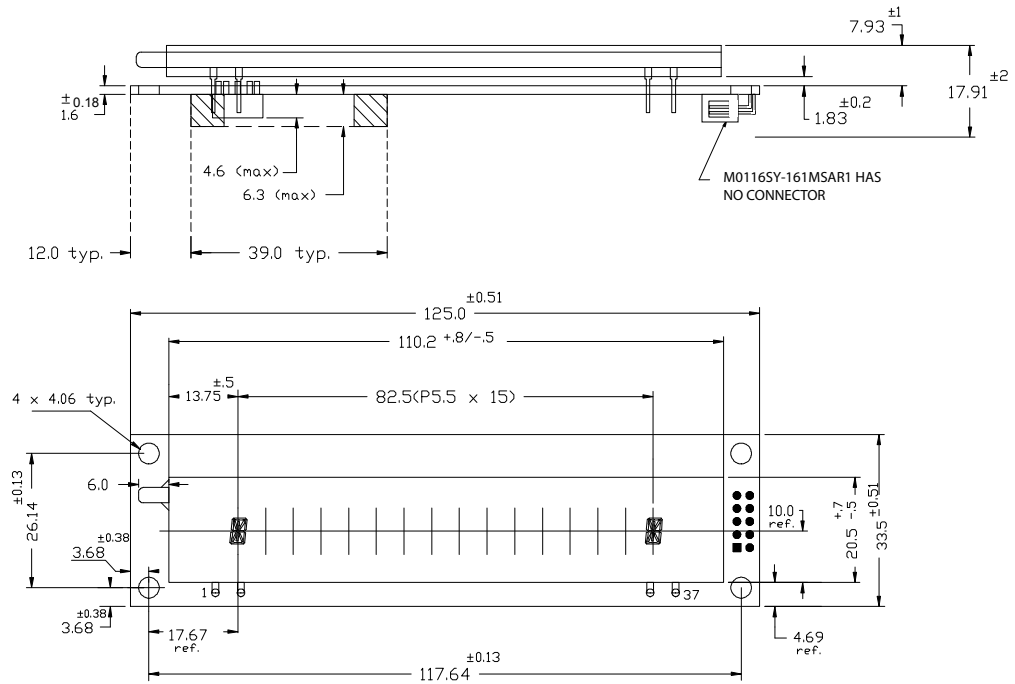

Figure 1. Mechanical Drawing (Not to scale)

NOTES: F: filament P: anode G: grid NC: No connection NP: No pin

### 3.3 SYSTEM BLOCK DIAGRAM

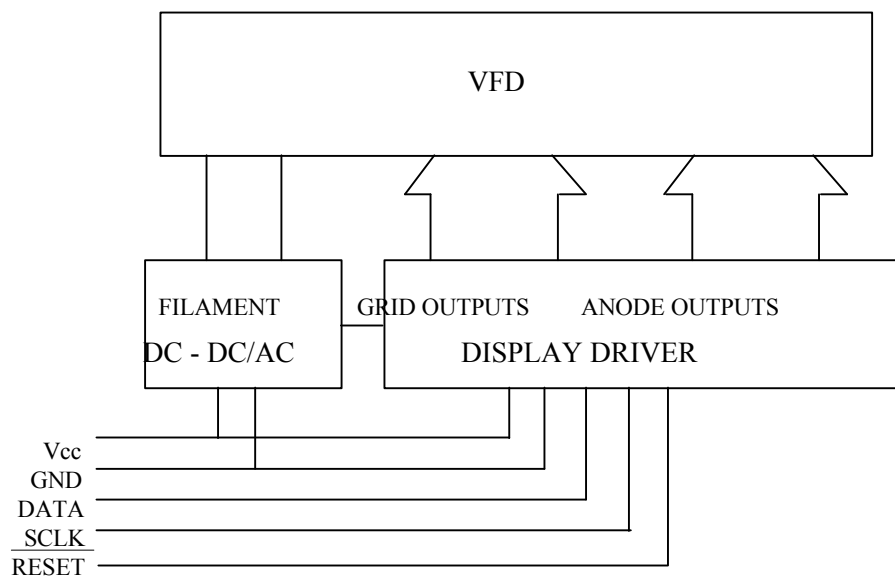

Figure 2. Block Diagram

STANDARD NAME	SPECIFICATION FOR APPROVAL	DOCUMENT NO	REV. NO	PAGE
			00	4/10

### 3.4 ENVIRONMENTAL SPECIFICATIONS

Item	Symbol	Min.	Max.	Unit
Operating Temperature	Topr	-40	+85	°C
Storage Temperature	Tstg	-50	+95	°C
Relative Humidity (Operating)	Hopr	0	85	%
Relative Humidity (Storage)	Hstg	0	90	%
Vibration (Note 1)			4	G
Shock (Note 2)			40	G

**Notes:**

1. Amplitude: 1.5mm; Frequency: 10-55 Hz; Sweep time: 1 min/cycle; Time: 2 hours/axis (x,y,z).
2. Duration: 11ms; half sine wave; 3 times each (x,y,z).

### 3.5 ABSOLUTE MAXIMUM ELECTRICAL RATINGS

Item	Symbol	Min.	Max.	Unit
Power Supply Voltage	Vcc	-0.3	+6.5	V
Input Signal voltage	Vin	-0.3	Vcc+0.3	V

### 3.6 DC ELECTRICAL CHARACTERISTICS

Item	Symbol	Min.	Typ.	Max.	Unit
Power Supply Voltage	Vcc	4.5	5.0	5.5	V
Power Supply Current	Icc		150	200	mA
High Level Input Voltage	Vih	3.6		Vcc+0.3	V
High Level Input Current (Vih=5V)	Iih			+10	uA
Low Level Input Voltage	Vil	0		1.0	V
Low Level Input Current (Vil=0V)	Iil			-0.4	mA

**Note:** A surge current of up to 2 times maximum input current can occur upon power up. The peak surge current amplitude and duration are dependent on the host power supply characteristics.

STANDARD NAME	SPECIFICATION FOR APPROVAL	DOCUMENT NO	REV. NO	PAGE
			00	5/10

### 3.7 AC ELECTRICAL CHARACTERISTICS

Item	Symbol	Min.	Max.	Unit
Clock time high	$T_{on}$	1.0	20.0	us
Clock time low	$T_{off}$	1.0		us
Data Setup Time	$T_{su}$	200		ns
Data Hold Time	$T_{hd}$	100		ns
Wait between Data words	$T_{wait}$	40		us
Byte to Byte Time	$T_{bb}$	120		us
Reset time	$T_{rst}$	100		us
Data ready	$T_{rdy}$	100		us

#### TIMING DIAGRAMS

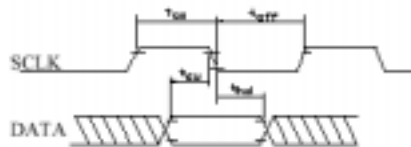

Figure 3. SCLK and DATA timing diagram

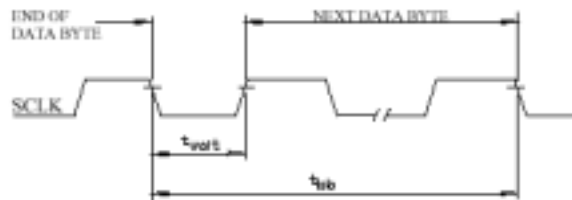

Figure 4. Byte to Byte timing

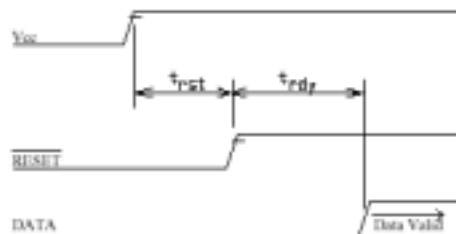

Figure 5. Power-up and Reset timing

STANDARD NAME	SPECIFICATION FOR APPROVAL	DOCUMENT NO	REV. NO	PAGE
			00	6/10

#### 4.0 FUNCTIONAL DESCRIPTION

Input data from the host system is loaded into the module's display buffer via the serial data input channel. The internal timing and control system synchronizes the signal and digit output signals to provide correct timing for the multiplexing operation. A 16 x 64 bit programmable logic array (PLA) is provided for segment decoding of the full upper-case ASCII character set. Input data from the host system is loaded as a series of 8-bit data bytes clocked in on the high to low transition of the clock.

##### Control and Character Data Bytes

The most significant bit (bit 7) is loaded first and is referred to as the control bit (C-bit). If the C-bit of any byte is logical 1, the byte is a control data byte; if it is logical 0, the byte is a character data byte. The functions and formats of control and character data bytes are described in detail below.

#### 4.1 WRITING CONTROL DATA BYTES

When the C-bit of the loaded byte is logical 1, it is recognized as a control data byte. See table below for the format and explanation of each.

8-BIT CONTROL BYTE 7 6 5 4 3 2 1 0	FUNCTION
1 0 1 0 X X X X	Load Buffer Pointer (position of character to be defined)
1 1 0 0 Y Y Y Y	Load Digit Counter (number of characters to be displayed)
1 1 1 Z Z Z Z Z	Load Duty Cycle (luminance level control)

- Notes:**
1. "XXXX" – 4 bit binary value of the digit position to be written to
  2. "YYYY" – 4 bit binary value of the number of characters to be displayed
  3. "ZZZZZ" – 5 bit binary value divided by 31 times 100% equals luminance level.

STANDARD NAME	SPECIFICATION FOR APPROVAL	DOCUMENT NO	REV. NO	PAGE
			00	7/10

#### 4.1.1 LOAD BUFFER POINTER

The buffer pointer control byte requires bits 7 to 4 to be set to 1010. This allows any specific character within the display to be modified. The character to be modified is represented by the value of bits 3 to 0. For a complete list of buffer pointer values see the table below.

Control Byte	AF	A0	A1	A2	A3	A4	A5	A6	A7	A8	A9	AA	AB	AC	AD	AE
Character Controlled	1	2	3	4	5	6	7	8	9	10	11	12	13	14	15	16

For example, to point to character position number 7, a hex value of A5 is entered; hence, the 8-bit byte would be:

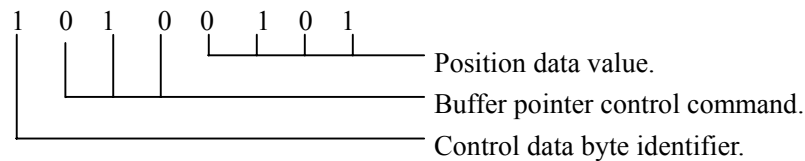

#### 4.1.2 LOAD DIGIT COUNTER

The digit counter control byte requires bits 7 to 4 to be set to 1100. This is used to define the number of character positions to be controlled. This byte is normally used only during initialization routines. The binary value of the data corresponding to bits 3 to 0 determines the actual number of characters to be controlled. If less than 16 characters are used, a number corresponding to the actual number of characters to be controlled should be entered.

For example, if six characters are to be controlled, a hex value of C6 is entered; hence, the 8-bit byte would be:

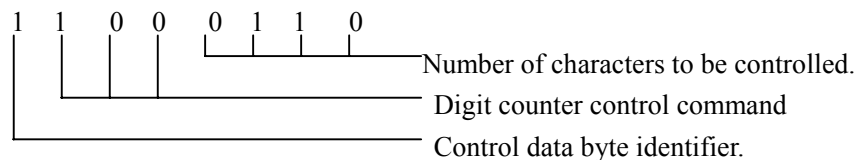

#### 4.1.3 LOAD DUTY CYCLE

The duty cycle control byte requires bits 7 to 5 to be set to 111. The value of the data corresponding to the remaining bits determines the luminance level of the display.

STANDARD NAME	SPECIFICATION FOR APPROVAL	DOCUMENT NO	REV. NO	PAGE
			00	8/10

The duty cycle control byte contains a five bit numeric field (bits 4 to 0) that allows the ‘on’ time for all digits to be modified. Luminance levels are available in 1/32 or 3.1% steps. A value of 31 represents maximum luminance, while a value of 0 places the output drivers into the “off” state and blanks the display.

For example, a binary value of 24 would force the display’s luminance level to be 77% of maximum luminance, and the full 8-bit byte would be:

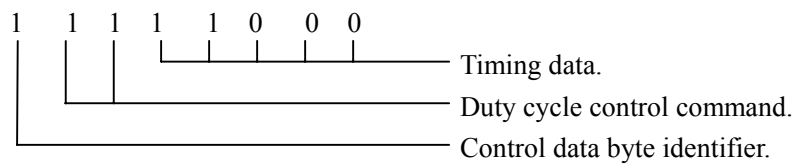

**4.2 WRITING CHARACTER DATA BYTES**

8-BIT DATA BYTE	FUNCTION
0 X Z Z Z Z Z Z	Character Data Byte

- NOTES:** 1. “X” - don’t care  
 2. “ZZZZZZ” - 6 bit character address from the character table

Character data bytes are loaded into the data buffer as 8 bit bytes, with the C-bit (bit 7) set to 0. The 64 available data bytes are shown in Figure 6, with their corresponding ASCII characters.

The display buffer pointer is automatically incremented before each character data byte is stored. Decimal points and commas will not cause the buffer pointer to increment, and are therefore always associated with the character data byte previously entered. If it is desirable to place characters out of sequence, that is not from position 1 to 16, then each character data byte must be preceded by the appropriate positional data through the use of the buffer pointer control byte.

**4.3 POWER-ON RESET**

Once Vcc has stabilized after power up, a 100us active low pulse must be applied to the RESET\ input to initialize the module. The following conditions are established after a RESET\ pulse has been applied.



STANDARD NAME	SPECIFICATION FOR APPROVAL	DOCUMENT NO	REV. NO	PAGE
			00	9/10

- 1) The duty cycle is set to 0 (this blanks the display).
- 2) The digit counter is set to 16 characters.
- 3) The buffer pointer is set to point to the left most character (position 1).

## 5.0 INTERFACE CONNECTIONS

The M0116SY-161MSA1 version of this module has a 10 pin dual row unshrouded header (DuPont P/N 67996-110).

Pin	Function	Pin	Function
1	Vcc	2	GND
3	SCLK	4	GND
5	DATA	6	GND
7	Reset\	8	GND
9	NC	10	GND

STANDARD NAME	SPECIFICATION FOR APPROVAL	DOCUMENT NO	REV. NO	PAGE
			00	10/10

Figure 6. Character Codes

MSD LSD	0X000	0X001	0X010	0X011	0X100	0X101	0X110	0X111
000	0	1	2	3	4	5	6	7
001	8	9	0	1	2	3	4	5
010	6	7	8	9	0	1	2	3
011	4	5	6	7	8	9	0	1
100	2	3	4	5	6	7	8	9
101	0	1	2	3	4	5	6	7
110	8	9	0	1	2	3	4	5
111	6	7	8	9	0	1	2	3