

E-Stop Smart Box (part no. 73-00002.2)

Technical specifications

Description

Emergency stop Smart Box wired to 8 pin M12 plug with red illuminated 2NC emergency stop switch. The housing and switch are sealed to IP65 when assembled and connected to a suitable M12 cable

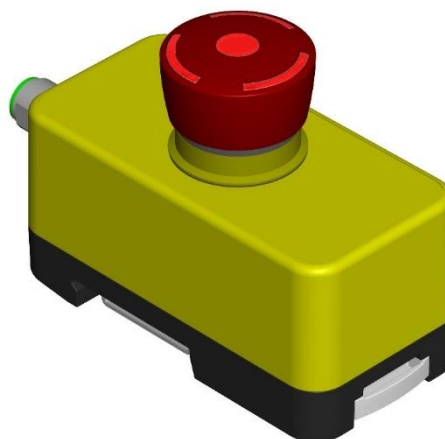

Shipped:

- with mounting adapter
- with red illuminated emergency stop switch internally wired to 8-pin M12 plug

Equipment

Connection:

M12 8-pin plug, male, A-coding

Control element:

Series 84 emergency stop switch / fully illuminated / part no. 84-5141.2B20

Connector pin assignment

Pin 1:	(Unused)
Pin 2:	Contact 'a'
Pin 3:	LED negative terminal
Pin 4:	Contact 'a'
Pin 5:	(Unused)
Pin 6:	Contact 'b'
Pin 7:	Contact 'b'
Pin 8:	LED positive terminal

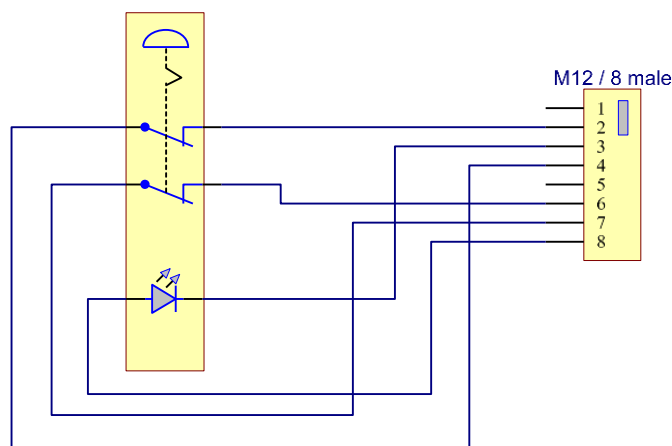

Electrical characteristics

Button operating voltage:

Maximum 30VDC

Switching rate:

Maximum 2A / contact

LED operating voltage

5VDC ... 30VDC

For further technical data regarding the emergency stop switch, please refer to the EAO data sheet 84-5141.2B20.

Mechanical characteristics

External dimensions:

See dimensional diagram 1
(Female M12 connector not included)

Note:

- The dimensional diagram shows the housing with the emergency stop switch and M12 plug installed
- All side walls exhibit a pull of around 1°.

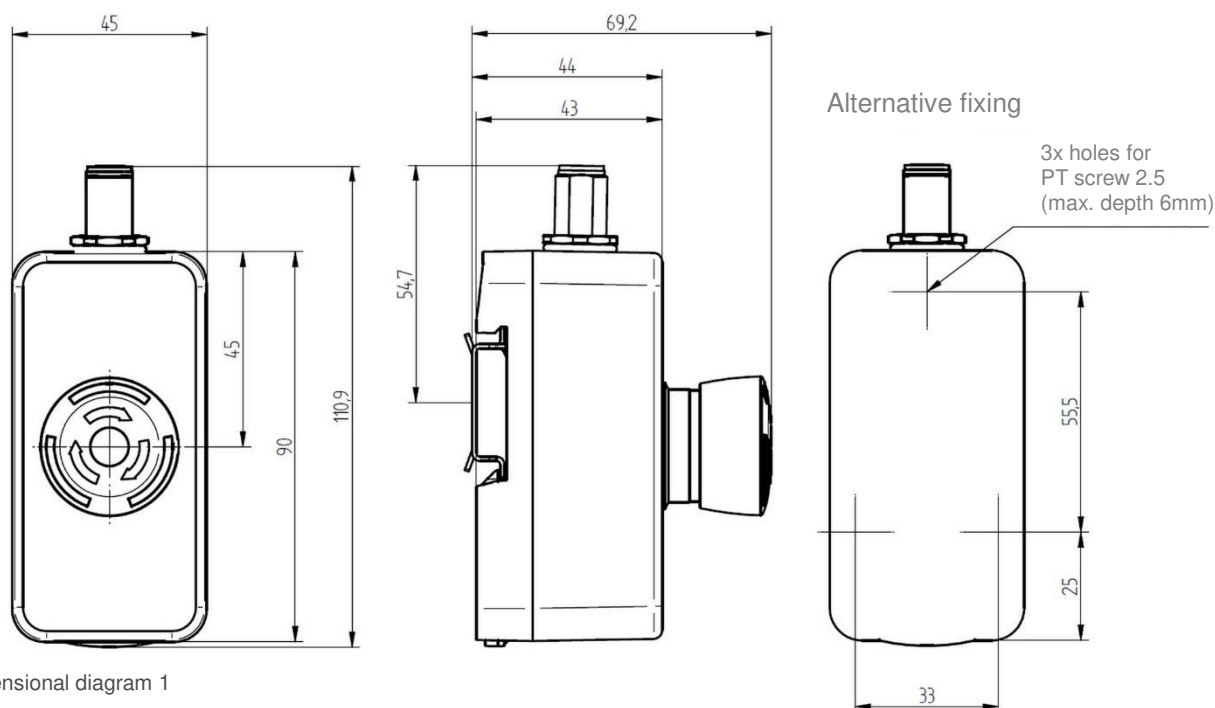

Dimensional diagram 1

Mounting

- Mount mounting adapter onto mounting surface
- Mount emergency stop Smart Box on one side (note direction of mounting adapter on the housing)
- Push the Smart Box onto the adaptor on the other side until it audibly clicks into place
- Alternatively, the module can be mounted on a standard top hat rail, or it can be mounted on a base using screws on the rear (see dimensional diagrams).

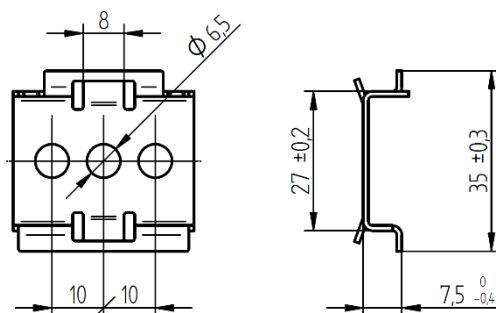

Dismantling

- Pull out spring element using screwdriver and lift Smart Box
- Remove Smart Box from the other side

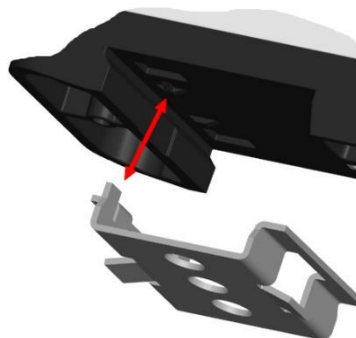

Operating temperatures

Temperature range:	Rated temperature:	25°C
	Operating temperature:	-25 ... 60°C
	Storage temperature:	-25 ... 80°C

Materials

Upper part of housing:	PBT / UL-V0 / colour similar to RAL1004
Lower part of housing:	PBT / UL-V0 / colour similar to RAL9011
Spring element (for restraint):	POM (nature)
Seal:	MVQ silicone foam bright
Mounting adaptor:	Stainless steel 1.4301 / surface vibratory finish
Housing screws:	Stainless steel A2
M12 connector housing:	Die cast zinc

Standards

Degree of protection:	IP65 (with mounted female connector and emergency stop switch)
Insulation:	EN 60664-1:2008 / degree of contamination I / insulation material IIIa/b
EMC:	Defined based on components of EAO Series 84
Vibrations:	EN 60068-2-6:2008-10 / 10 – 150Hz / 2g
Shock:	EN 60068-2-27:2010-02 / 15g / 11ms
Approvals (emergency stop switch only)	EN 60947-5-1 / EN 60947-5-5 / EN 13850 / EN 60204
Approvals (emergency stop switch only)	UL / CB IEC 60947
Conformity	CE

EAO reference number: **Part no. 73-00002.2**

EAO reserves the right to change specifications without further notice.