

N= NUMBER OF CONCATS

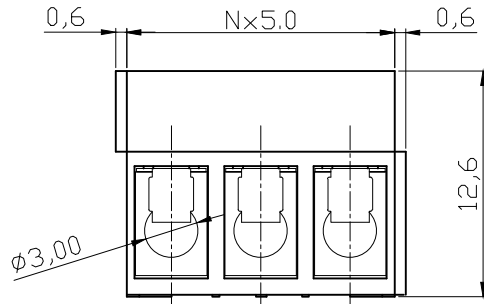

P.C.B LAYOUT

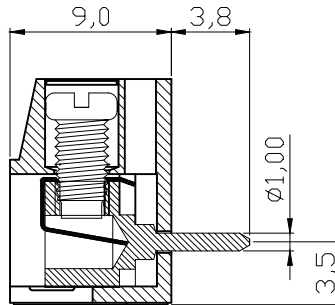
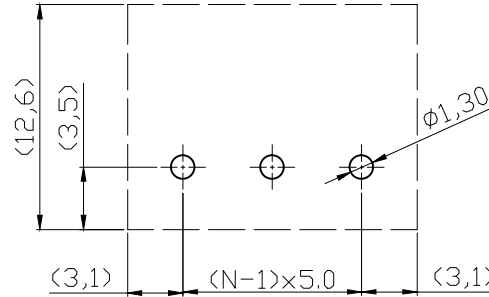

Material

- 1.Terminal body  
(metal housing): Brass(CuZn)
- 2.Terminal screw:Steel Zinc plating"-slot type
- 3.Wire guard:Stainless steel
- 4.Surface of solder tail:Tin plated
- 5.Insulator (housing): Thermoplastic (UL94V-0),Blue

Electrical UL/CSA

- 1.Voltage rating: 250VAC/250VAC
- 2.Current rating: 16A/16A
- 3.Wire range:
- 4.Solid wire(AWG): 14/14-22
- 5.Stranded wire(AWG): 14-22
- 6.Torque: 2.6Lb-In/4Kgf.cm
- 7.Screw:M3
- 8.Wire strip length:6-7mm
- 9.Withstanding Voltage: 1.5KV/1.5KV
- 10.Operating temperature: -40°C to +115°C
- 11.Soldering temperature: 250°C±10°C/5 Sec
- 12.Safety Approval:

**RoHS compliant**

Unit: mm



File No.: E349947

Scale	1:1					Date	Name	Customer-No.
TOLERANCE					Drawn	29.07.2009	Dean	
X.	±0.50				Approved	18.04.2016	Joanna	ASSMANN WSW-No.
X.X	±0.30							<b>A-TB500-TBxx</b>
X.XX	±0.10							Drawing-No.
DIM	TOL	②	Add UL	18.04.2016	Joanna	<b>ASSMANN</b> WSW components		
X.°	±1°	①	Drawn	29.07.2009	Dean			
X.X°	±X°							Replace
Angle	TOL	Id.	Modification	Date	Name			Sheet