

LOC		DIST		REVISIONS			
F	LTR	PER	ECO	DATE	DN	APVD	
LS	REVISED	PER	ECO-13-015097	25SEP2013	KH	JO	

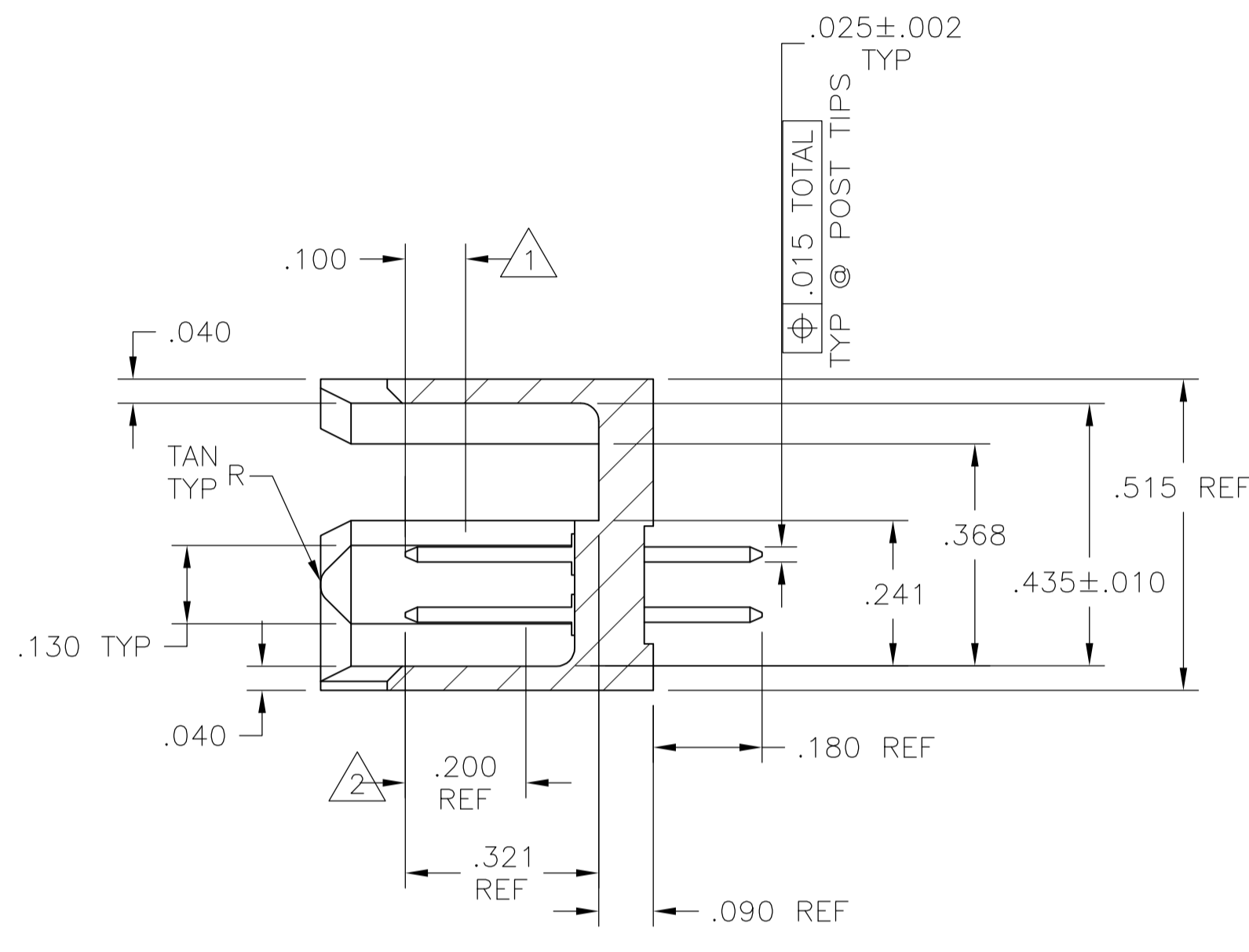

SECTION X-X

- 1 POINT OF MEASUREMENT FOR PLATING THICKNESS.
- 2 FINISH OVER INDICATED AREA: .000030 GOLD OVER .000050 NICKEL.
- 3 FINISH OVER INDICATED AREA: .000100-.000200 BRIGHT TIN LEAD OVER .000050 NICKEL.
- 4 RECESSED DATE CODE AND LOGO.
- 5 OBSOLETE PART NUMBER.
- 6 PRELIMINARY PART - NOT RELEASED FOR PRODUCTION
- 7 FINISH OVER INDICATED AREA: .000100-.000200 MATTE TIN OVER .000050 NICKEL.
- 8 ROHS 2002/95/EC COMPLIANT
- 9 OBSOLETE PARTS: OBSOLETE CIS STREAMLINING PER D.RENAUD/D.SINISI

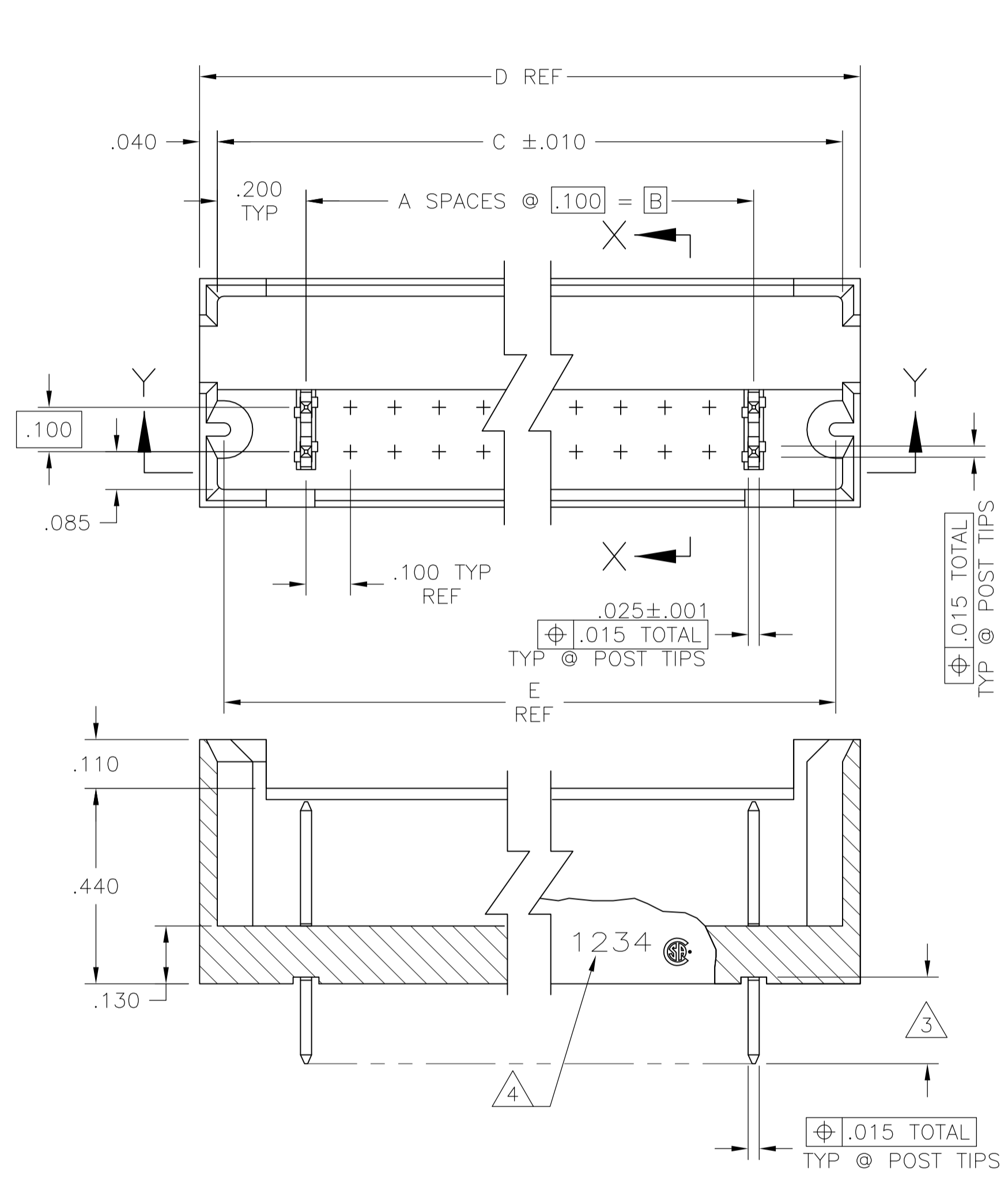
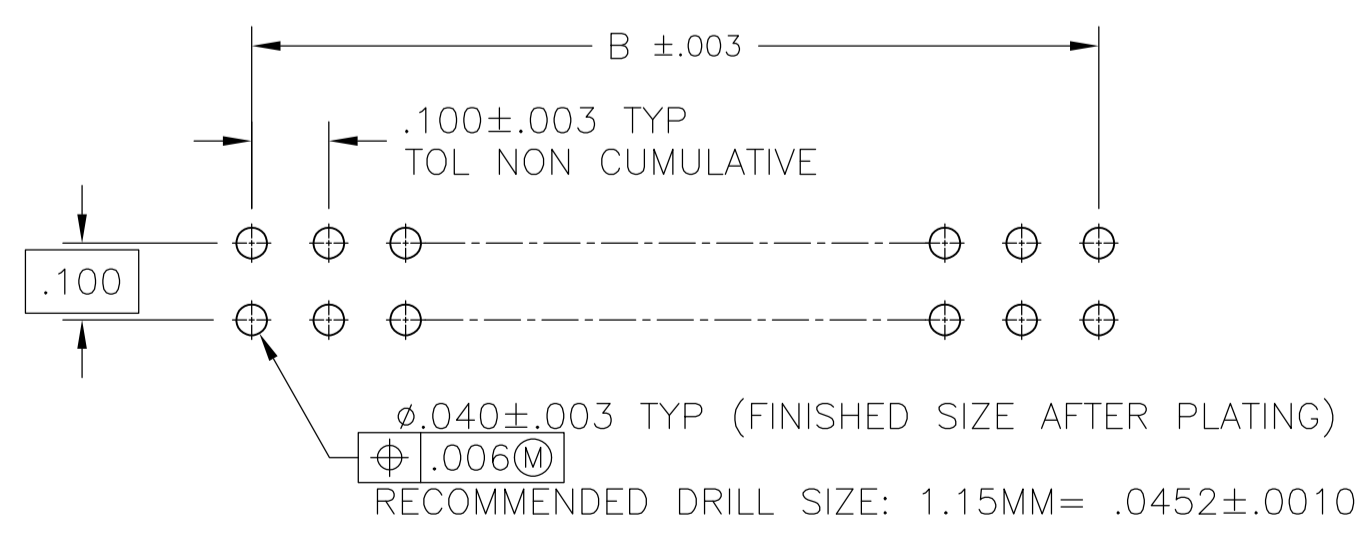

RECOMMENDED HOLE SIZE

NO. OF POSN	A	B	C ± .010	D	E	PART NUMBER
12	26	12	1.600	1.200	1.570	7-102692-9
79	160	79	8.300	7.900	8.270	7-102692-8
46	94	46	5.000	4.600	4.970	7-102692-7
21	44	21	2.500	2.100	2.470	7-102692-6
6	14	6	1.000	.600	.970	7-102692-5
89	180	89	9.300	8.900	9.270	7-102692-4
73	148	73	7.700	7.300	7.670	7-102692-3
63	128	63	6.700	6.300	6.670	7-102692-2
69	140	69	7.300	6.900	7.270	7-102692-1
64	130	64	6.800	6.400	6.770	7-102692-0
42	86	42	4.600	4.200	4.570	6-102692-9
35	72	35	3.900	3.500	3.870	6-102692-8
14	30	14	1.800	1.400	1.770	6-102692-7
9	20	9	1.300	.900	1.270	6-102692-6
7	16	7	1.100	.700	1.070	6-102692-5
34	70	34	3.800	3.400	3.770	6-102692-4
19	40	19	2.300	1.900	2.270	6-102692-3
44	90	44	4.800	4.400	4.770	6-102692-2
99	200	99	10.300	9.900	10.270	6-102692-1
54	110	54	5.800	5.400	5.770	6-102692-0
59	120	59	6.300	5.900	6.270	5-102692-9
49	100	49	5.300	4.900	5.270	5-102692-8
47	96	47	5.100	4.700	5.070	5-102692-7
39	80	39	4.300	3.900	4.270	5-102692-6
29	60	29	3.300	2.900	3.270	5-102692-5
24	50	24	2.800	2.400	2.770	5-102692-4
17	36	17	2.100	1.700	2.070	5-102692-3
11	24	11	1.500	1.100	1.470	5-102692-2
5	12	5	.900	.500	.870	5-102692-1
12	26	12	1.600	1.200	1.570	2-102692-9
79	160	79	8.300	7.900	8.270	2-102692-8
46	94	46	5.000	4.600	4.970	2-102692-7
21	44	21	2.500	2.100	2.470	2-102692-6
6	14	6	1.000	.600	.970	2-102692-5
89	180	89	9.300	8.900	9.270	2-102692-4
73	148	73	7.700	7.300	7.670	2-102692-3
63	128	63	6.700	6.300	6.670	2-102692-2
69	140	69	7.300	6.900	7.270	2-102692-1
64	130	64	6.800	6.400	6.770	2-102692-0
42	86	42	4.600	4.200	4.570	1-102692-9
35	72	35	3.900	3.500	3.870	1-102692-8
14	30	14	1.800	1.400	1.770	1-102692-7
9	20	9	1.300	.900	1.270	1-102692-6
7	16	7	1.100	.700	1.070	1-102692-5
34	70	34	3.800	3.400	3.770	1-102692-4
19	40	19	2.300	1.900	2.270	1-102692-3
44	90	44	4.800	4.400	4.770	1-102692-2
99	200	99	10.300	9.900	10.270	1-102692-1
54	110	54	5.800	5.400	5.770	1-102692-0
59	120	59	6.300	5.900	6.270	102692-9
49	100	49	5.300	4.900	5.270	102692-8
47	96	47	5.100	4.700	5.070	102692-7
39	80	39	4.300	3.900	4.270	102692-6
29	60	29	3.300	2.900	3.270	102692-5
24	50	24	2.800	2.400	2.770	102692-4
17	36	17	2.100	1.700	2.070	102692-3
11	24	11	1.500	1.100	1.470	102692-2
5	12	5	.900	.500	.870	102692-1

THIS DRAWING IS A CONTROLLED DOCUMENT.

DIMENSIONS: INCHES
 TOLERANCES UNLESS OTHERWISE SPECIFIED:
 0 PLC ± -
 1 PLC ± -
 2 PLC ± -
 3 PLC ± .005
 4 PLC ± -
 ANGLES ± -

MATERIAL: HEADERS: GLASS FILLED FLAME RETARDANT THERMOPLASTIC COLOR-BLACK POST: COPPER ALLOY
 FINISH: SEE TABLE

DWG: B. HAYMAKER 11JAN01
 CHK: J. GESFORD 12NOV98
 APVD: J. GESFORD 12NOV98
 NAME: NAME
 PRODUCT SPEC: PRODUCT SPEC
 APPLICATION SPEC: APPLICATION SPEC

SIZE: A1
 CAGE CODE: 00779
 DRAWING NO: 102692
 WEIGHT: -
 CUSTOMER DRAWING

RESTRICTED TO: -
 SCALE: 4:1
 SHEET: 1 of 1
 REV: L5

STE TE Connectivity
 HEADER ASSEMBLY, MOD II, .100C.100CL, .025 SQ POSTS