



ON Semiconductor®

<http://onsemi.com>

# LA1787M

## Monolithic Linear IC Single-Chip Tuner IC for Car Radios

### Overview

The LA1787M integrates all six blocks required in a car radio tuner on a single chip.

### Functions

- FM front end
- FM IF
- Noise canceller
- Multiple
- AM up-conversion
- FM/AM switch
- MRC

### Features

- Improved noise reduction methods
  - The FM front end provides excellent 3-signal characteristics equivalent to those of the LA1193M.
  - Superlative listenability due to improved medium and weak field noise canceller characteristics.
  - Improved separation characteristics
  - Anti-birdie filter
  - Improved AM and FM thermal characteristics
  - Excellent FM signal meter linearity
  - Modified N.C. circuit for improved noise rejection
- Improved AM adjacent channel interference characteristics ( $\Delta 40$  kHz)
- Double conversion AM tuner (up conversion) Reduces the number of external components required as compared to earlier double conversion tuners, in particular, no crystal is required (when used in conjunction with the LC72144).
- Sample-to-sample variation reduction circuit built into the FM IF circuit.  
(Fixed resistors are used for the SD, keyed AGC, mute on adjustment, ATT, SNC, and HCC functions.)
- Improved FM separation temperature characteristics
- The LA1787 inherits the block arrangement of the LA1780M and supports pin-compatible designs.

### Package Dimensions

unit : mm (typ)

QIP64E(14X14)

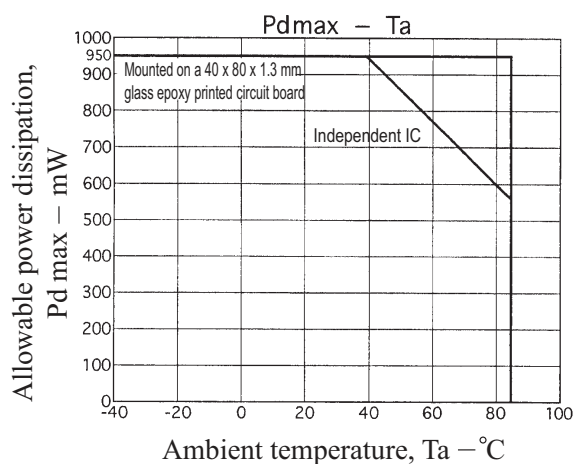
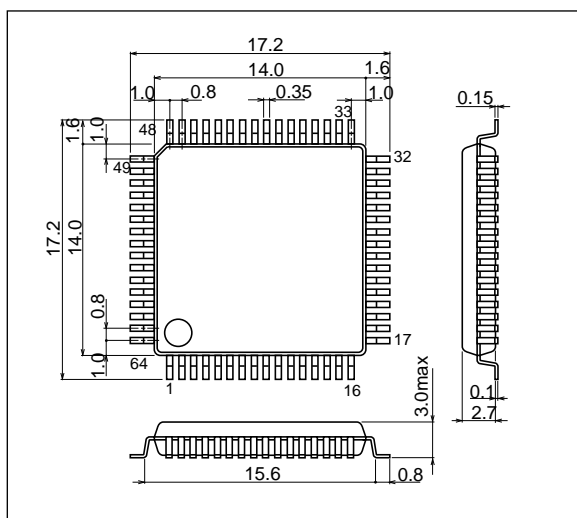

## Specifications

### Maximum Ratings at Ta = 25°C

Parameter	Symbol	Conditions	Ratings	Unit
Maximum supply voltage	V <sub>CC1</sub> max	Pins 6, 40, and 61	9	V
	V <sub>CC2</sub> max	Pins 7, 45, 54, 59, and 60	12	V
Allowable power dissipation	Pd max	Ta ≤ 55°C	950	mW
Operating temperature	Topr		-40 to +85	°C
Storage temperature	Tstg		-40 to +150	°C

### Operating Conditions at Ta = 25°C

Parameter	Symbol	Conditions	Ratings	Unit
Recommended supply voltage	V <sub>CC</sub>	Pins 6, 7, 40, 45, 54, 59, 60, and 61	8	V
	V <sub>CCST</sub> IND	Pin 26	5	V
Operating supply voltage range	V <sub>CC</sub> op		7.5 to 9.0	V

### Operating Characteristics at Ta = 25°C, V<sub>CC</sub> = 8.0V, in the specified test circuit for the FM IF input

Parameter	Symbol	Conditions	Ratings			unit
			min	typ	max	
[FM Characteristics] At the FM IF input						
Current drain	I <sub>CCO-FM</sub>	No input, I40 + I45 + I54 + I59 + I60 + I61	60	94	110	mA
Demodulation output	V <sub>O-FM</sub>	10.7 MHz, 100dBμ, 1 kHz, 100%mod, The pin 15 output	205	310	415	mVrms
Pin 31 demodulation output	V <sub>O-FM31</sub>	10.7 MHz, 100dBμ, 1 kHz, 100%mod, The pin 31 output	190	295	380	mVrms
Channel balance	CB	The ratio between pins 15 and 16 at 10.7 MHz, 100 dBμ, 1 kHz	-1	0	+1	dB
Total harmonic distortion	THD-FM mono	10.7 MHz, 100 dBμ, 1 kHz, 100% mod, pin 15		0.3	1	%
Signal-to-noise ratio: IF	S/N-FM IF	10.7 MHz, 100 dBμ, 1 kHz, 100% mod, pin 15	75	82		dB
AM suppression ratio: IF	AMR IF	10.7 MHz, 100 dBμ, 1 kHz, f <sub>m</sub> = 1 kHz, 30% AM, pin 15	55	68		dB
Muting attenuation	Att-1	10.7 MHz, 100 dBμ, 1 kHz. The pin 15 attenuation when V33 goes from 0 to 2 V	5	10	15	dB
	Att-2	10.7 MHz, 100 dBμ, 1 kHz. The pin 15 attenuation when V33 goes from 0 to 2 V*1	15	20	25	dB
	Att-3	10.7 MHz, 100 dBμ, 1 kHz. The pin 15 attenuation when V33 goes from 0 to 2 V*2	28	33	38	dB
Separation	Separation	10.7 MHz, 100 dBμ, L+R = 90%, pilot = 10%. The pin 15 output ratio	30	40		dB
Stereo on level	ST-ON	The pilot modulation such that V26 < 0.5 V	1.2	2.4	4.4	%
Stereo off level	ST-OFF	The pilot modulation such that V26 > 3.5 V	0.6	1.6		%
Main total harmonic distortion	THD-Main L	10.7 MHz, 100 dBμ, L+R = 90%, pilot = 10%. The pin 15 signal		0.3	1.2	%
Pilot cancellation	PCAN	10.7 MHz, 100 dBμ, pilot = 10%. The pin 15 signal/the pilot level leakage. DIN audio	20	30		dB
SNC output attenuation	AttSNC	10.7 MHz, 100 dBμ, L-R = 90%, pilot = 10%. V28 = 3 V → 0.6 V, pin 15	1	5	9	dB
HCC output attenuation	AttHCC-1	10.7 MHz, 100 dBμ, 10 kHz, L+R = 90%, pilot = 10%. V29 = 3 V → 0.6 V, pin 15	0.5	4.5	8.5	dB
	AttHCC-2	10.7 MHz, 100 dBμ, 10 kHz, L+R = 90%, pilot = 10%. V29 = 3 V → 0.1 V, pin 15	6	10	14	dB
Input limiting voltage	Vi-lim	100 dBμ, 10.7 MHz, 30% modulation. The IF input such that the input reference output goes down by 3 dB	33	40	47	dBμ
Muting sensitivity	Vi-mute	The IF input level (unmodulated) when V33 = 2 V	27	35	43	dBμ
SD sensitivity	SD-sen1 FM	The IF input level (unmodulated) (over 100 mV rms) such that the IF counter buffer output goes on	54	62	70	dBμ
	SD-sen2 FM		54	62	70	dBμ
IF counter buffer output	V <sub>IFBUFF-FM</sub>	10.7 MHz, 100 dBμ, unmodulated. The pin 23 output	130	200	270	mVrms
Signal meter output	V <sub>SM</sub> FM-1	No input. The pin 24 DC output, unmodulated	0.0	0.1	0.3	V
	V <sub>SM</sub> FM-2	50 dBμ. The pin 24 DC output, unmodulated	0.4	1.0	1.5	V
	V <sub>SM</sub> FM-3	70 dBμ. The pin 24 DC output, unmodulated	2.0	2.7	3.5	V
	V <sub>SM</sub> FM-4	100 dBμ. The pin 24 DC output, unmodulated	4.7	5.5	6.2	V
Muting bandwidth	BW-mute	100 dBμ. The bandwidth when V33 = 2 V, unmodulated	150	220	290	kHz
Mute drive output	V <sub>MUTE-100</sub>	100 dBμ, 0 dBμ. The pin 33 DC output, unmodulated	0.00	0.03	0.20	V

Continued on next page.

## LA1787M

Continued from preceding page.

Parameter	Symbol	Conditions	Ratings			unit
			min	typ	max	
[FM FE Mixer Input]						
N-AGC on input	V <sub>N-AGC</sub>	83 MHz, unmodulated. The input such that the pin 2 voltage is 2.0 V or below	81	88	95	dB $\mu$
W-AGC on input	V <sub>WAGC</sub>	83 MHz, unmodulated. The input such that the pin 2 voltage is 2.0 V or below. (When the keyed AGC is set to 4.0 V.)	104	110	116	dB $\mu$
Conversion gain	A.V	83 MHz, 80 dB $\mu$ , unmodulated. The FE CF output	19	30	48	mVrms
Oscillator buffer output	V <sub>OSCBUFFFM</sub>	No input	85	110	165	mVrms
[NC Block] NC input (pin 30)						
Gate time	$\tau$ GATE1	f = 1 kHz, for a 1- $\mu$ s, 100-mV p-o pulse		55		$\mu$ s
Noise sensitivity	SN	The level of a 1 = kHz, 1- $\mu$ s pulse input that starts noise canceller operation. Measured at pin 30.		40		mVp-o
NC effect	SN-NC	The pulse rejection effect provided by the noise canceller. For a repeated 1- $\mu$ s wide pulse, frequency = 10 kHz, 150 mV p-o. The ratio of the FM mode pin 15 output referenced to the AM mode pin 15 output (effective value)	5			
[Multipath Rejection Circuit] MRC input (pin 27)						
MRC output	VMRC	V <sub>24</sub> = 5 V	2.2	2.3	2.4	V
MRC operating level	MRC-ON	The pin 32 input level at f = 70 kHz such that pin 24 goes to 5 V and pin 27 goes to 2 V	10	15	20	mVrms
[AM Characteristics] AM ANT input						
Practical sensitivity	S/N-30	1 MHz, 30 dB $\mu$ , f <sub>m</sub> = 1 kHz, 30% modulation, pin 15	20			dB
Detector output	V <sub>O-AM</sub>	1 MHz, 74 dB $\mu$ , f <sub>m</sub> = 1 kHz, 30% modulation, pin 15	130	195	270	mVrms
Pin 31 detector output	V <sub>O-AM31</sub>	1 MHz, 74 dB $\mu$ , f <sub>m</sub> = 1 kHz, 30% modulation, pin 31	110	175	230	mVrms
AGC F.O.M.	V <sub>AGC-FOM</sub>	1 MHz, 74 dB $\mu$ , referenced to the output, the input amplitude such that the output falls by 10 dB. Pin 15	51	56	61	dB
Signal-to-noise ratio	S/N-AM	1 MHz, 74 dB $\mu$ , f <sub>m</sub> = 1 kHz, 30% modulation	47	52		dB
Total harmonic distortion	THD-AM	1 MHz, 74 dB $\mu$ , f <sub>m</sub> = 1 kHz, 80% modulation		0.3	1	%
Signal meter output	V <sub>SM AM-1</sub>	No input	0.0	0.2	0.5	V
	V <sub>SM AM-2</sub>	1 MHz, 130 dB $\mu$ , unmodulated	4.8	6	7.3	V
Oscillator buffer output	V <sub>OSCBUFF AM1</sub>	No input, the pin 15 output	185	230		mVrms
Wide band AGC sensitivity	W-AGCsen1	1.4 MHz, the input when V <sub>46</sub> = 0.7 V	92	98	104	dB $\mu$
	W-AGCsen2	1.4 MHz, the input when V <sub>46</sub> = 0.7 V (seek mode)	83	89	95	dB $\mu$
SD sensitivity	SD-sen1 AM	1 MHz, the ANT input level such that the IF counter output turns on.	24	30	36	dB $\mu$
	SD-sen2 AM	1 MHz, the ANT input level such that the SD pin goes to the on state.	24	30	36	dB $\mu$
IF buffer output	V <sub>IFBUFF-AM</sub>	1 MHz, 74 dB $\mu$ , unmodulated. The pin 23 output	200	290		mVrms

Note: These measurements must be made using the either the IC-51-0644-824 or KS8277 IC socket (manufactured by Yamaichi Electronics).

\* 1. When the resistor between pin 58 and ground is 200 k $\Omega$ .

\* 2. When the resistor between pin 58 and ground is 30 k $\Omega$ .

---

**Function List**

## FM Front End (Equivalent to the Sanyo LA1193)

- Double input type double balanced mixer
- Pin diode drive AGC output
- MOSFET second gate drive AGC output
- Keyed AGC adjustment pin
- Differential IF amplifier
- Wide band AGC sensitivity setting pin, and narrow band AGC sensitivity setting pin
- Local oscillator

## FM IF

- IF limiter amplifier
- S-meter output (also used for AM) 6-stage pickup
- Multipath detection pin (shared FM signal meter)
- Quadrature detection
- AF preamplifier
- AGC output
- Band muting
- Weak input muting
- Soft muting adjustment pin
- Muting attenuation adjustment pin
- IF counter buffer output (also used for AM)
- SD (IF counter buffer on level) adjustment pin
- SD output (active high) (also used for AM)

## Noise Canceller

- High-pass filter (first order)
- Delay circuit based low-pass filter (fourth order)
- Noise AGC
- Pilot signal compensation circuit
- Noise sensitivity setting pin
- Function for disabling the noise canceller in AM mode

## Multiplex Functions

- Adjustment-free VCO circuit
- Level follower type pilot canceller circuit
- HCC (high cut control)
- Automatic stereo/mono switching
- VCO oscillation stop function (AM mode)
- Forced monaural
- SNC (stereo noise controller)
- Stereo display pin
- Anti-birdie filter

## AM

- Double balanced mixer (1st, 2nd)
- IF amplifier
- Detection
- RF AGC (narrow/wide)
- Pin diode drive pin
- IF AGC
- Signal meter output (also used for FM)
- Local oscillator circuits (first and second)
- Local oscillator buffer output
- IF counter buffer output (also used by the FM IF)
- SD (IF counter buffer on level) adjustment pin
- SD output (active high) (also used for AM)
- Wide AGC
- Detection output frequency characteristics adjustment pin (low cut, high deemphasis)
- AM stereo buffer

## MRC (multipath noise rejection circuit)

AM/FM switching output (linked to the FM  $V_{CC}$ )

## Operating Characteristics and Symbols Used in the Test Circuit Diagrams

### Switches (SW)

Switch on = 1, SW off = 0

There are two switches that use signal transfer.

— SW2: switches between the mixer input and the IF input.

— SW4: switches between noise canceler input and IF output + noise canceler input.

### Types of SG used

PG1 (AC1)	Used for noise canceler testing. A pulse generator and an AF oscillator are required.
AC2	Used for FM front end testing. Outputs an 83 MHz signal.
AC3	Used for FM IF, noise canceler, and MPX testing. Outputs a 10.7 MHz signal. Stereo modulation must be possible.
AC4	Used for AM testing. Outputs 1 MHz and 1.4 MHz signals.
AC5	Used with the MRC. Can also be used for AF and OSC.

### Power supply

V <sub>CC</sub>	8 V		
V <sub>CC1</sub>	5 V		SD, stereo, seek/stop
V <sub>CC2</sub>	0.1 V / 0.7 V / 2 V / 4 V	These levels must be variable.	Keyed AGC, Mute ATT
V <sub>CC3</sub>	0.1 V / 0.6 V / 2 V		HCC, SNC, SASC (MRC)

### • Switches

	Parameter	ON	OFF
SW1	AM/FM switching. The FE V <sub>CC</sub> is supplied to pin 62.	FM	AM
SW2	FM IF switching. Pin 51/FE output	FE IF OUT (A)	AC3 (B)
SW3	For conversion gain testing	Conversion gain measurement (A)	Other/purposes
SW4	For switching between noise canceler input and IF output + noise canceler.	AC1 (A)	Other/purposes
SW5	High-speed SD	High-speed SD	Other/purposes
SW6	SEEK/STOP (IF BUFF ON/OFF)	STOP	Seek (IF buffer output)
SW7	MUTE ATT 200 kΩ	MUTE 200 kΩ	OFF
SW8	MUTE ATT 30 kΩ	MUTE 30 kΩ	OFF
SW9	For pilot cancellation testing	When pilot cancellation is used	When pilot cancellation is not used
SW10	Mute off (pin 33)	MUTE OFF	MUTE ON

### • Trimmers (variable resistors)

VR1	Separation adjustment
VR2	Pilot cancellation adjustment

### Test Points

#### • DC voltages

VD1	FM RF AGC voltage	Pin 2
VD2	AM/FM SD, AM Tweet, FM stereo indicator	Pin 26
VD3	AM/FM S-meter	Pin 24
VD4	MRC output	Pin 27
VD5	Mute drive output	Pin 33
VD6	AM antenna damping voltage	Pin 46
VD7	N.C. Gate time	Pin 8

#### • AC voltages

VA1	AM/FM OSC Buff	Pin 4
VA2	First IF output	Pin 53 → CF → pin 51 load level (10.7 MHz)
VA3	IF counter buffer	Pin 23 (10.7 MHz/450 kHz)
VA4	MPX OUT Left ch	Pin 15 (AF)
VA5	MPX OUT Right ch	Pin 16 (AF)

Pin Descriptions

Pin No.	Function	Description	Equivalent circuit
1	Antenna damping drive	An antenna damping current flows when the RF AGC voltage (pin 2) reaches $V_{CC} - V_D$ .	
2	RF AGC	Used to control the FET second gate.	
3	F.E.GND		
4	OSC	Oscillator connection	
7	AM OSC	AM first oscillator This circuit can oscillator up to the SW band. An ALC circuit is included.	

A13555

A13556

A13557

A13558

Continued on next page.

LA1787M

Continued from preceding page.

Pin No.	Function	Description	Equivalent circuit
8 9	Noise AGC sensitivity AGC adjustment	After setting up the medium field (about 50 dBμ) sensitivity with the noise sensitivity setting pin (pin 8), set the weak field (about 20 to 30 dBμ) sensitivity with the AGC adjustment pin (pin 9)	
11 12	Memory circuit connection	Recording circuit used during noise canceller operation.	
13	Pilot input	Pin 13 is the PLL circuit input pin.	
14	N.C., MPX, MRC, GND	Ground for the N.C., MPX, and MRC circuits.	

Continued on next page.

# LA1787M

Continued from preceding page.

Pin No.	Function	Description	Equivalent circuit
15 16	MPX output (left) MPX output (right)	Deemphasis 50 $\mu$ s: 0.015 $\mu$ F 75 $\mu$ s: 0.022 $\mu$ F	<p style="text-align: right; font-size: small;">A13562</p>
17	Pilot canceller signal output	Adjustment is required since the pilot signal level varies with the sample-to-sample variations in the IF output level and other parameters.	<p style="text-align: right; font-size: small;">A13563</p>
18	Pilot canceller signal output	Pin 18 is the output pin for the pilot canceller signal.	<p style="text-align: right; font-size: small;">A13564</p>

Continued on next page.



LA1787M

Continued from preceding page.

Pin No.	Function	Description	Equivalent circuit
19	Separation adjustment pin	Use a trimmer to adjust the subdecoder input level. (The output level is not modified in mono and main modes.)	<p style="text-align: right;">A13565</p>
20	VCO	The oscillator frequency is 912 Hz. KBR-912F108 (Kyocera Corporation) CSB-912JF108 (Murata Mfg. Co., Ltd.)	<p style="text-align: right;">A13566</p>
21 22	PHASE COMP. PHASE COMP.		<p style="text-align: right;">A13567</p>

Continued on next page.

LA1787M

Continued from preceding page.

Pin No.	Function	Description	Equivalent circuit
23	IF counter buffer seek/stop switching	<p>This pin functions both as the IF counter buffer (AC output) and as the seek/stop switch pin. The voltage V23 switches between the following three modes.</p> <p>During FM reception:</p> <p>5 V: Seek mode 2.5 V: Forced SD mode 0 V: Reception mode</p> <p>AM reception (two modes: 0 and 5 V)</p> <p>5 V: Seek mode 0 V: Reception mode</p>	
24 32	AM/FM signal meter Dedicated FM signal meter	<p>Fixed-current drive signal meter output</p> <p>In AM mode, pin 32 outputs a 1-mA current. Thus the HCC circuit is turned off.</p>	
26	Stereo indicator for the SD pin	<p>The voltage V23 switches between three modes as follows.</p> <p>FM reception:</p> <p>5 V: The SD pin operates linked to the IF counter buffer. 2.5 V: Forced SD mode: operates as the SD pin. 0.7 V: Reception mode: stereo indicator</p> <p>AM reception: (two modes: 0 and 5 V)</p> <p>5 V: Operates as the seek SD pin. 0 V: Reception mode. Not used.</p>	

Continued on next page.

# LA1787M

Continued from preceding page.

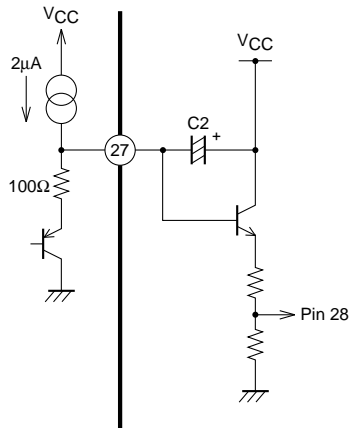
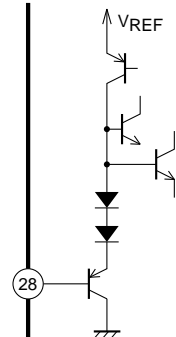
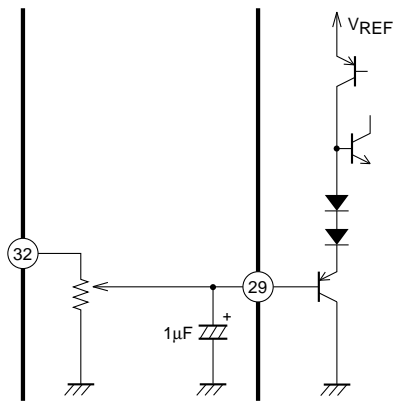
Pin No.	Function	Description	Equivalent circuit
27	MRC control voltage time constant	The MRC detector time constant is determined by a 100 Ω resistor and C2 when discharging and by the 2-μA current and C2 when charging.	 <p style="text-align: right;">A13571</p>
28	SNC control input	The sub-output is controlled by a 0 to 1-V input.	 <p style="text-align: right;">A13572</p>
29	HCC control input	<p>The high band frequency output is controlled by a 0 to 1-V input.</p> <p>It can also be controlled by the MRC output.</p> <p>Use a resistor of at least 100 kΩ when controlling with the pin 32 FM S-meter signal.</p>	 <p style="text-align: right;">A13573</p>

Continued on next page.

# LA1787M

Continued from preceding page.

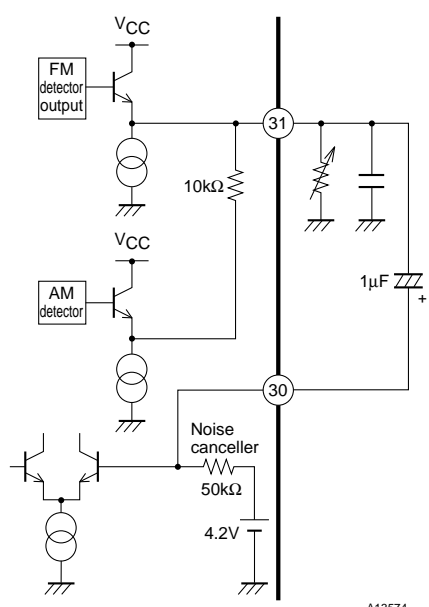
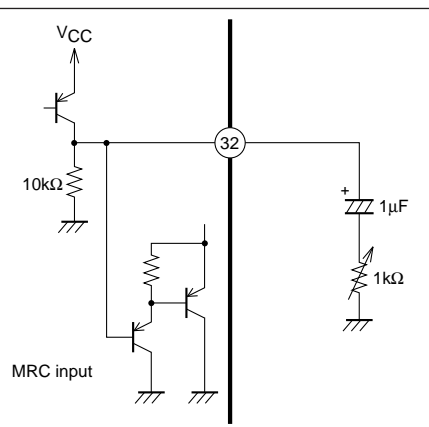
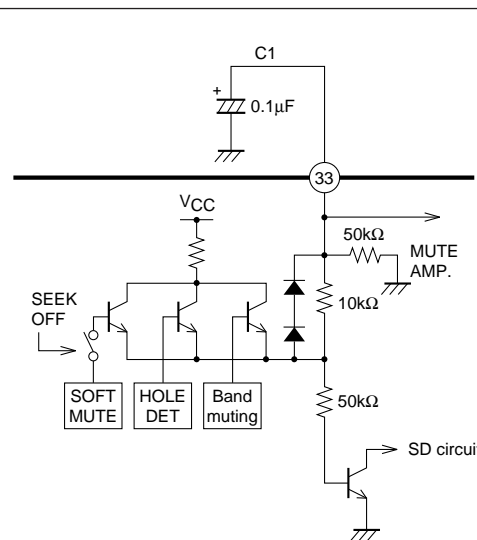
Pin No.	Function	Description	Equivalent circuit
30	Noise canceller input	Pin 30 is the noise canceller input. The input impedance is 50 kΩ.	 <p style="text-align: right; font-size: small;">A13574</p>
31	AM/FM detector output	Pin 31 is the AM and FM detector output In FM mode, this is a low-impedance output. In AM mode, the output impedance is 10 kΩ. To improve the low band separation, use a coupling capacitor of over 10 μF.	
32	IF S-meter output and MRC DC input	FM S-meter output block MRC AC input block Adjust the external 1-kΩ resistor to attenuate the MRC AC input and control the circuit.	 <p style="text-align: right; font-size: small;">A13575</p>
33	Mute drive output	<ul style="list-style-type: none"> <li>•The muting time constant is determined by an external RC circuit as described below. Attack time: <math>T_A = 10 \text{ k}\Omega \times C1</math> Release time: <math>T_R = 50 \text{ k}\Omega \times C1</math></li> <li>•Noise convergence adjustment The noise convergence can be adjusted when there is no input signal by inserting a resistor between pin 33 and ground.</li> <li>•Muting off function Ground pin 33 through a 4-kΩ resistor.</li> </ul>	 <p style="text-align: right; font-size: small;">A13576</p>

Continued on next page.

# LA1787M

Continued from preceding page.

Pin No.	Function	Description	Equivalent circuit
34 35 36 37	AGC QD output QD input $V_{REF}$	<ul style="list-style-type: none"> <li>•The resistor <math>R_1</math> determines the width of the band muting function. Increasing the value of <math>R_1</math> narrows the band. Reducing the value of <math>R_1</math> widens the band.</li> <li>•Null voltage When tuned, the voltage between pins 34 and 37, <math>V_{34-37}</math>, will be 0 V. The band muting function turns on when <math> V_{34-37}  \geq 0.7</math> V.</li> </ul> <p><math>V_{37} = 4.9</math> V</p>	<p style="text-align: right; font-size: small;">A13577</p>
38	FM SD ADJ	<p>A 130-<math>\mu</math>A current flows from pin 38 and, in conjunction with the external resistance R, determines the comparison voltage.</p>	<p style="text-align: right; font-size: small;">A13578</p>
39	Keyed AGC AM stereo buffer	<p>The keyed AGC operates when the voltage created by dividing the pin 24 S-meter output voltage by the 6.4 and 3.6 k<math>\Omega</math> resistors becomes lower than the voltage determined by the resistor between pin 39 and ground.</p> <p>This pin also is used as the AM stereo IF buffer pin.</p>	<p style="text-align: right; font-size: small;">A13579</p>

Continued on next page.

# LA1787M

Continued from preceding page.

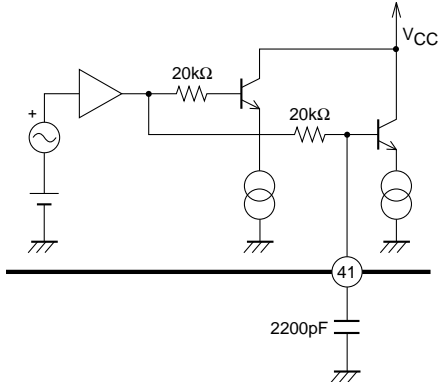
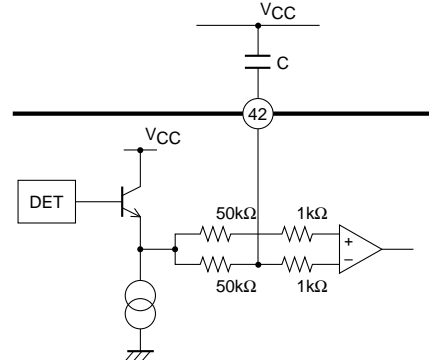
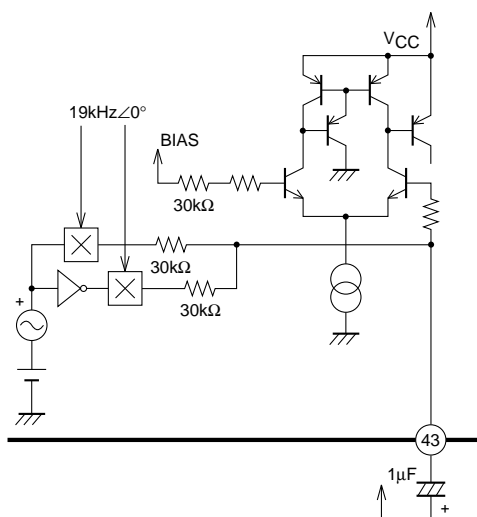
Pin No.	Function	Description	Equivalent circuit
41	HCC capacitor	<p>The HCC frequency characteristics are determined by the external capacitor connected at this pin.</p>	 <p style="text-align: right; font-size: small;">A13580</p>
42	AM L.C. pin	<p>This pin is used to change the frequency characteristics of the unneeded audio band under 100 Hz in AM mode to produce a clear audio signal.</p> <p>Note: The LC capacitor must be connected between this pin and V<sub>CC</sub> (pin 40). This is because the detector circuit operates referenced to V<sub>CC</sub>.</p> <p>The cutoff frequency <math>f_C</math> is determined by the following formula.</p> $f_C = 1/2\pi \times 50 \text{ k}\Omega \times C$	 <p style="text-align: right; font-size: small;">A13581</p>
43	Pilot detector	<p>Inserting a 1-MΩ resistor between pin 43 and V<sub>CC</sub> will force the IC to mono mode.</p>	 <p style="text-align: right; font-size: small;">A13582</p>

Continued on next page.

# LA1787M

Continued from preceding page.

Pin No.	Function	Description	Equivalent circuit
44	IF AGC	<p>G1; Used for time constant switching during seeks.</p> <ul style="list-style-type: none"> <li>• Reception <math>\tau = 2.2 \mu\text{F} \times 300 \text{ k}\Omega</math></li> <li>• Seek <math>\tau = 2.2 \mu\text{F} \times 10 \Omega</math></li> </ul> <p>The external capacitors are connected to <math>V_{CC}</math>. This is because the IF amplifier operates referenced to <math>V_{CC}</math>.</p>	<p style="text-align: right; font-size: small;">A13583</p>
45	IF output	<p>The IF amplifier load</p>	<p style="text-align: right; font-size: small;">A13584</p>
46	AM antenna damping drive output Wide band AGC input	<p><math>I_{46} = 6 \text{ mA}</math> (maximum) This is the antenna damping current.</p>	<p style="text-align: right; font-size: small;">A13585</p>

Continued on next page.

# LA1787M

Continued from preceding page.

Pin No.	Function	Description	Equivalent circuit
47	FM muting on level adjustment	Modify the value of the external resistor to adjust the muting on level.	<p style="text-align: right;">A13586</p>
48 57	RF AGC bypass RF AGC	RF AGC rectification capacitor The low frequency distortion is determined as follows: Increasing C48 and C57 improves the distortion but makes the response slower. Reducing C48 and C57 aggravates the distortion but makes the response faster.	<p style="text-align: right;">A13587</p>
50 51	IF bypass FM IF input	Due to the high gain of the limiter amplifier, care must be taken when choosing the grounding point for the limiter amplifier input capacitor to prevent oscillation.	<p style="text-align: right;">A13588</p>
52	IF input	The input impedance is 2 kΩ.	<p style="text-align: right;">A13589</p>

Continued on next page.



# LA1787M

Continued from preceding page.

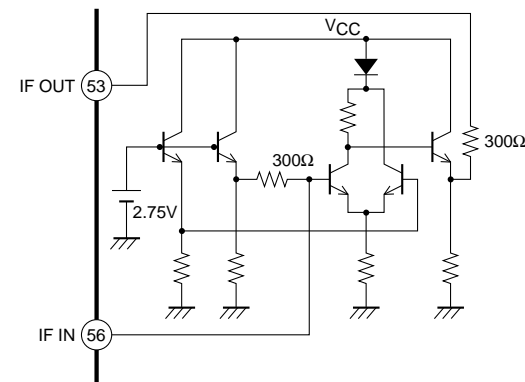
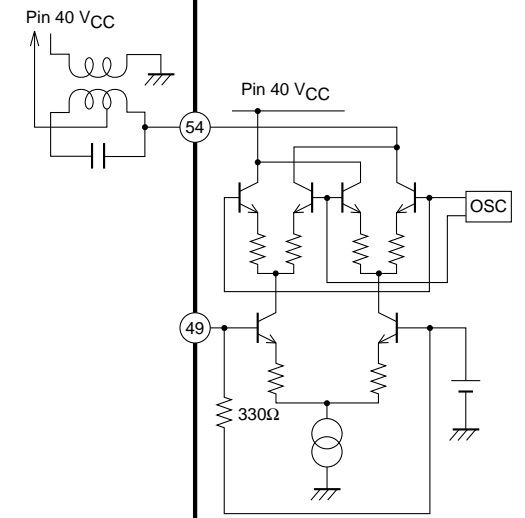
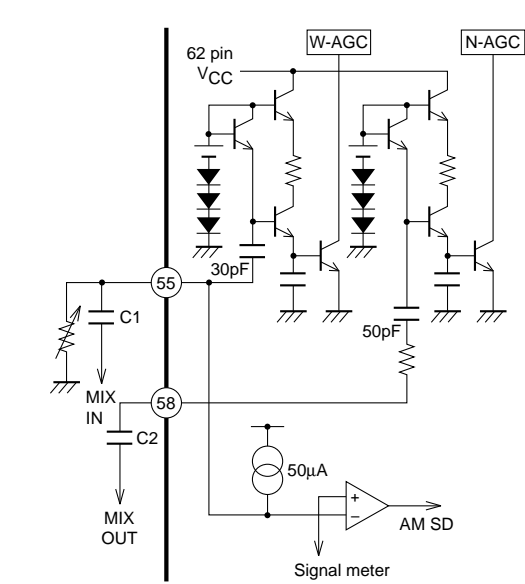
Pin No.	Function	Description	Equivalent circuit
53 56	IF amplifier output IF amplifier input	<ul style="list-style-type: none"> <li>• Input and output pin or the first IF amplifier</li> <li>• Inverting amplifier</li> </ul> <p>V56 = 2 V Input impedance: <math>R_{IN} = 330 \Omega</math></p> <p>V53 = 5.3 V Output impedance <math>R_{OUT} = 330 \Omega</math></p>	 <p style="text-align: right; font-size: small;">A13590</p>
54 49	Mixer output: 130 $\mu$ A Mixer input	<p>The mixer coil connected to the pin 54 mixer output must be wired to <math>V_{CC}</math> (pin 40).</p> <p>The pin 49 mixer input impedance is 330 <math>\Omega</math>.</p>	 <p style="text-align: right; font-size: small;">A13591</p>
55 58	W-AGC IN AM SD ADJ  N-AGC IN Muting attenuation adjustment pin	<p>Pins 55 and 58 include built-in DC cut capacitors.</p> <p>The AGC on level is determined by the values of the capacitors C1 and C2.</p> <p>Pin 55 functions as the SD sensitivity adjustment pin in AM mode.</p> <p>The output current I55 is 50 <math>\mu</math>A, and V55 varies depending on the value of the external resistor.</p> <p>The SD function operates by comparing V55 with the S-meter voltage.</p>	 <p style="text-align: right; font-size: small;">A13592</p>

Continued on next page.

# LA1787M

Continued from preceding page.

Pin No.	Function	Description	Equivalent circuit						
59 60  63 64	Mixer output   Mixer input	<p>Double balanced mixer Pins 59 and 60 are the mixer 10.7-MHz output</p> <p>Pins 63 and 64 are the mixer input. This is an emitter insertion type circuit, and the amount of insertion is determined by the capacitors C1 and C2.</p> <p>Note: The lines for pins 63 and 64 must be kept separated from the lines for pins 59 and 60.</p>	<p style="text-align: right; font-size: small;">A13593</p>						
6	Front end V <sub>CC</sub> AM/FM switching	<p>Pin 6 functions both as the FM front end V<sub>CC</sub> and the AM/FM switching circuit.</p> <table border="1" style="margin-left: auto; margin-right: auto; border-collapse: collapse;"> <thead> <tr> <th style="padding: 2px;">V6 voltage</th> <th style="padding: 2px;">Mode</th> </tr> </thead> <tbody> <tr> <td style="padding: 2px;">When 8 V →</td> <td style="padding: 2px;">FM</td> </tr> <tr> <td style="padding: 2px;">OPEN →</td> <td style="padding: 2px;">AM</td> </tr> </tbody> </table>	V6 voltage	Mode	When 8 V →	FM	OPEN →	AM	<p style="text-align: right; font-size: small;">A13594</p>
V6 voltage	Mode								
When 8 V →	FM								
OPEN →	AM								
62	1st MIX INPUT	<p>First mixer input The input impedance is about 10 kΩ.</p>	<p style="text-align: right; font-size: small;">A13595</p>						
10	AM 2nd OSC	<p>Crystal oscillator circuit The Kinseki, Ltd. HC-49/U-S and a C<sub>L</sub> of 20 pF must be used.</p>	<p style="text-align: right; font-size: small;">A13596</p>						

Block Diagram

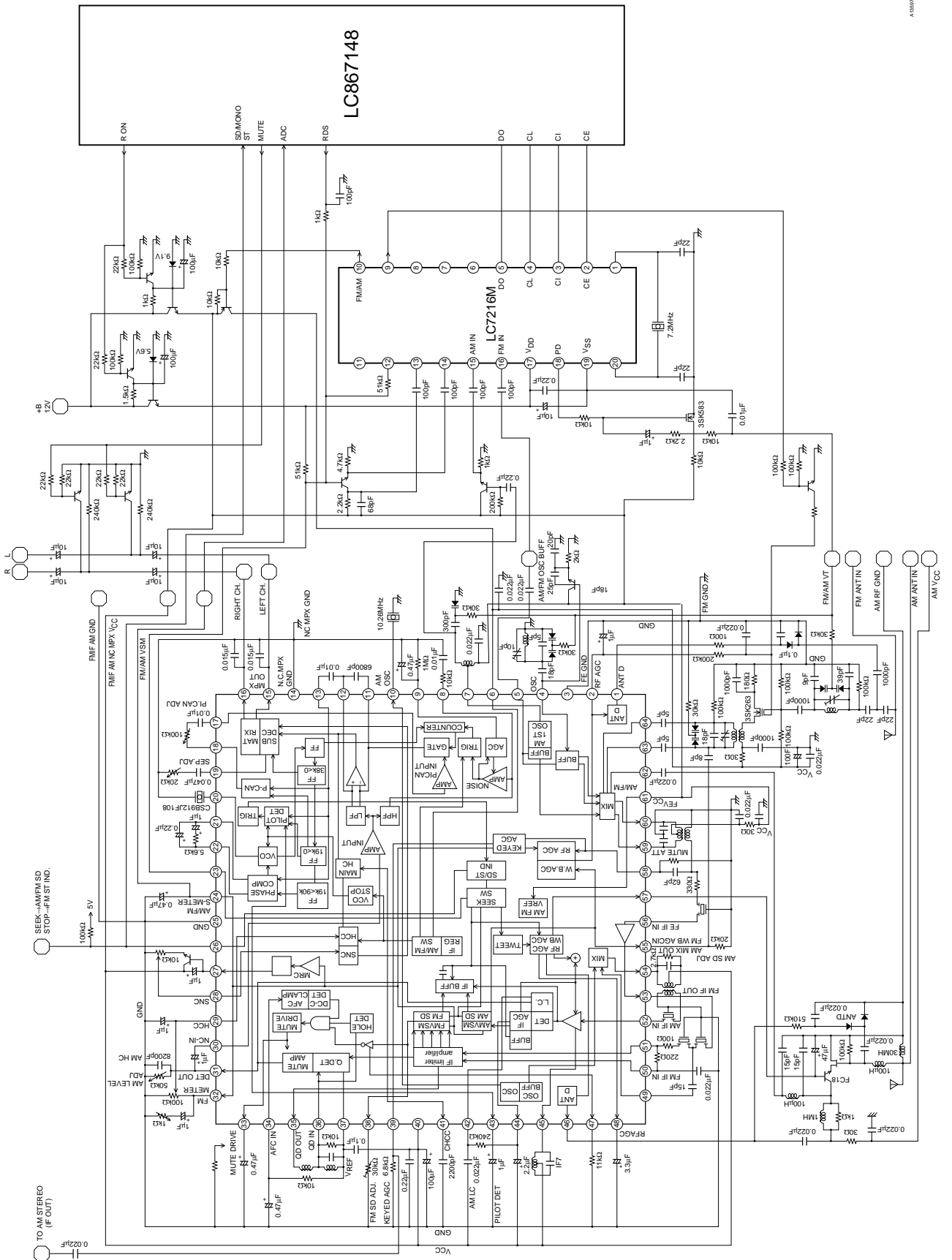

A10007

AC Characteristics Test Circuit

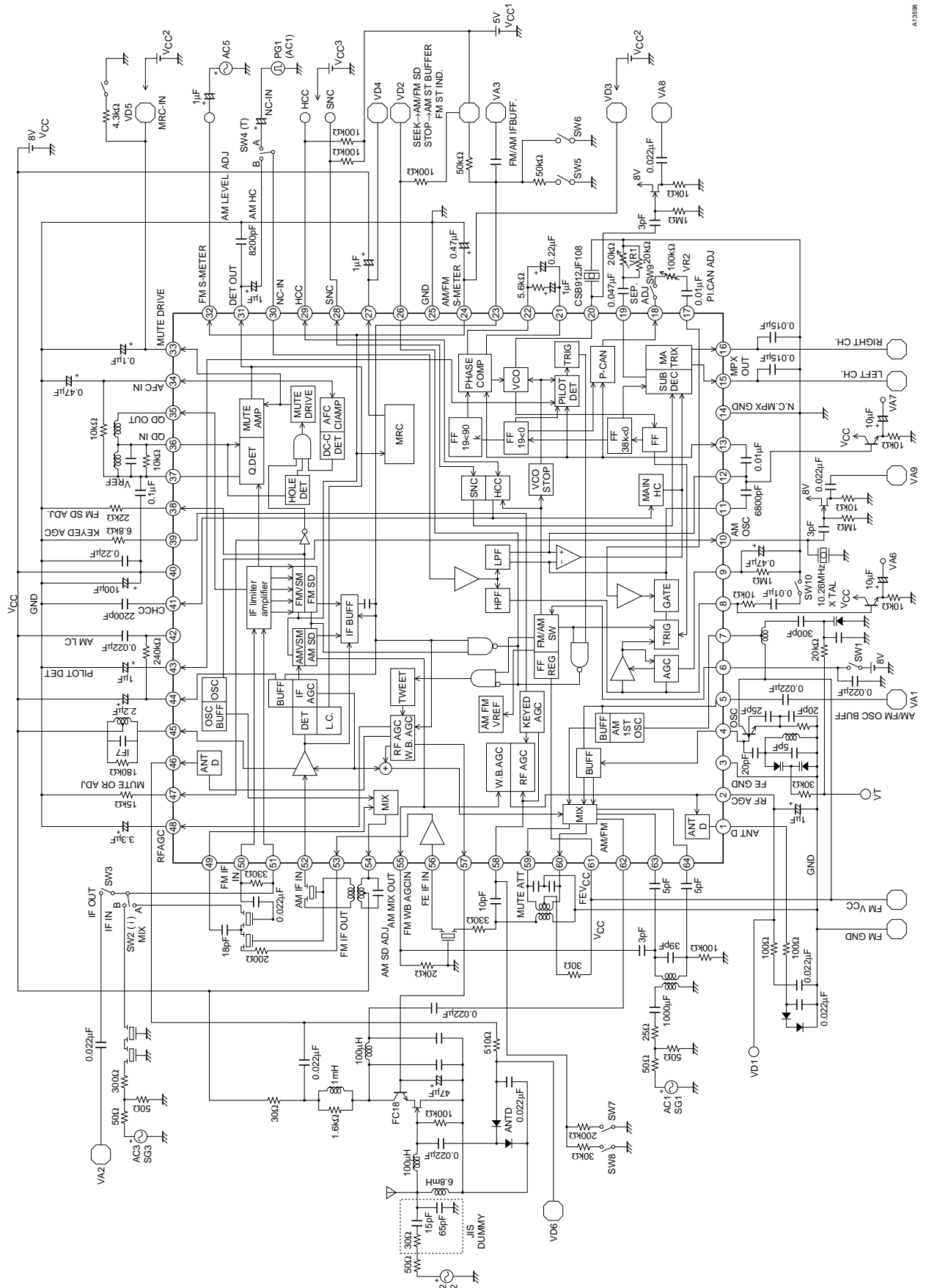

A13588

## LA1787M

### Test Conditions

Parameter	Symbol	Switch states									
		SW1	SW2	SW3	SW4	SW5	SW6	SW7	SW8	SW9	SW10
Current drain	I <sub>CCO-FM</sub>	ON	b	OFF	b	—	ON	OFF	OFF	ON	—
Demodulation output	V <sub>O-FM</sub>	ON	b	OFF	b	—	ON	OFF	OFF	ON	—
Pin 31 demodulation output	V <sub>O-FM31</sub>	ON	b	OFF	b	—	ON	OFF	OFF	ON	—
Channel balance	CB	ON	b	OFF	b	—	ON	OFF	OFF	ON	—
Total harmonic distortion (FM)	THD-FMmono	ON	b	OFF	b	—	ON	OFF	OFF	ON	—
Signal-to-noise ratio: IF	S/N-FM IF	ON	b	OFF	b	—	ON	OFF	OFF	ON	—
AM suppression ratio: IF	AMR IF	ON	b	OFF	b	—	ON	OFF	OFF	ON	—
Muting attenuation	Att-1	ON	b	OFF	b	—	ON	OFF	OFF	ON	—
	Att-2	ON	b	OFF	b	—	ON	OFF	OFF	ON	—
	Att-3	ON	b	OFF	b	—	ON	OFF	OFF	ON	—
Separation	Separation	ON	b	OFF	b	—	ON	OFF	OFF	ON	—
Stereo on level	ST-ON	ON	b	OFF	b	—	ON	OFF	OFF	ON	—
Stereo off level	ST-OFF	ON	b	OFF	b	—	ON	OFF	OFF	ON	—
Main total harmonic distortion	THD-Main L	ON	b	OFF	b	—	ON	OFF	OFF	ON	—
Pilot cancellation	PCAN	ON	b	OFF	b	—	ON	OFF	OFF	OFF/ON	—
SNC output attenuation	AttSNC	ON	b	OFF	b	—	ON	OFF	OFF	ON	—
HCC output attenuation 1	AttHCC-1	ON	b	OFF	b	—	ON	OFF	OFF	ON	—
HCC output attenuation 2	AttHCC-2	ON	b	OFF	b	—	ON	OFF	OFF	ON	—
Input limiting voltage	V <sub>i-lim</sub>	ON	b	OFF	b	—	ON	OFF	OFF	ON	ON
Muting sensitivity	V <sub>i-mute</sub>	ON	b	OFF	b	—	ON	OFF	OFF	ON	—
SD sensitivity 1	SD-sen1 FM	ON	b	OFF	b	OFF	OFF	OFF	OFF	ON	—
SD sensitivity 2	SD-sen2 FM	ON	b	OFF	b	ON	OFF	OFF	OFF	ON	—
IF counter buffer output	V <sub>IFBUFF-FM</sub>	ON	b	OFF	b	OFF	OFF	OFF	OFF	ON	—
Signal meter output (FM)	V <sub>SM FM-1</sub>	ON	b	OFF	b	—	ON	OFF	OFF	ON	—
	V <sub>SM FM-2</sub>	ON	b	OFF	b	—	ON	OFF	OFF	ON	—
	V <sub>SM FM-3</sub>	ON	b	OFF	b	—	ON	OFF	OFF	ON	—
	V <sub>SM FM-4</sub>	ON	b	OFF	b	—	ON	OFF	OFF	ON	—
Muting bandwidth	BW-mute	ON	b	OFF	b	—	ON	OFF	OFF	ON	—
Mute drive output	V <sub>MUTE-100</sub>	ON	b	OFF	b	—	ON	OFF	OFF	ON	—
N-AGC on input	V <sub>NAGC</sub>	ON	a	ON	b	—	ON	OFF	OFF	—	—
W-AGC on input	V <sub>WAGC</sub>	ON	a	ON	b	—	ON	OFF	OFF	—	—
Conversion gain	A.V	ON	a	ON	b	—	ON	OFF	OFF	—	—
Oscillator buffer output	V <sub>OSCBUFFFM</sub>	ON	a	ON	b	—	ON	OFF	OFF	—	—
Gate time 1	τ <sub>GATE1</sub>	ON	—	OFF	a	—	ON	OFF	OFF	—	—
Noise sensitivity	SN	ON	—	OFF	a	—	ON	OFF	OFF	—	—
NC effect	SN-NC	ON/OFF	—	OFF	a	—	ON	OFF	OFF	—	—
MRC output	V <sub>MRC</sub>	ON	—	OFF	b	—	ON	OFF	OFF	—	—
MRC operating level	MRC-ON	ON	—	OFF	b	—	ON	OFF	OFF	—	—
Practical sensitivity	S/N-30	OFF	—	OFF	b	ON	ON	—	—	—	—
Detection output	V <sub>O-AM</sub>	OFF	—	OFF	b	ON	ON	—	—	—	—
Pin 31 detection output	V <sub>O-AM31</sub>	OFF	—	OFF	b	ON	ON	—	—	—	—
AGC F.O.M.	V <sub>AGC-FOM</sub>	OFF	—	OFF	b	ON	ON	—	—	—	—
Signal-to-noise ratio	S/N-AM	OFF	—	OFF	b	ON	ON	—	—	—	—
Total harmonic distortion (AM)	THD-AM	OFF	—	OFF	b	ON	ON	—	—	—	—
Signal meter output (AM)	V <sub>SM AM-1</sub>	OFF	—	OFF	b	ON	ON	—	—	—	—
	V <sub>SM AM-2</sub>	OFF	—	OFF	b	ON	ON	—	—	—	—
Oscillator buffer output	V <sub>OSCBUFF AM-1</sub>	OFF	—	OFF	b	ON	ON	—	—	—	—
Wide band AGC sensitivity	W-AGCsen 1	OFF	—	OFF	b	ON	ON	—	—	—	—
	W-AGCsen 2	OFF	—	OFF	b	ON	ON	—	—	—	—
SD sensitivity	SD-sen1 AM	OFF	—	OFF	b	OFF	OFF	—	—	—	—
	SD-sen2 AM	OFF	—	OFF	b	OFF	OFF	—	—	—	—
IF buffer output	V <sub>IFBUFF-AM</sub>	OFF	—	OFF	b	OFF	OFF	—	—	—	—

**Usage Notes**

1. Notes on  $V_{CC}$  and Ground

Pin 40	$V_{CC}$ for the FM IF, AM, NC, MPX, and MRC blocks
Pin 25	Ground for the FM IF and AM blocks
Pin 14	Ground for the NC, MPX, and MRC blocks
Pin 61	$V_{CC}$ for the FM front end, AM first mixer, and first oscillator blocks
* Pin 6	$V_{CC}$ for the FM front end and AGC blocks, and the AM/FM switching pin
Pin 3	Ground for the FM front end, first mixer, and first oscillator blocks

\*: When applying the  $V_{CC}$  voltage to pin 6, that voltage must not exceed the pin 40 and pin 61  $V_{CC}$  voltages. (This condition must be checked carefully when first applying the pin 6 voltage.)

2. Notes on AM Coil Connection

The  $V_{CC}$  used for the first oscillator coil connected to pin 7 must be at the same potential as pin 61. Connect to the IFT connected with pin 45, and to the MIX coil connected with pin 54.  $V_{CC}$  must be at the same potential as pin 40.

3. AM/FM Switching

Pin 6 is also used as the FM front end and RF AGC  $V_{CC}$

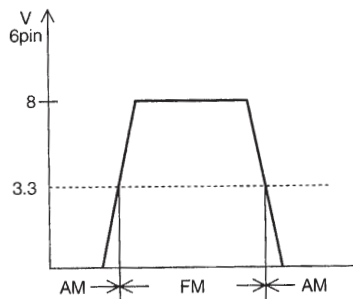

Pin 6 voltage	Mode
8	FM
OPEN	AM

Fig. 1

A06620

**LA1787M Overview**

1. Notes on the LA1781M, LA1784M, and LA1787M

The LA1784M is a version of the LA1781M that uses an external oscillator circuit, and has the same characteristics as the LA1781M.

The LA1787M is a version of the LA1784M that features improved characteristics.

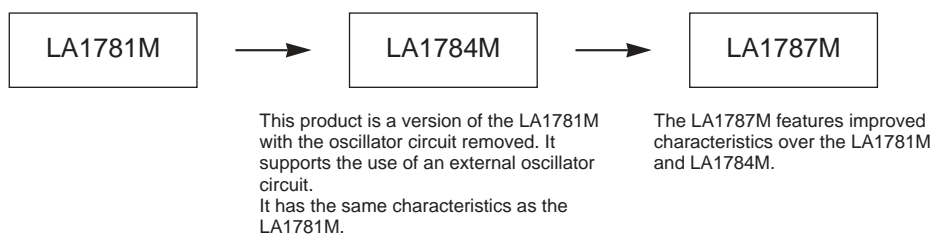

2. Modified circuits

The following characteristics have been improved over those of the The LA1784M.

- The AM adjacent channel interference characteristics ( $\Delta 40$  kHz) have been improved.
- The AM S-meter curve slope has been increased.
- The FM separation temperature characteristics have been improved.
- The stereo indicator sensitivity has been improved.
- The FM oscillator circuit has been omitted.

(1) AM interference characteristics improvement

The second signal interference and suppression have been improved for adjacent channels ( $\pm 40$  kHz) by increasing the AM second mixer input dynamic range.

(2) The AM S-meter curve slope has been increased.

The slope of the AM S-Meter curve has been increased from that of the LA1781M and LA1784M.

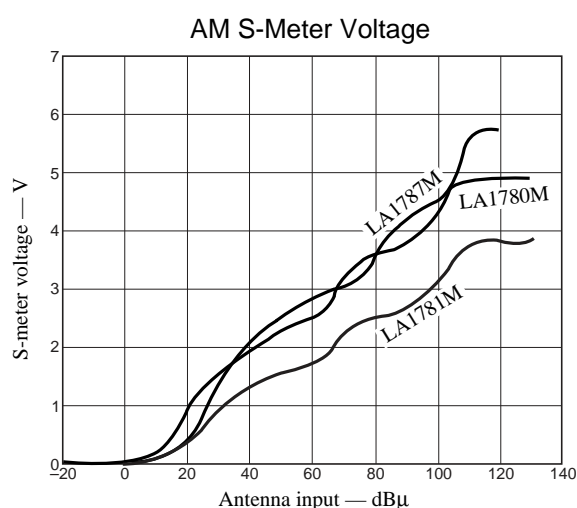

(3) FM separation temperature characteristics improvement

The temperature characteristics have been improved, the amount of change in the separation due to drift when at power on has been stabilized. This makes it easier to adjust the separation.

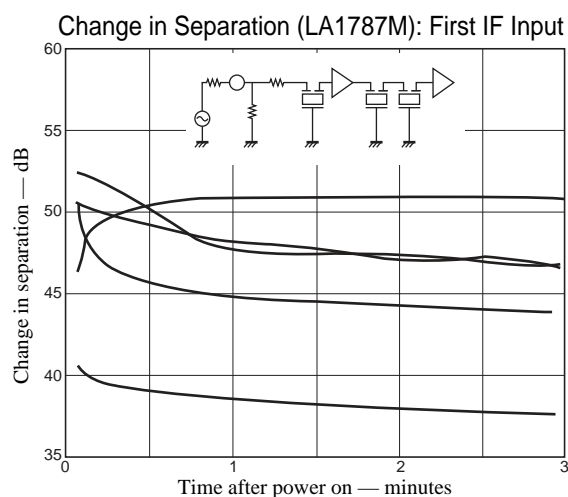
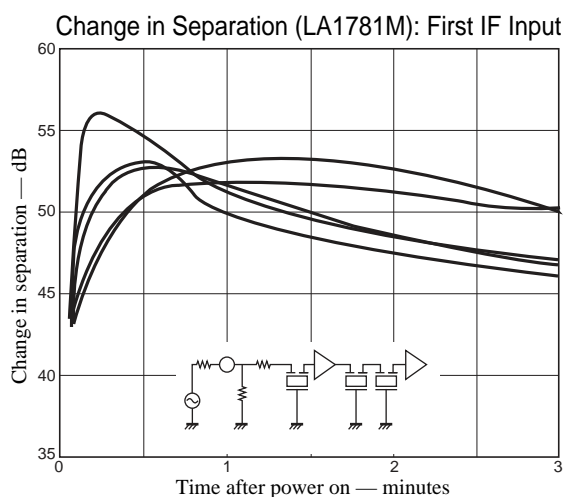

(4) Stereo indicator sensitivity improvement

The stereo indicator sensitivity (on/off) is equivalent to that of the LA1780M

	Stereo on level	Stereo off level
LA1781M/1784M	4.1%	3.1%
LA1787M/1780M	2.6%	1.6%

(Typical value)

\*: The pilot level such that the stereo indicator goes on or off for a 10.7 MHz unmodulated IF input.

(5) FM oscillator circuit removed

The internal FM oscillator circuit provided in the LA1781M has been removed. The FM oscillator level can be adjusted by constructing an external circuit block.

\*: However, this requires 4 more external parts than the LA1781M: 1 transistor and 3 resistors/capacitors.

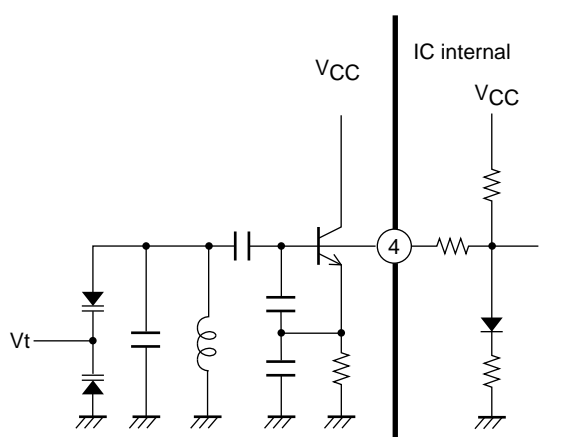

A13600

LA1787M/1784M FM OSC

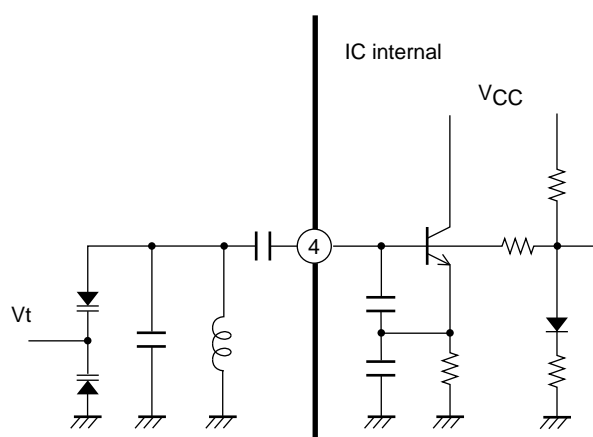

A13601

LA1780M/1781M FM OSC

3. Gain distribution

The table below shows the gain distribution of the LA1780M, LA1784M, and LA1787M. (These are measured values.) Compared to the LA1784M, the total gain is lower.

	1st MIX (10.7)	1st IF (10.7)	2nd MIX (450)	2nd IF (450)
LA1780M	10 dB	3.3 dB	3.2 dB	69 dB
LA1784M	7.5 dB	13 dB	7 dB	66 dB
LA1787M	7.5 dB	3.5 dB	8.6 dB	67 dB

First mixer : No circuit changes from the LA1784M.

First IF amplifier : Equivalent to the LA1780M circuit. (The gain is lower than that in the LA1781M and LA1784M.)

Second mixer : The mixer circuit has been modified to improve adjacent channel suppression and interference.

Second IF amplifier : Equivalent to the LA1780M circuit.



4. Changes to applications

Component values that change from LA1781M/LA1784M applications  
(Since the total AM gain has changed in the LA1787M)

- AM SD adjustment resistor (pin 55): Because  $V_{sm}$  is higher.
- AM level adjustment resistor (pin 31): Since the post-detection audio amplifier gain is higher than in the LA1781M and LA1784M, the output level is also higher. This resistor must be changed to match the set value.
- AM mixer coil (pin 54), IFT coil (pin 45) damp resistor: Since the IF block gain is increased, the mixer (pin 54) and IFT (pin 45) coil damping must be adjusted.
- Separation adjustment resistor (pin 19): Since an internal 4 kΩ resistor has been added to the pin 19 input circuit to improve the separation temperature characteristics, the value of the external resistor must be reduced from that used with the LA1780M, LA1781M, and LA1784M. (See the following page.)

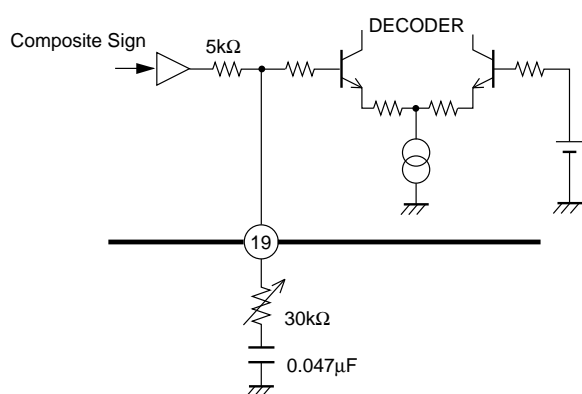

LA1781M/1784M

A13602

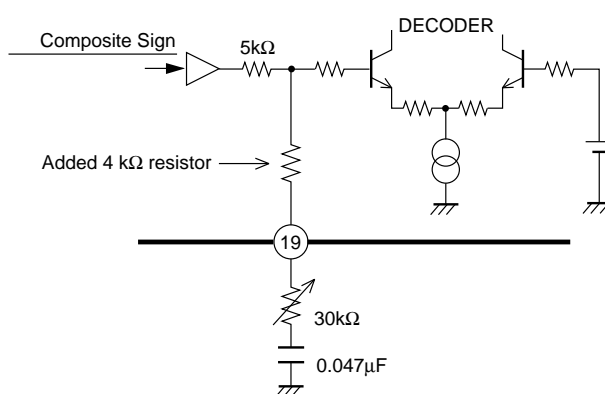

LA1787M

A13603

Functions

1. Notes on the FM Front End

Notes on interference rejection characteristics

- Intermodulation characteristics

The LA1787M applies two high-band AGC functions to prevent IM (the generation of intermodulation). These are the narrow AGC (pin 58: mixer input detection type) and the wide AGC (for the pin 55 input), and this results in the antenna frequency characteristics shown in figure 2. The levels at which the AGC functions turn on are determined by the capacitors attached at pins 55 and 58.

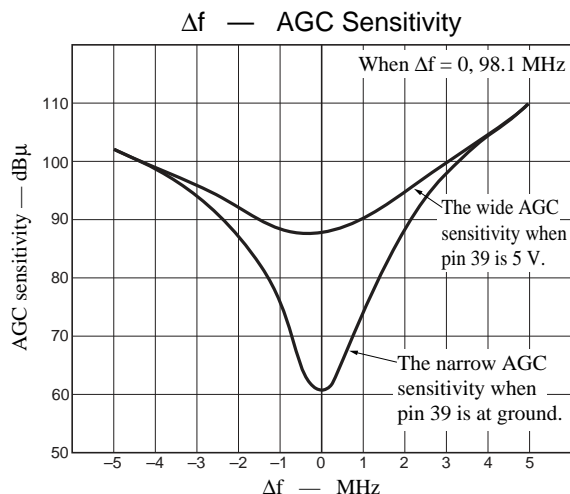

Fig. 2

• Notes on second-channel attenuation suppression

Keyed AGC (3D AGC) is a technique for achieving good characteristics for both intermodulation and second-channel attenuation at the same time. When the desired signal is faint or nonexistent, the high-band AGC level will be essentially 0, and as a result automatic tuning may malfunction and blocking oscillation may occur in the presence of strong interfering stations. Keyed AGC helps resolve these problems.

This 3D AGC technique uses information that has the following three frequency characteristics and is a unique Sanyo-developed system for determining the high-band AGC level.

RF and ANT circuit information: Mixer input AGC

Mixer circuit information: Mixer output AGC

CF selectivity information: S-meter output

• 3D AGC Features

Feature	Merit
Only the narrow AGC sensitivity (operation at $\Delta f < 1.5$ MHz) is controlled by the field strength of the desired station.	• Effective in resolving second-channel attenuation problems.
The narrow AGC sensitivity is controlled by a voltage ( $V_{23}$ ) that is under 0.5 V.	• Allows effective resolution of second-channel attenuation problems without degrading three-signal characteristics.
The wide AGC can operate even when $V_{23} = 0$ (when the desired station is not present).	• Seek operations may stop incorrectly due to the occurrence of intermodulation. • It is possible to prevent the occurrence of intermodulation in the RF tuning circuit and antenna in the presence of strong interfering stations, and blocking oscillation due to AGC operation can be prevented.
The narrow and wide AGC sensitivities can be set independently. (See figure 3 and 4.)	• Settings can be optimized for the field conditions.
The system has two AGC systems: narrow and wide AGC. (See figure 5.)	• Since the narrow AGC operates for the desired station and adjacent stations, the wide AGC sensitivity can be lowered and AGC malfunction due to local oscillator signal can be prevented.

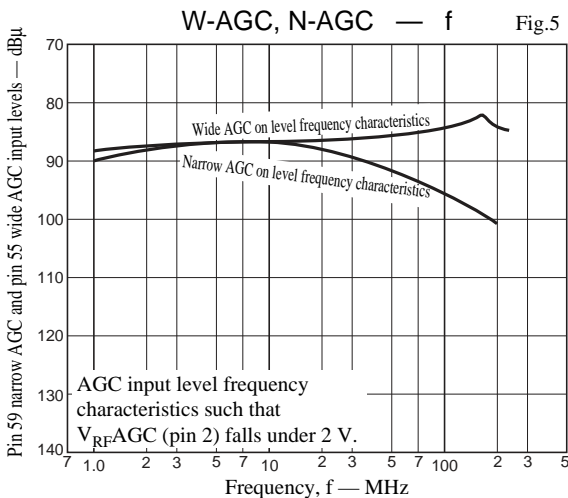
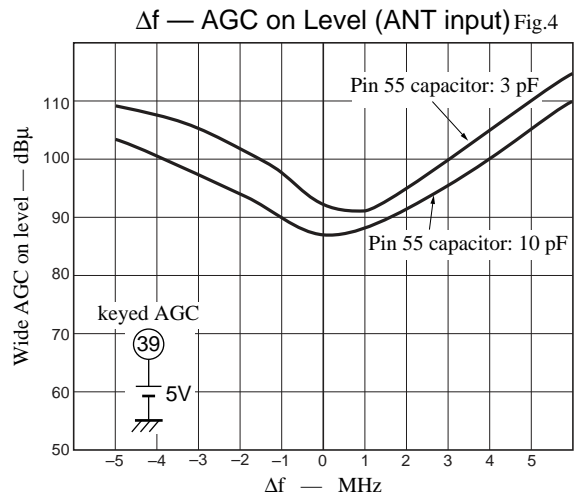
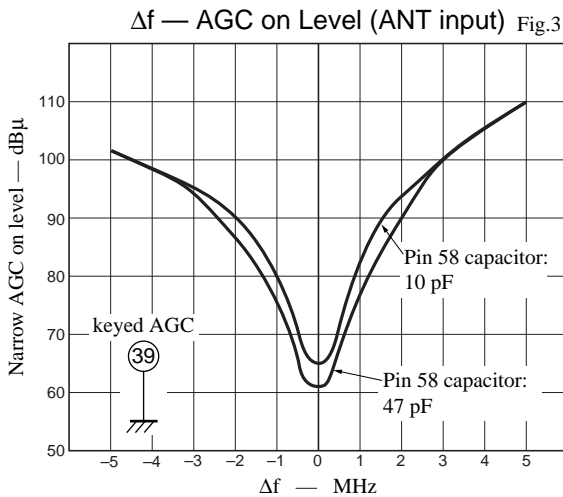

3D AGC Sensitivity Characteristics

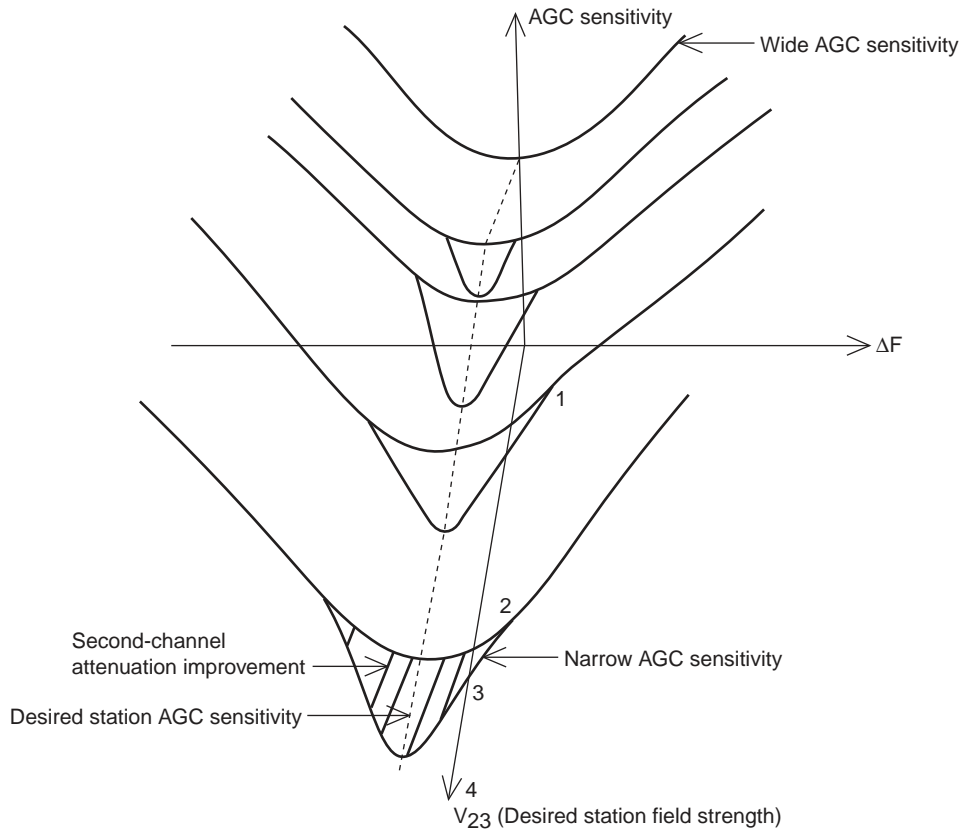

A12075

Fig. 6

3D AGC Sensitivity — Δf, V<sub>23</sub> characteristics

- The wide AGC sensitivity is determined by the antenna and RF circuit selectivity, regardless of V<sub>23</sub>.
- The narrow AGC sensitivity is determined by the following.  
 The total selectivity of the antenna, RF circuit, and mixer when V<sub>23</sub> ≥ 0.5 V  
 The above selectivity and V<sub>23</sub> when V<sub>23</sub> < 0.5 V
- The improvement in the second-channel attenuation corresponds to the area occupied by the narrow AGC in the total AGC sensitivity area.

Figure 8 on the next page shows the actual operation of the circuit.

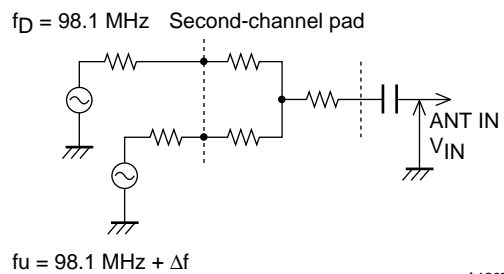
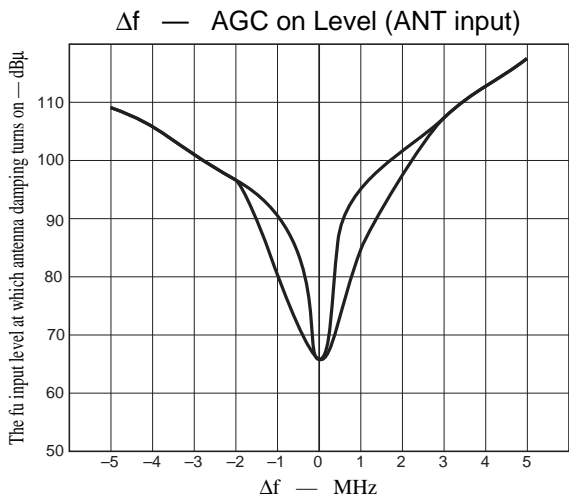

A12076

Fig. 7

Notes on 3D AGC (Keyed AGC)

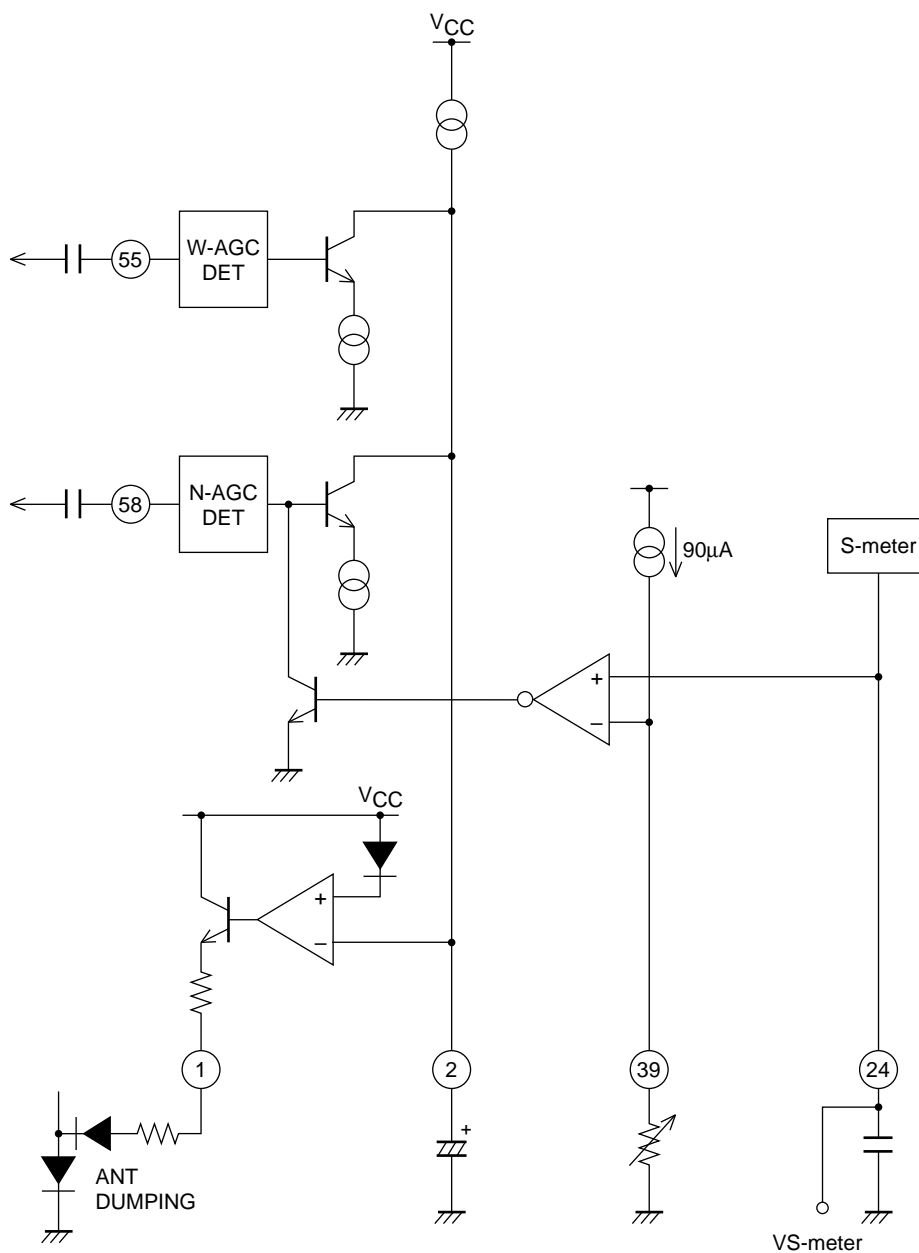

A11763

Fig. 8

- The antenna damping current from the pin due to the pin diode flows when the V2 pin reaches the  $V_{CC} - V_{BE}$  level.
- The narrow AGC operates as follows.  
 When pin V39 > pin V24: The narrow AGC turns off.  
 When pin V39 < pin V24: The narrow AGC turns on.

- The LA1787M includes two AGC circuits in its front end block.
  - Antenna input limiter using a pin diode.
  - FET second gate control

The AGC input pin is pin 59, and the AGC circuit turns on when a signal of about 30 mVrms is input.

AGC activation

The pin diode drive circuit turns on when  $V_{CC} - V_2$  is greater than or equal to about 1 V, and input limitation is applied to the antenna circuit. In application circuits, there will be an attenuation of about 30 to 40 dB. Next, when an adequate current flows in the antenna attenuator pin diode, the inductance falls, the FET second gate voltage drops, the FET gm falls, and the AGC operates. The recommended FET is the Sanyo 3SK263, which is an enhancement-type MOSFET. Therefore, full AGC is applied when the voltage,  $V_{G2-S}$ , between the second gate and the source is 0. Note that if a depletion-type MOSFET is used, AGC will not be applied unless  $V_{G2-S}$  is less than 0.

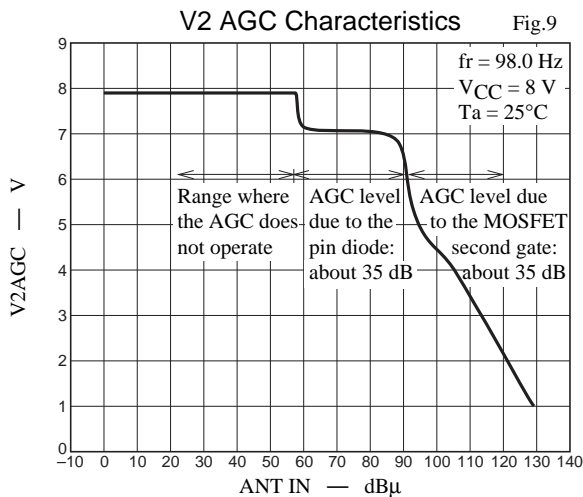

- Mixer
  - The mixer circuit in this IC is a double-balanced mixer with both balanced input and balanced output.

Input circuit type  
 Emitter input  
 Input impedance: 25 Ω

Due to optimized device geometry, emitter current, the bias, this IC achieves the following performance.

Mixer input usable sensitivity: 15 dBμ  
 Mixer input IMQS: 90.5 dBμ  
 (For an oscillator level of 200 mVrms)

\* The mixer input IMQS is defined as:

fr = 98.8 MHz, no input  
 fu1 = 98.8 MHz, 1 kHz, 30% modulation  
 fu2 = 99.6 MHz, no modulation

The interference 1 and 2 input levels such that generated intermodulation output signal-to-noise ratio becomes 30 dB when an interference signal with the same level as the mixer input is input, and distortion occurs in the mixer.

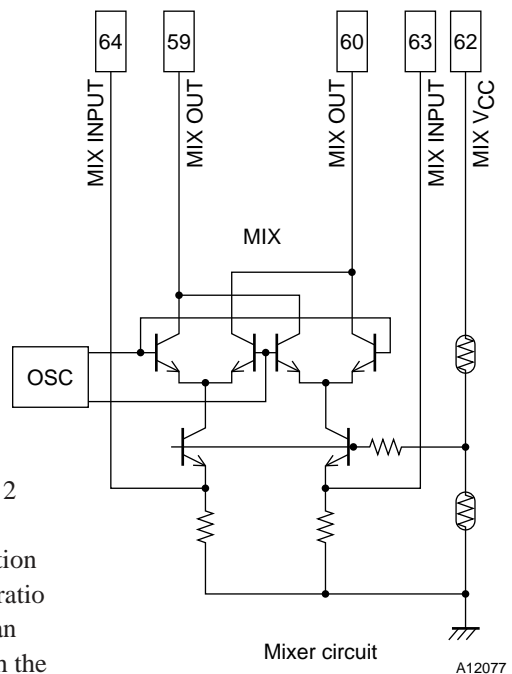
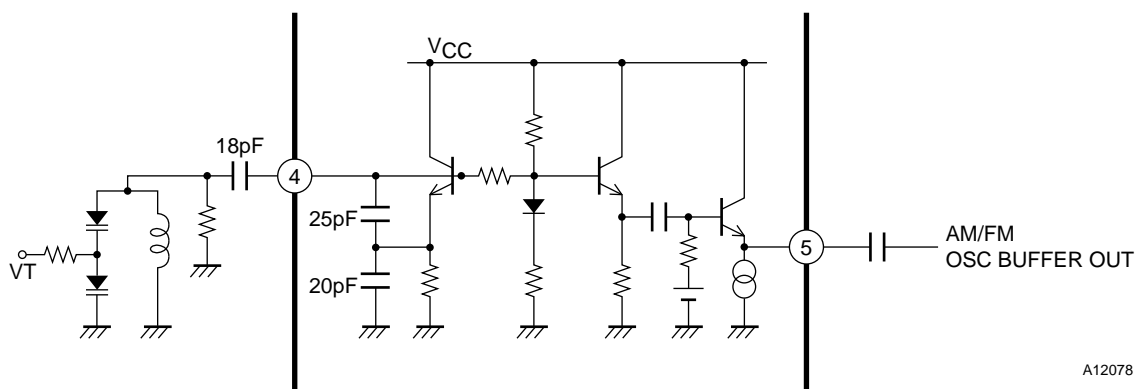

Fig. 10

- Oscillator

Figure 11 shows the type of oscillator circuit used in this IC. It includes both an oscillator and an oscillator buffer.



A12078

Fig. 11

- Figure 12 shows the type of FM first IF amplifier used in this IC. It is a differential single-stage amplifier.

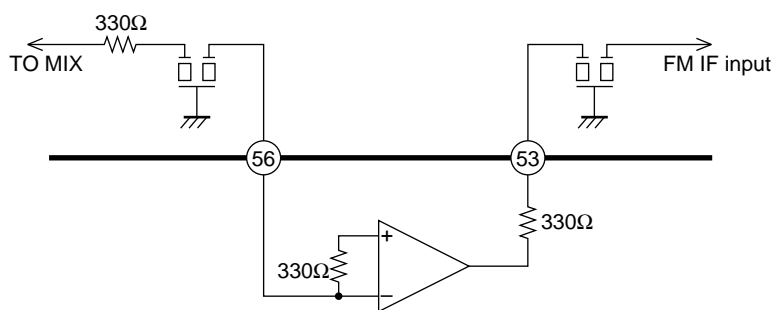

A12079

Fig. 12

Specifications

Input impedance: 330 Ω

Output impedance: 330 Ω

Gain: 20 dB

2. FM IF

- Notes on the FM SD and SD adjustment

The figure below presents an overview of the FM SD and the IF count buffer.

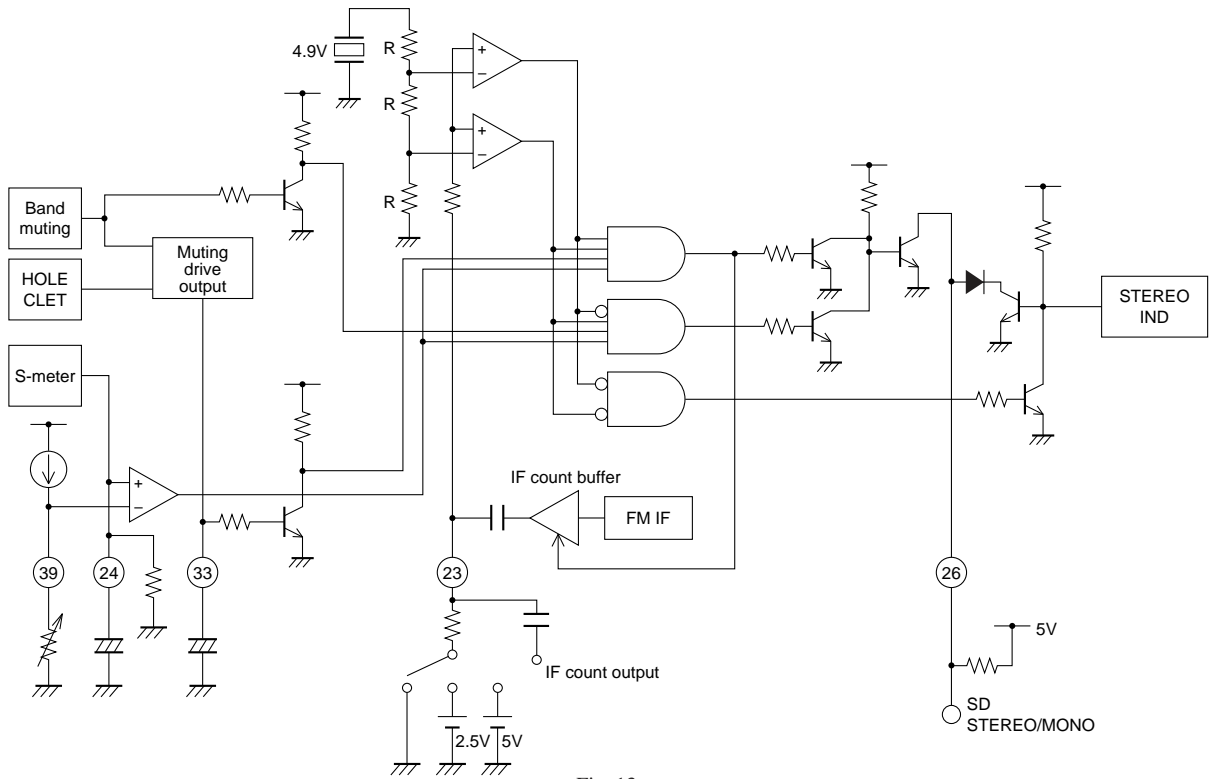
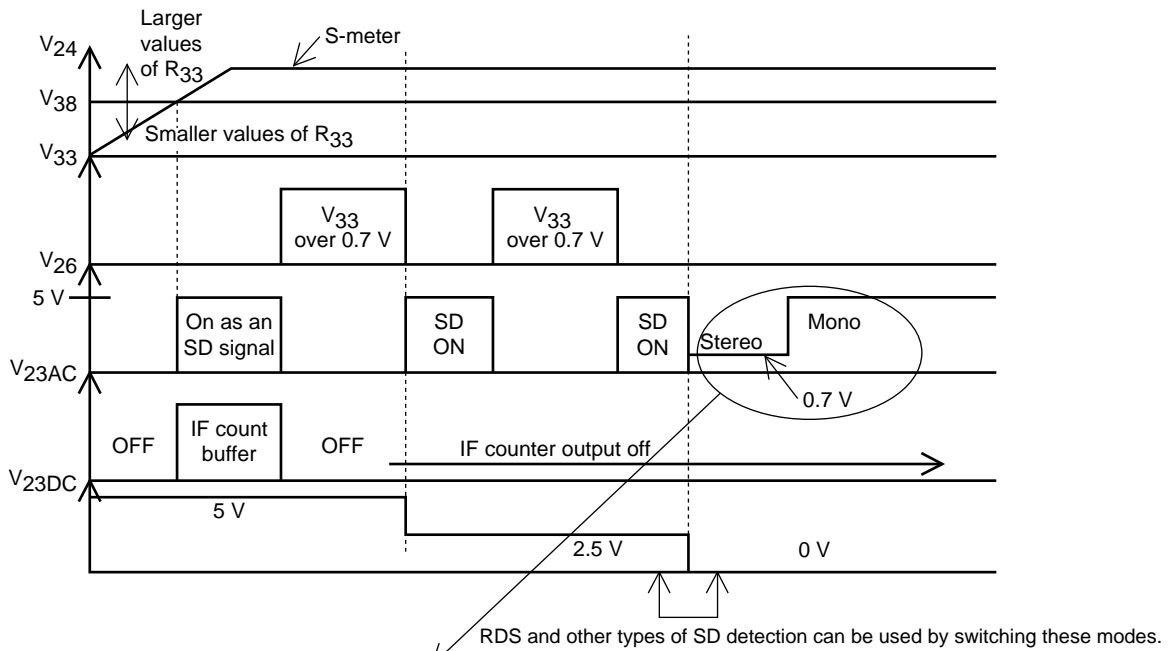

Fig. 13

A11759

Figure 14 shows the relationship between the FM SD, the IF count buffer output, the S-meter, and the muting drive output.



New LA1784M functionality: For stereo input (when the V26 pin voltage is 0.7 V), when this pin is shorted to ground (0.1 V or lower) the IC will operate in forced mono mode.

A11758

Fig. 14

• Transient response characteristics during automatic tuning

The transient characteristics for SD and IF count buffer on/off operation are determined by the time constants of the RC circuits attached to the following pins.

- (1) Muting time constant: pin 33
- (2) S-meter time constant: pin 24
- (3) AFC time constant: pin 34

There are two points that require consideration when using fast tuning.

(1) The SD time constant due to the S-meter time constant

Since the current I24 (pin 24) varies with the field strength, the time constant also changes. There is no hysteresis in the comparator.

If a smaller value is used for C24, you must select a value for C such that the AGC does not become unstable when the pin 24 voltage is used for keyed AGC.

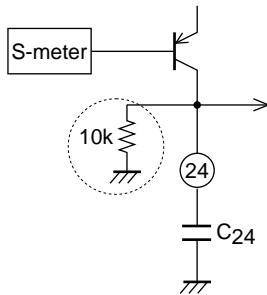
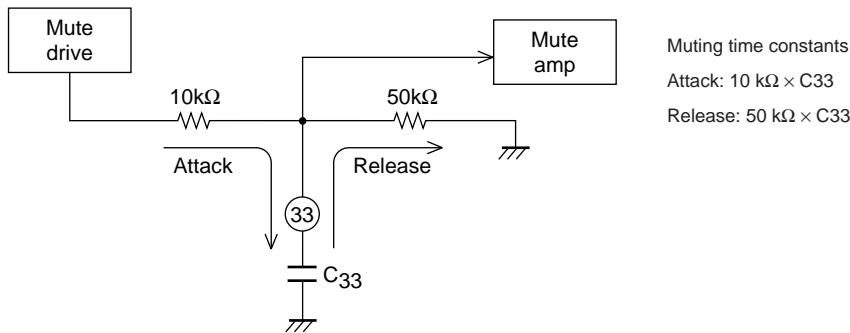

Fig. 15

A12080

(2) The SD time constant due to the pin 33 muting voltage time constant

The changes in volume due to field fluctuation during weak field reception can be made smoother by setting the attack and release times during soft muting operation.



Muting time constants  
 Attack:  $10\text{ k}\Omega \times C33$   
 Release:  $50\text{ k}\Omega \times C33$

Fig. 16

A11766

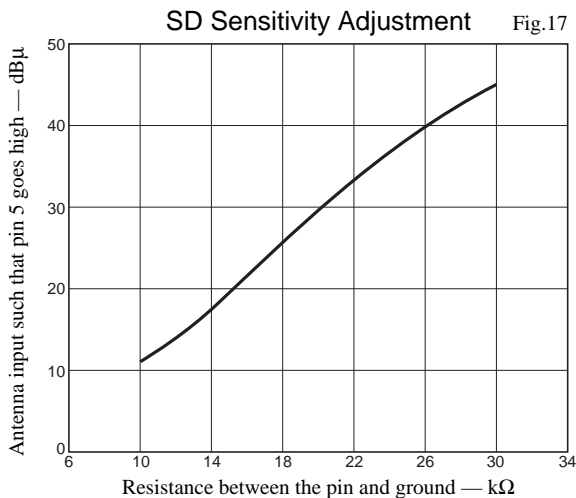



However, when testing this stop sensitivity, note that when checking the waveform on the IF count buffer output (pin 23), there are cases, such as that shown below, where current in the test system may be seen as flowing to ground and cause oscillation that causes the IF count buffer output to go to the output state.

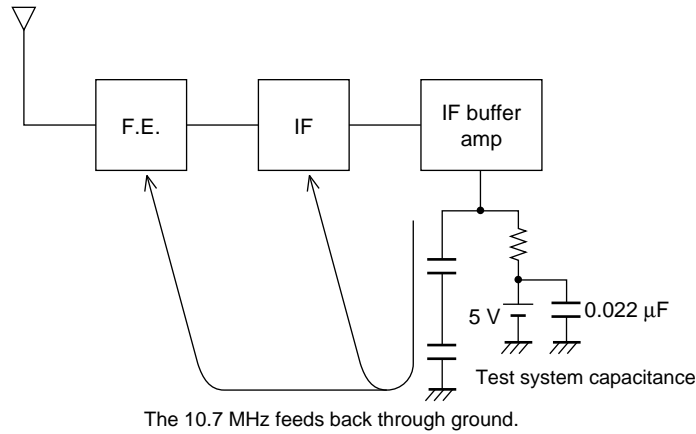

Fig. 18

A12081

- FM Muting control pin (pin 47) (R47: 30 kΩ variable resistor)  
The -3 dB limiting sensitivity can be adjusted with R47.

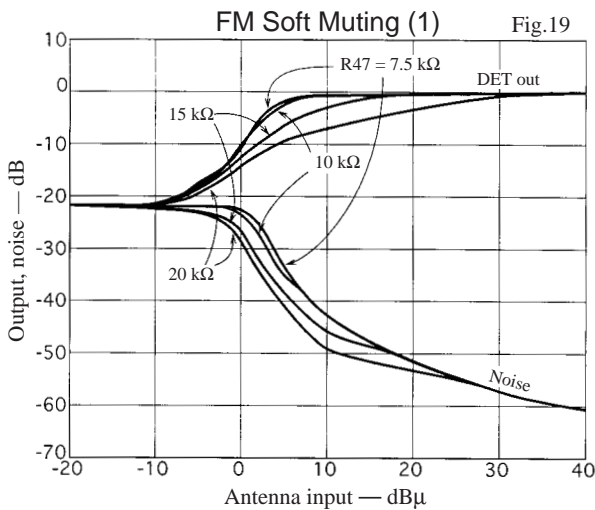
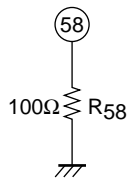

Fig.19

- FM muting attenuation adjustment (pin 58)  
The muting attenuation can be switched between the three levels of -20, -30, and -40 dB by the resistor inserted between pin 58 and ground. (Note that the exact values depend on the total tuner gain.)  
The noise convergence with no input is determined by the pin 58 voltage.



A11764

R58	Mute ATT
Open	-20 dB
200 kΩ	-30 dB
30 kΩ	-40 dB

The attenuation can be set by making R33 smaller as listed in the table above.

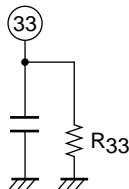

A11765

Fig. 20

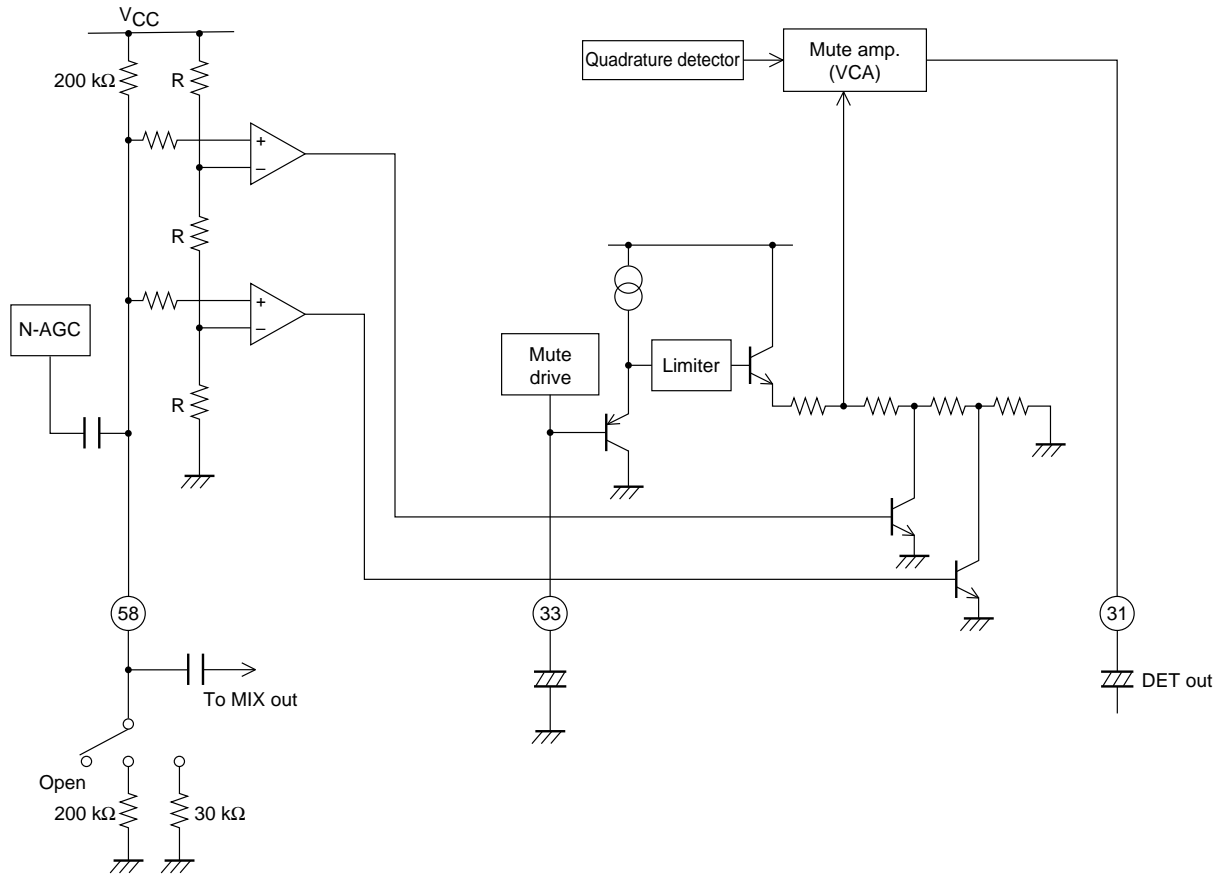
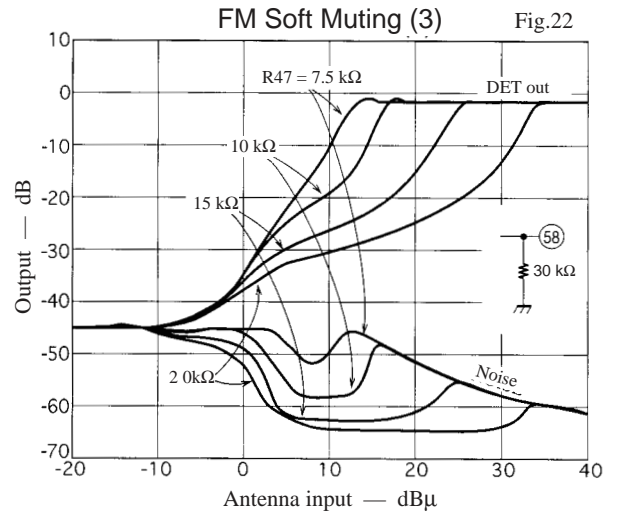
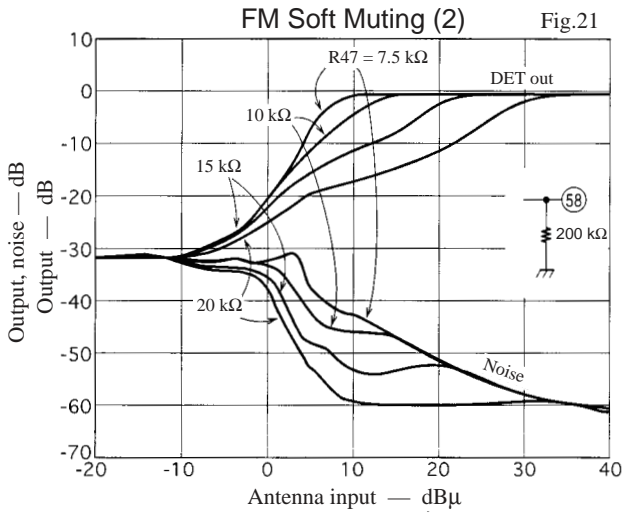

Fig. 23

A11767

- FM muting off function  
Forcing this pin to the ground level turns muting off.

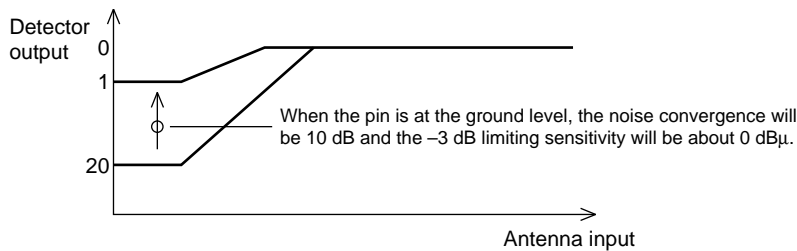

Fig. 24

A12082

• Hall detection

The Hall detection function detects the level of the pin 36 quadrature input signal and then applies peak detection to that result. The result is output from pin 33. This circuit has three effects.

- (1) It assures that muting will be applied for weak inputs with an antenna input of under 5 dBμ. The amount of attenuation is referenced to an antenna input of 60 dBμ, fm = 1 kHz, and a 22.5 kHz dev output, and is variable from 10 dB to 40 dB when there is no input. Thus one feature of this circuit is that the weak input noise attenuation and the -3 dB limiting sensitivity for over 5 dBμ inputs can be set independently.

Hall Detection Output — Antenna Input Characteristics Fig.25

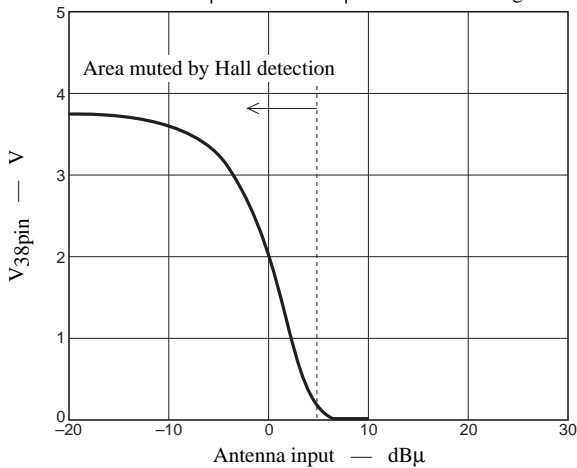

- (2) When the pin 36 quadrature input is a saturated input, the pin 36 noise level ( $V_a$ ) is detected and a peak-hold function is applied to pin 33 ( $V_b$ ) for locations rapid field strength variations and severe multipath occurs for fields that result in an antenna input level of over 5 dBμ.

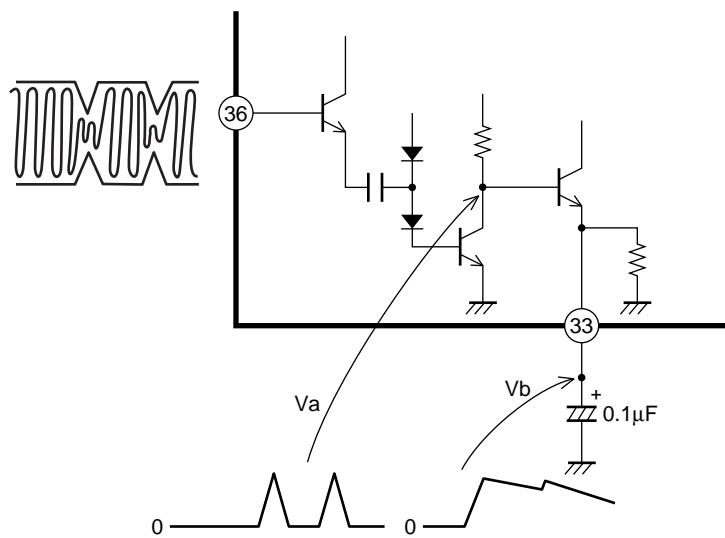
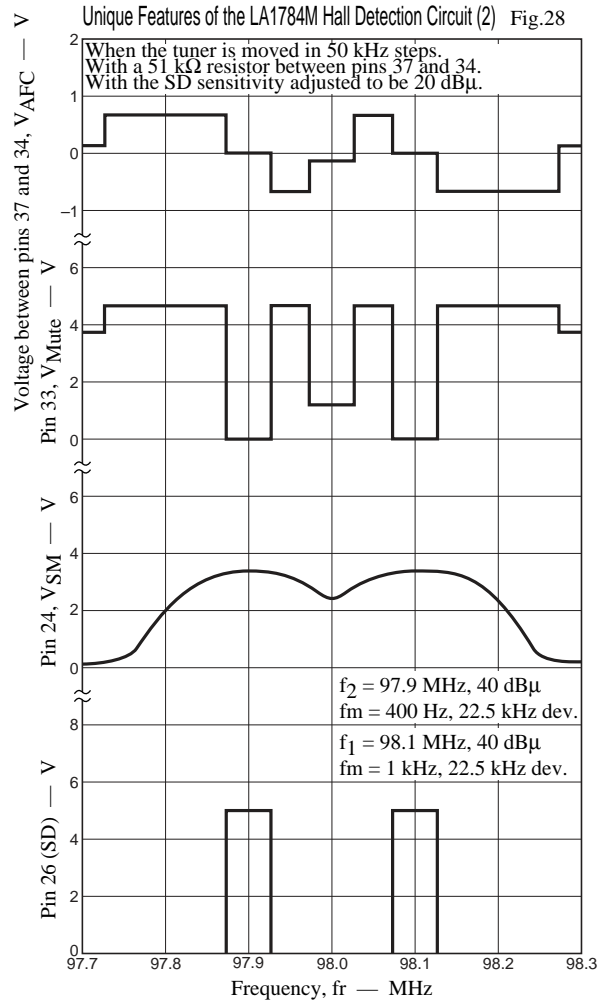
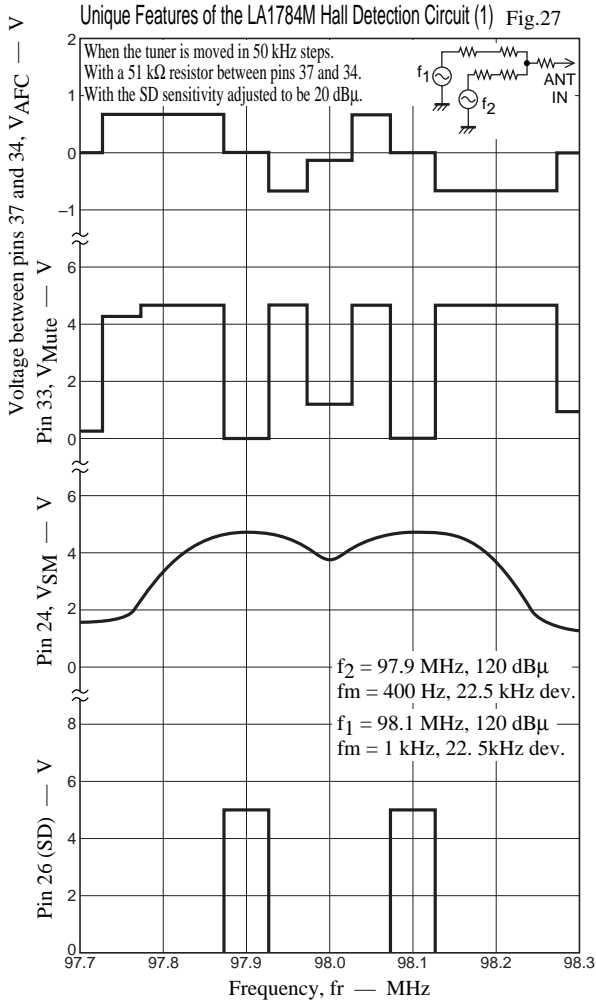

Fig. 26

A12083

(3) Unique features

One unique feature of the LA1784M is that if there are adjacent stations such that  $f_1 = 98.1$  MHz and  $f_2 = 97.9$  MHz, a search operation will not stop at 98.0 MHz. Since  $V_{AFC} = 0$  V and  $V_{SM} = 3.6$  V at 98.0 MHz in the situations shown in figure 27 and 28, even though Hall detection would normally not operate and SD would be high, in this IC the Hall detection circuit will operate,  $V_{Mute}$  will be set to 1.2 V (over 0.7 V) and the SD signal will go low, thus preventing incorrect stopping of the search.



• Notes on the quadrature input level

When a strong field is being received the quadrature signal input (pin 36) requires a 200 mV rms input, and the detection transformer and the damping resistor between pins 36 and 37 must be designed.

(We recommend the Sumida SA-208 transformer and a 10 kΩ resistor between pins 36 and 37.)

When the pin 36 input level falls below 160 mV rms, the Hall detection circuit operates and the pin 33 mute drive output voltage increases. Therefore, when pin 36 input is from 160 to under 200 mV rms during strong field reception, the muting circuit may or may not operate due to sample-to-sample variations between individual ICs. Furthermore, the SD function may not operate, and the audio output level may be reduced. Incorrect operation due to sample-to-sample variations and temperature characteristics can be prevented by keeping the pin 36 voltage at 200 mVrms or higher.

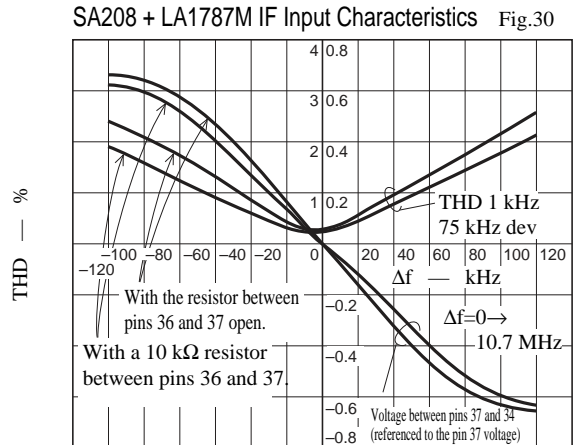
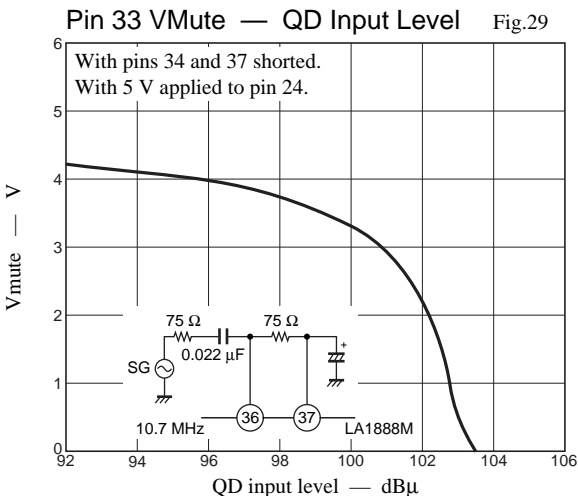

R <sub>36-37</sub>	Detector output MPX OUT V <sub>o</sub>	Pin 36 AC level QDIN
Open	330 mVrms	235 mVrms
10 kΩ	280 mVrms	200 mVrms

• Band Muting Adjustment Procedure

The muting bandwidth can be modified as shown in figure 31 with the resistor R<sub>BW</sub> between pin 34 and 37.

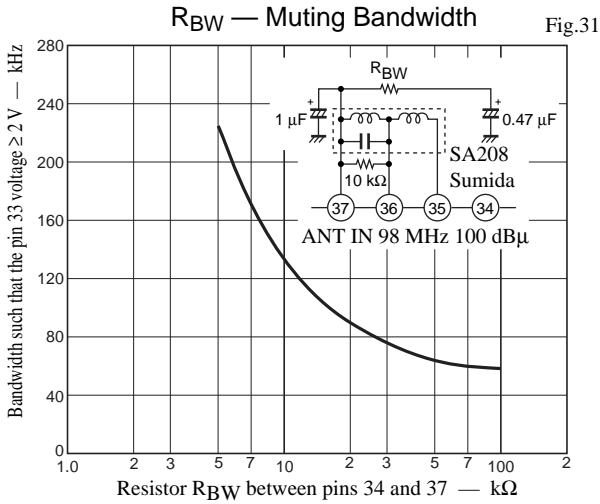

3. AM

• AM AGC system

The LA1787M RF AGC circuit takes its input from three sources: the WIDE AGC pin (pin 46), the MIDDLE AGC pin (pin 49) and NARROW AGC. There is also an IF AGC circuit.

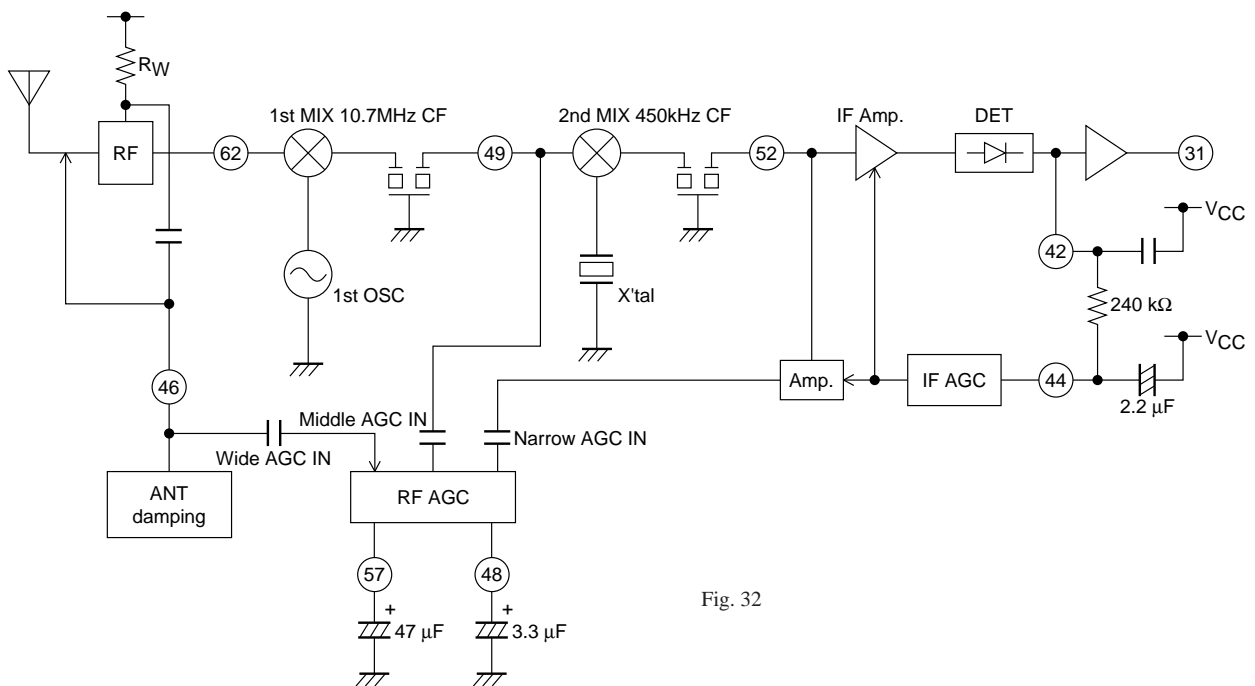
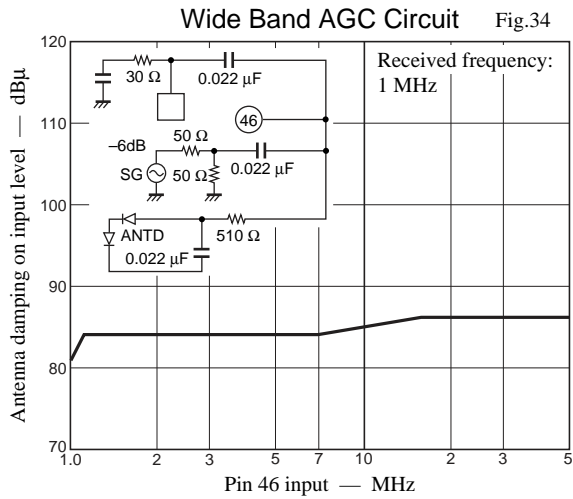
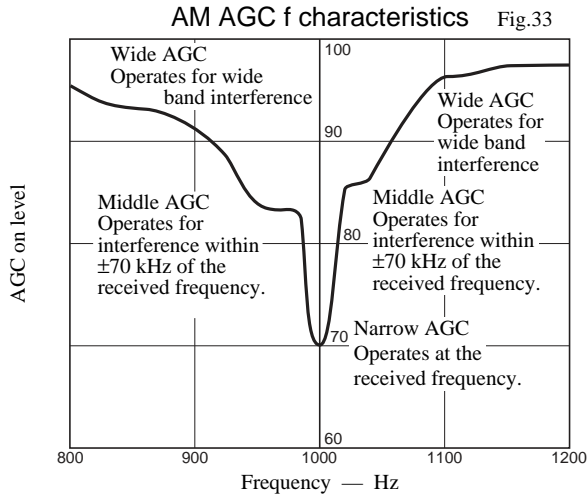

Fig. 32



The wide band AGC circuit in this IC has the frequency characteristics shown above. The pin 46 input frequency characteristics are identical to those of the RF amplifier gate. This AGC circuit serves to prevent distortion at the FET input when a strong signal is applied to the antenna circuit. The level at which the AGC circuit turns on can be adjusted to an arbitrary level with the wide band AGC adjustment resistor. A delayed AGC on level can be handled by reducing the value of the adjustment resistor.

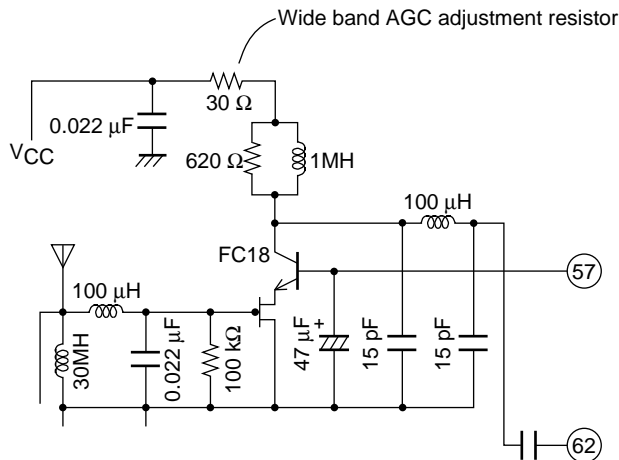

Fig. 35

A12084

- Notes on AM SD (pin 26) and the SD adjustment pin  
SD and the IF buffer are operated by comparing the S-meter level (V24) and the 5 V reference voltage as shown in figure 36.

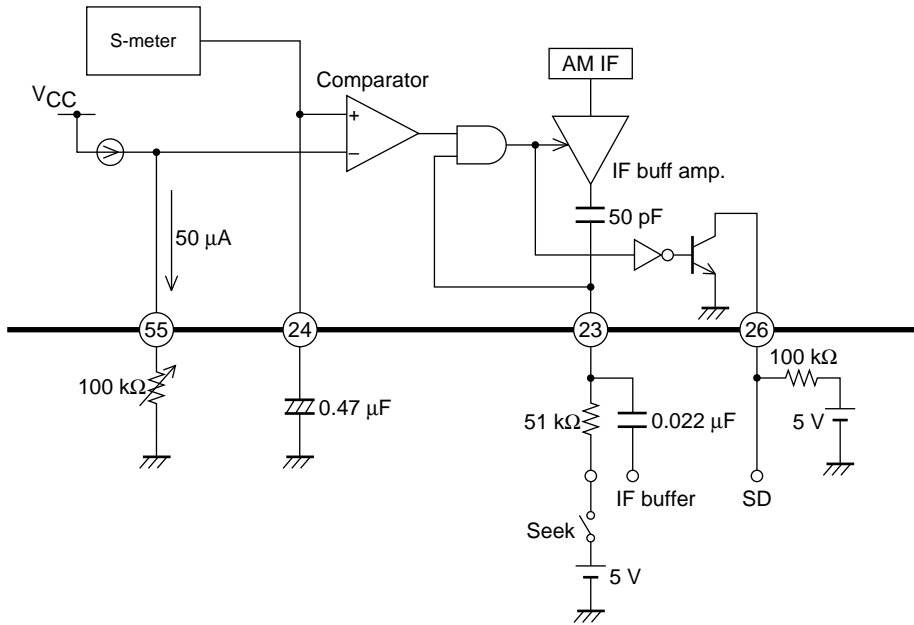

Fig. 36

A12085

Figure 37 shows the relationship between the AM SD, the IF count buffer, and the S-meter.

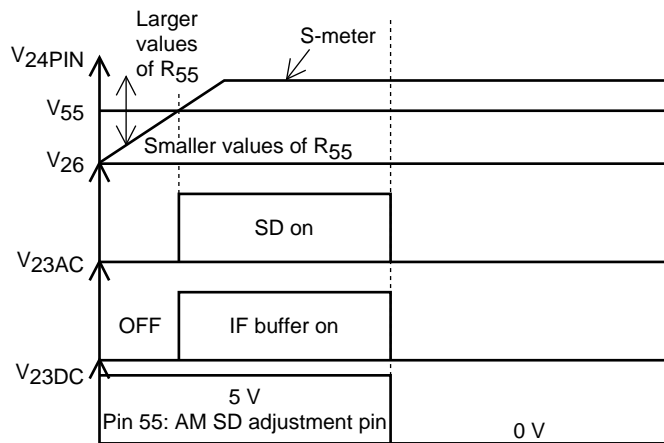

Fig. 37

A11760

LA1787M

- AM high band cut and detector output level adjustment methods

The pin 31 AM and FM tuner output has an impedance of 10 kΩ in AM mode and a few tens of Ohms in FM mode. Therefore, R31 is used to lower the AM detector output level and C31 determines the AM high band frequency characteristics.

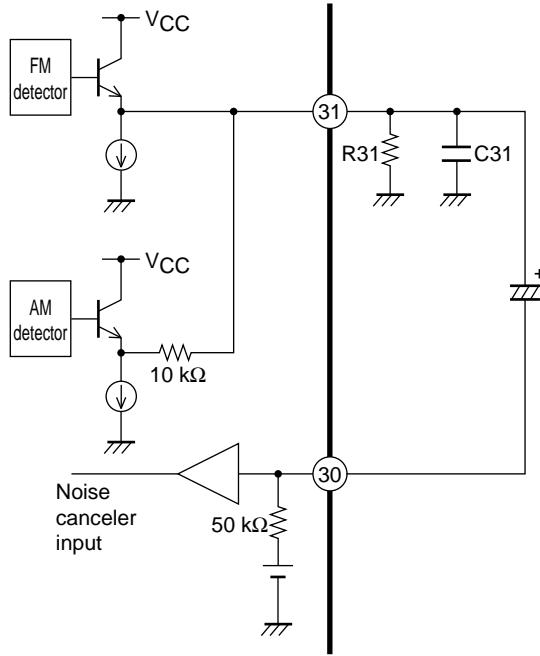

A12086

Fig. 39

- AM stereo system pins

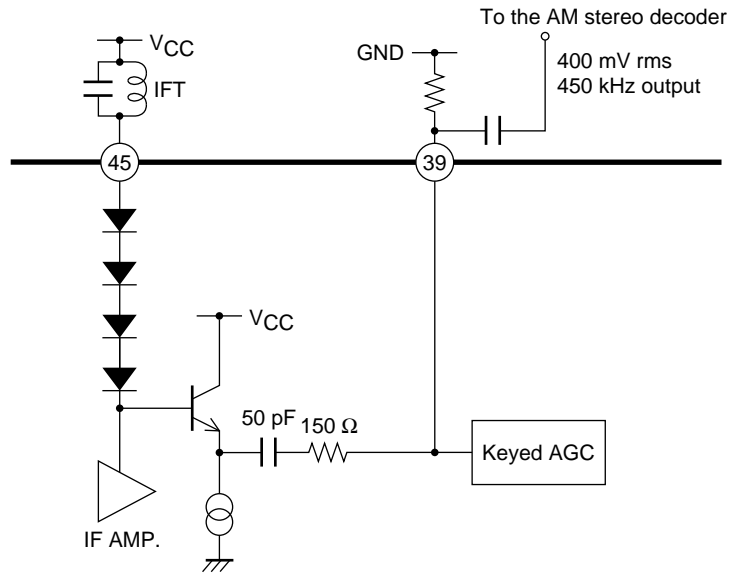

Fig. 40

A11761



• AM low band cut adjustment method

The AM low band frequency characteristics can be adjusted with C42, which is inserted between pin 42 and  $V_{CC}$ . Since the detector is designed with  $V_{CC}$  as the reference, C42 must be connected to  $V_{CC}$ .

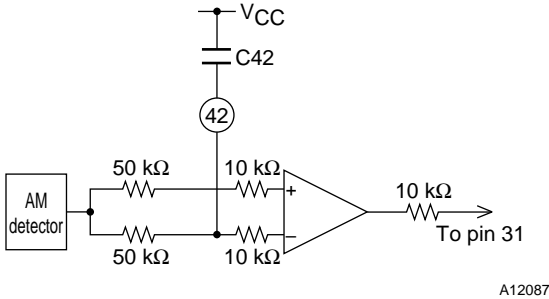
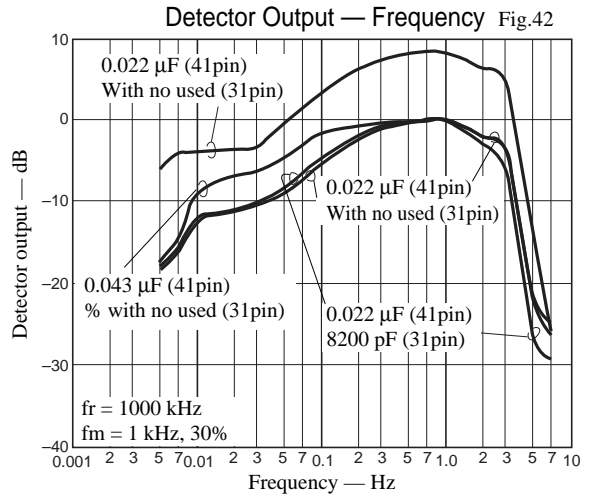

Fig. 41



4. Noise Canceler Block

- The noise canceler input (pin 30) has an input impedance of about 50 kΩ. Check the low band frequency characteristics carefully when determining the value of the coupling capacitor used. Note that  $f_C$  will be about 3 Hz when a 1 μF capacitor is used in the application.
- Pins 8 and 9 are used to set the noise detector sensitivity and the noise AGC. It is advisable to first set the noise sensitivity for a medium field (an antenna input of about 50 dBμ) with pin 8 (the noise sensitivity setting pin), and then set the AGC level for a weak field (20 to 30 dBμ) with pin 9 (the AGC adjustment pin). If the noise sensitivity is increased, the AGC will become more effective but, inversely, the weak field sensitivity will be reduced.

Noise canceler 10 kHz overmodulation malfunction may be a problem. In particular, when an overmodulated signal is input, the noise canceler may, in rare cases, malfunction. This is due to the fact that the IF detector output has a waveform of the type shown in figure 43 due to the bands of the IF ceramic filters as shown below. (Here, the antenna input is 60 dBμ, the ceramic filters are 150 kHz × 1 and 180 kHz × 2,  $f = 10$  kHz, 180 kHz dev.) The noise canceler reacts to the spikes (whiskers) generated due to this overmodulation, which results in distortion to the audio output. (The spike components due to overmodulation occur due to the bands of the ceramic filters in the tuner.) The following describes a method for resolving this problem. This incorrect operation due to overmodulation is prevented by removing the spike components due to this overmodulation with a low-pass filter consisting of a 1 kΩ resistor and a 2200 pF capacitor shown in figure 44. However, note that the FM separation characteristics in the high band and the AM frequency characteristics will change.

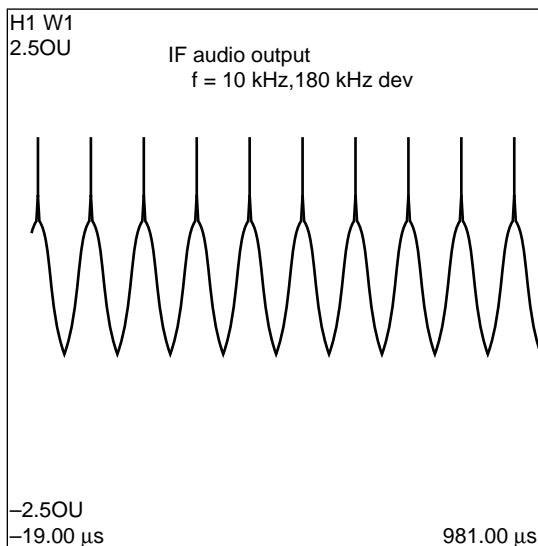

Fig. 43

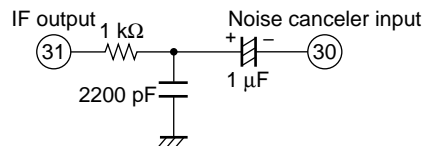

Fig. 44

A12089

A12088

5. Multiplexer Block

- HCC (high cut control) frequency characteristics (pin 41)

When the HCC function operates, the frequency characteristics of the output signal are determined by the capacitance of the external capacitor connected to pin 41.

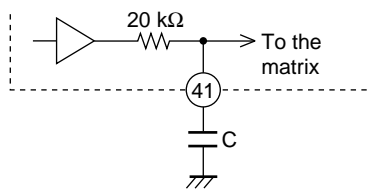

Fig. 45

A12090

$$f_C = \frac{1}{2\pi \times C \times 20 \text{ k}\Omega} \text{ [Hz]}$$

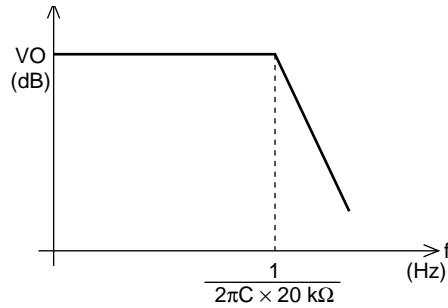

Fig. 46

A12091

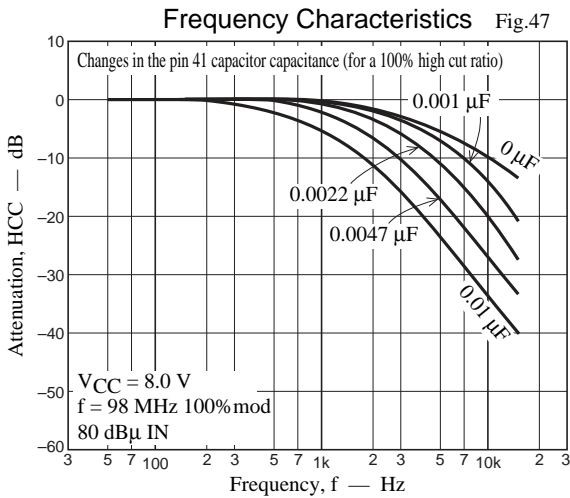

Fig.47

- Pilot canceler adjustment (pins 17 and 18)

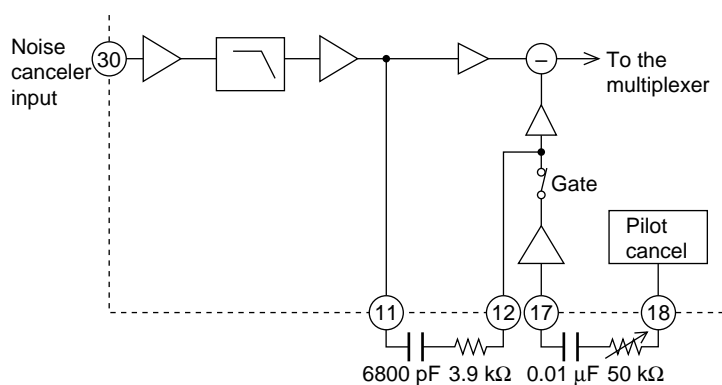
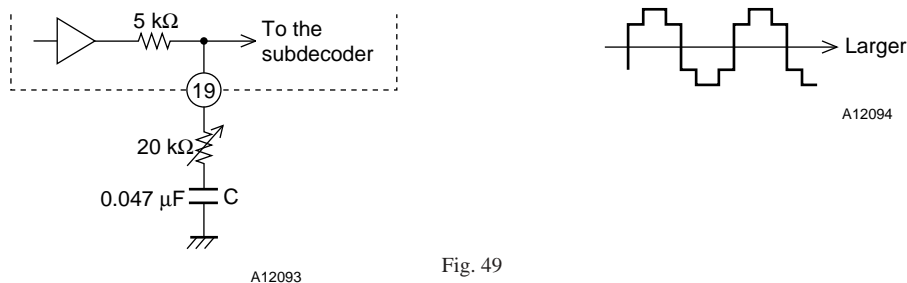

Fig. 48

A12092

The pilot canceler signal waveform (pin 19) is a 19 kHz signal that contains no third harmonic as shown in figure 48. Since this signal has the same phase as the pilot signal, no capacitor is required between pin 18 and ground. Since it has no third harmonic component, excellent pilot cancellation can be acquired in both the left and right channels by adjusting with a variable resistor.

- Separation adjustment (pin 19)



The separation is adjusted by modifying the input level to the subdecoder with the variable resistor connected to pin 19. Since only the sub-modulation level is changed by changing the variable resistor setting, the monaural (main) output level is not changed. Furthermore, degradation of high band separation in the decoder can be avoided if the impedance of the external capacitor (C) in the subchannel frequency band (23 to 53 kHz) is made sufficiently smaller than the variable resistor.

### 6. MRC Circuit

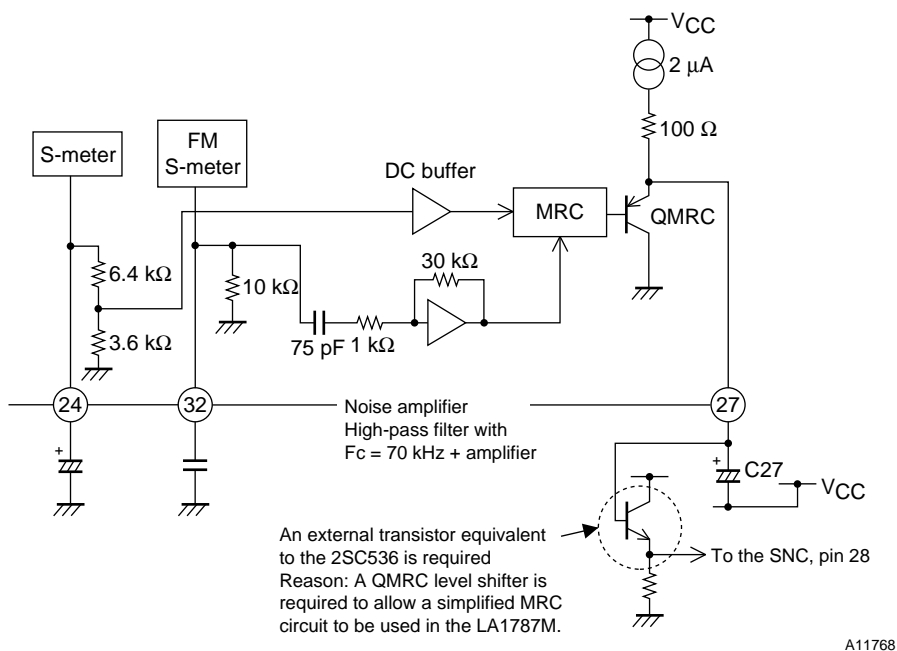

Fig. 50

(1) When there is no AC noise on pin 32

$$V_{24} = V_{27} - V_{BE}$$

↑  
Q<sub>MRC</sub>

V<sub>27</sub> is about 2.5 V when the antenna input is 60 dB or higher.

(2) Since the MRC noise amplifier gain is fixed, the MRC circuit is adjusted by reducing the AC input level.



Fig. 51

A11769

(3) The MRC attack and release are determined by C27 on pin 27.

Attack:  $7 \mu\text{A} \cdot C27 \rightarrow 2 \mu\text{A} \cdot C27$

Release:  $500 \Omega \cdot C27 \rightarrow 100 \Omega$

#### Notes on the Noise Canceler

The noise canceler characteristics have been improved by implementing the circuit that determines the gate time in logic. Since the time constant in earlier noise cancelers was determined by an RC circuit such as that shown in figure 52, the rise time shown in figure 53 was influenced by the values of the resistor and capacitor used. As a result the noise exclusion efficiency was reduced by this delay in the rise time. In the LA1787M, this rise time was shortened by implementing the circuit that determines the gate time in logic, allowing it to reliably exclude noise.

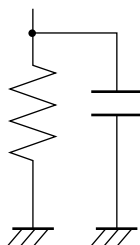

Fig. 52

A11771

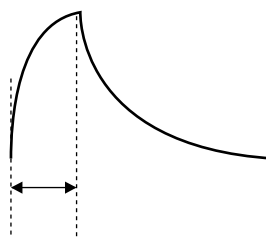

Fig. 53

A11772

Gain Distribution (FM)

This section investigates the gain in each block in the LA1787M when the Sanyo recommended circuits are used.

(Test conditions)

Ambient temperature: 26°C

Antenna and mixer input frequency: 98.1 MHz

First and second IF input frequency: 10.7 MHz

The input levels when  $V_{SM} = 2\text{ V}$  will be as follows.

ANT IN: 19 dB $\mu$

MIX IN: 30 dB $\mu$

1st IF IN: 42 dB $\mu$

2nd IF IN: 60 dB $\mu$

When the gains for each block are determined according to the above, the results are as follows.

RF GAIN: 11 dB

MIX GAIN: 12 dB

1st IF GAIN: 18 dB

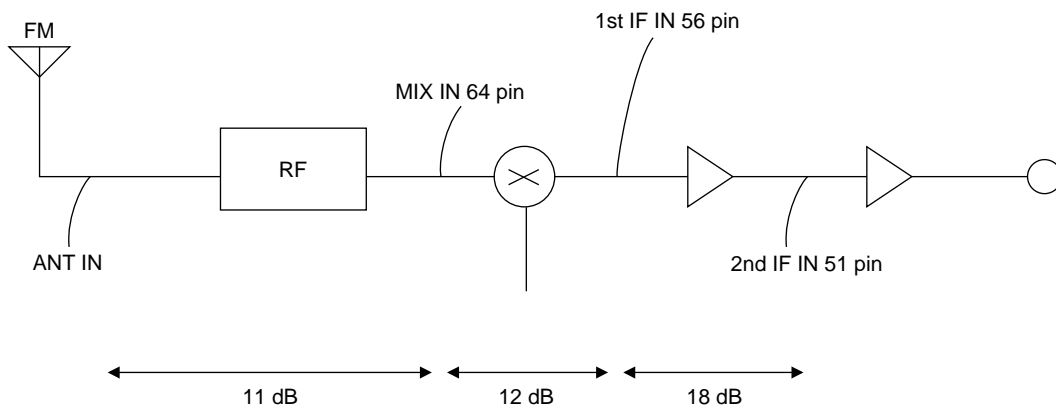

A11773

Fig. 54

(AM)

This section investigates the gain in each block in the LA1787M when the Sanyo recommended circuits are used.

(Test conditions)

Ambient temperature: 26°C

Antenna and mixer input frequency: 1 MHz

First and second mixer input frequency: 10.7 MHz

Second IF input frequency: 450 kHz

The gains at each stage will be as follows.

RF Gain (ANT IN-pin62): 17 dB

1st MIX Gain (pin62-pin56): 8 dB

1st IF Gain (pin55-pin53): 15 dB

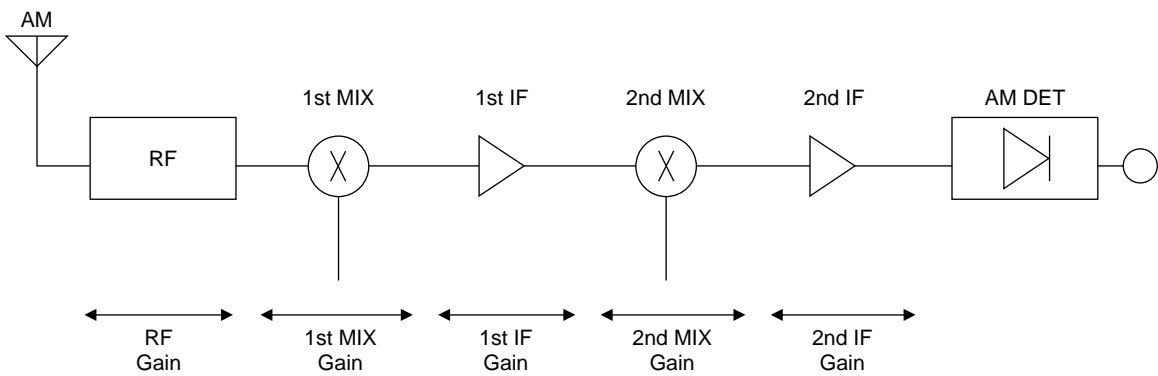

A11774

Fig. 55

Input Circuits for Each Stage

[FM]

• Mixer input

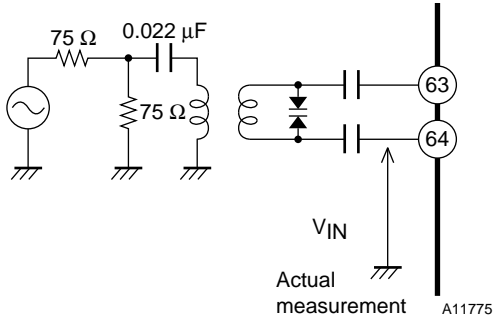

• First IF input

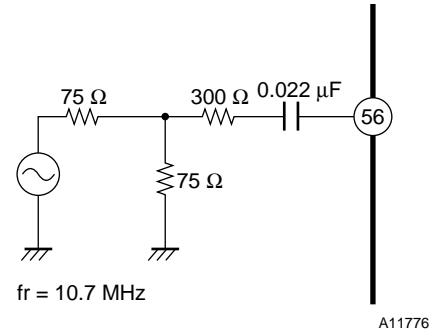

• IF input

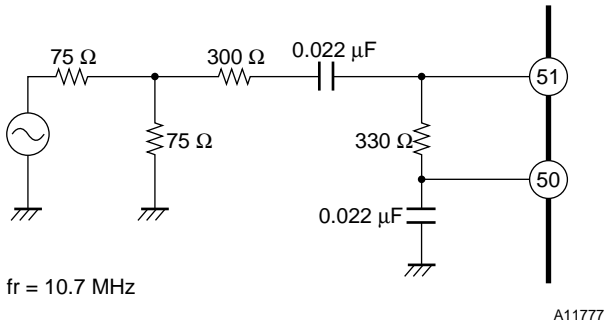

[AM]

• First mixer input

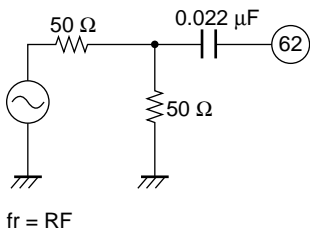

• Second mixer input

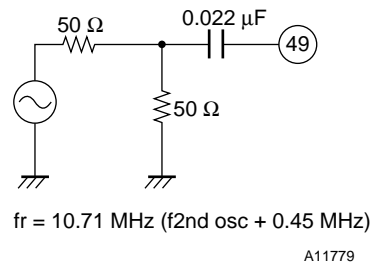

• IF input

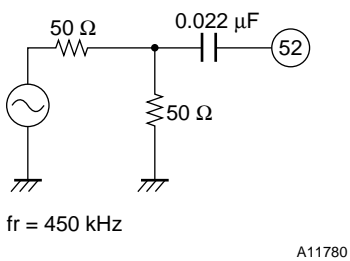

• Del input

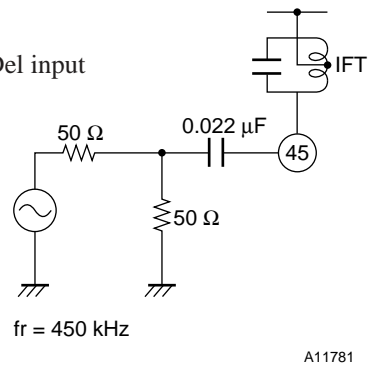

Sample AM tuner Circuit with the LC72144 Used Together

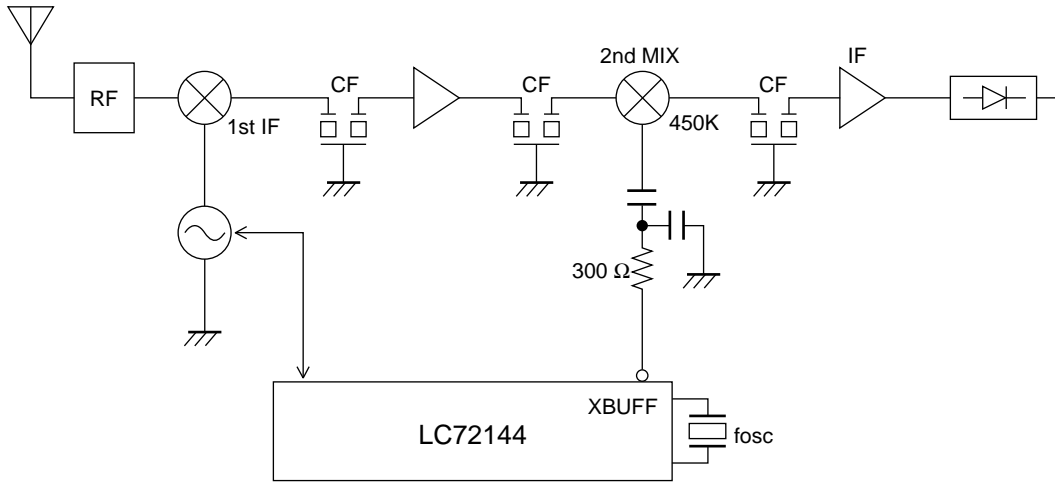

A11782

		AM 1st IF	Step	FM IF
1	f <sub>osc</sub> 10.25 MHz	10.7 MHz	10 kHz, 11 kHz	10.7 MHz
2	f <sub>osc</sub> 10.35 MHz	10.8 MHz	9 kHz, 10 kHz	10.8 MHz

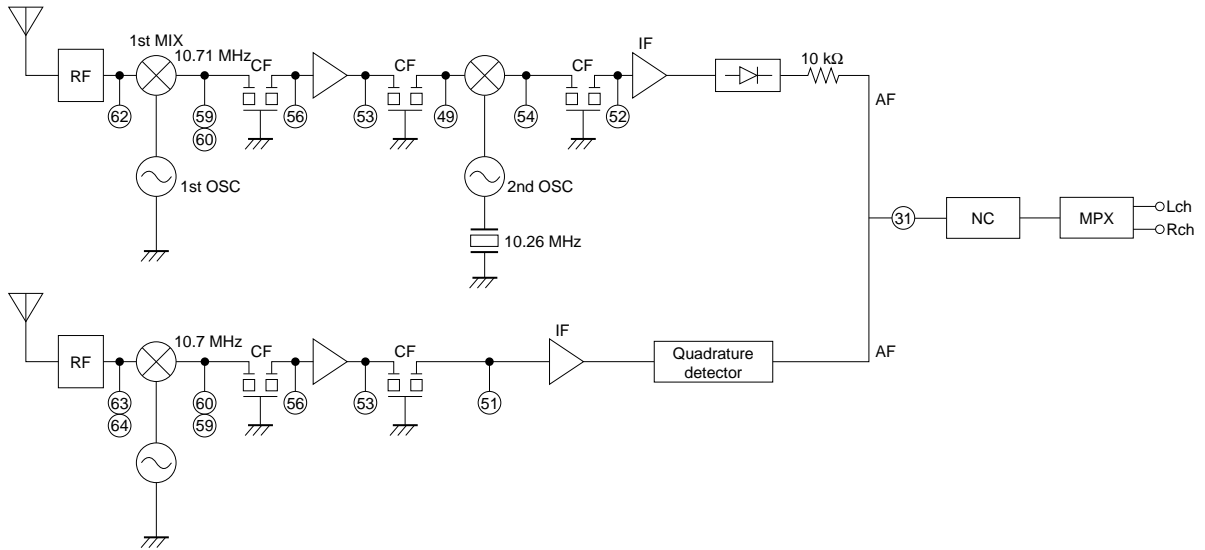

A11783



**Crystal Oscillator Element**

Kinseki, Ltd.

Frequency: 10.26 MHz

CL: 20 pF

Model No.: HC-49/U-S

**Coil Specifications**

Sumida Electronics, Ltd.

[AM Block]

AM FILTEER (SA-1051)

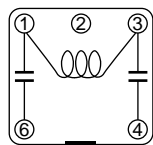

AM OSC (SA-359)

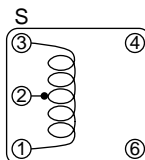

AM IF1 (SA-264)

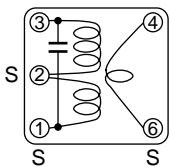

AM IF2 (SA-1063)

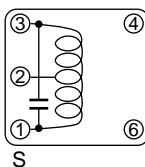

AM loading (SA-1062)

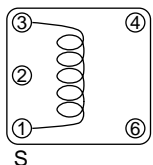

AM ANT IN (SA-1048)

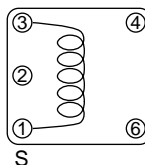

AM RF amplifier (RC875-222J)

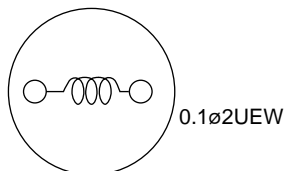

[FM Block]

FM RF (SA-1060)

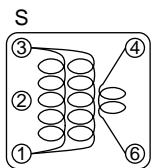

FM ANT (SA-1061)

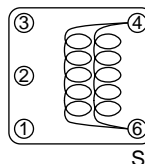

FM OSC (SA-1052)

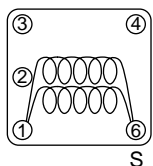

FM MIX (SA-266)

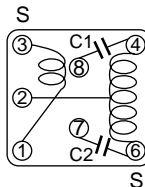

FM DET (SA-208)

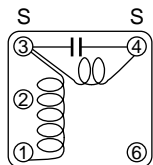

The Toko Electric Corporation

[AM Block]

AM FILTEER (A2861BIS-15327)

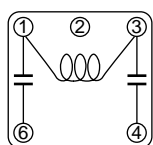

AM OSC (V666SNS-214BY)

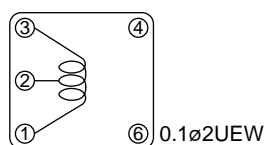

AM IF1 (7PSGTC-5001A)

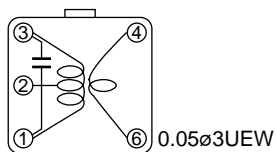

AM IF2 (7PSGTC-5002Y)

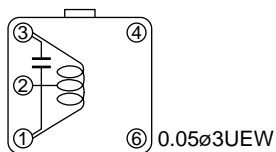

AM loading (269ANS-0720Z)

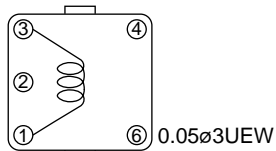

AM ANT IN (385BNS-027Z)

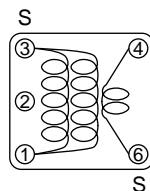

AM RF amplifier (187LY-222)

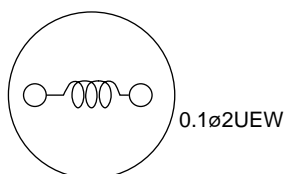

[FM Block]

FM RF (V666SNS-208AQ)

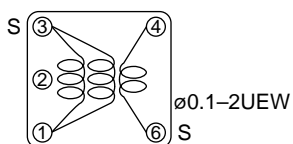

FM ANT (V666SNS-209BS)

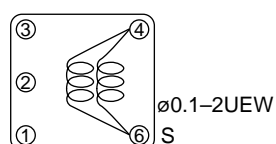

FM OSC (V666SNS-205APZ)

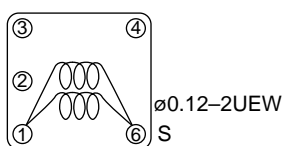

FM MIX (371DH-1108FYH)

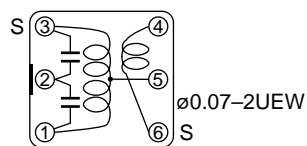

FM DET (DM600DEAS-8407GLF)

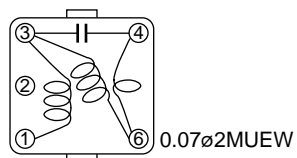

**Coil Specifications**

Sagami Elec Co., Ltd.

[AM Block]

AM FILTEER (000021055)

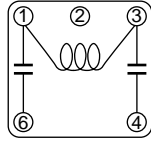

AM OSC (000021056)

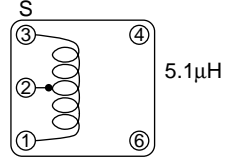

AM IF1 (000021057)

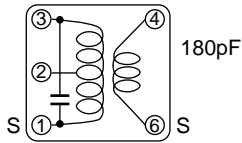

AM IF2 (000021059)

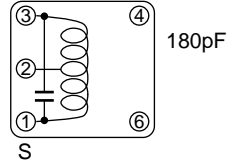

AM loading (000021061)

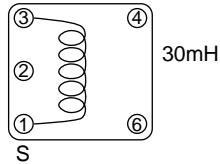

AM ANT IN (000021062)

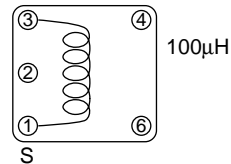

AM RF amplifier (000021063)

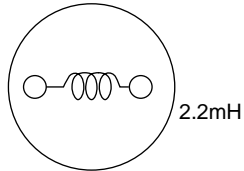

[FM Block]

FM RF (000021064)

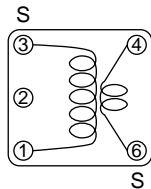

FM ANT (000021065)

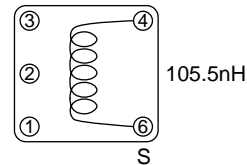

FM OSC (000021066)

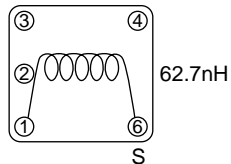

FM MIX (000021067)

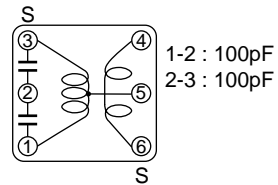

FM DET (010021075)

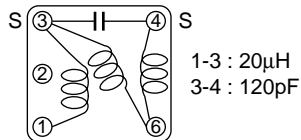

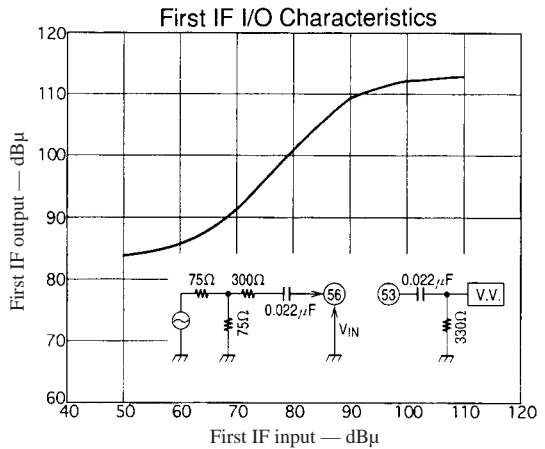
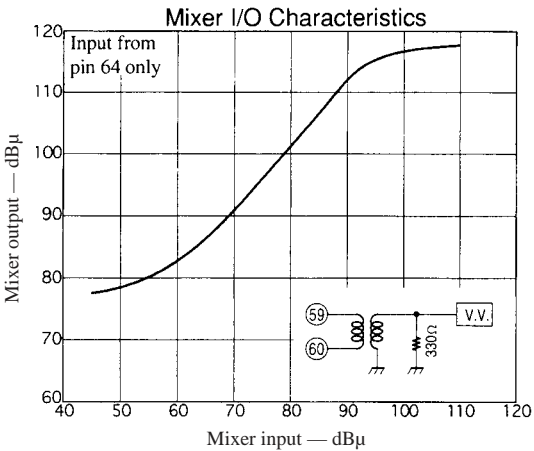
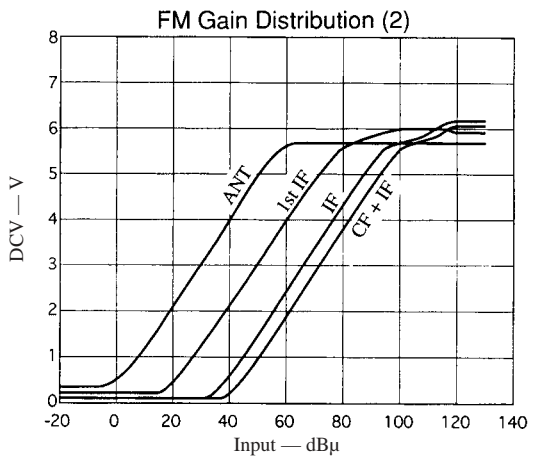
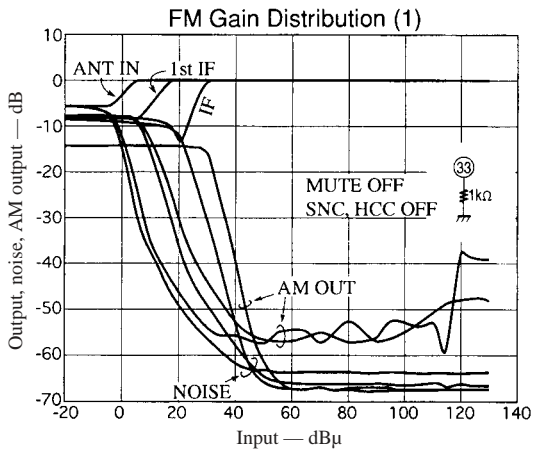
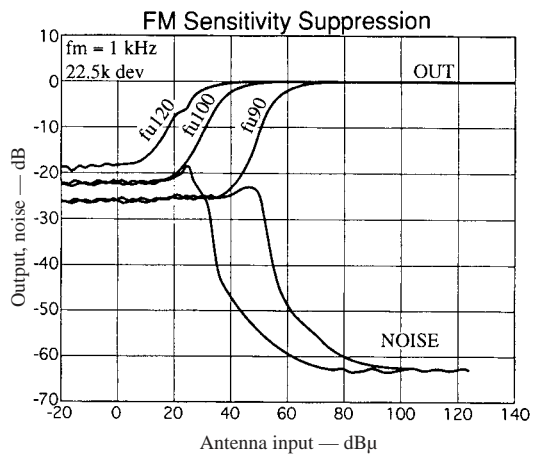
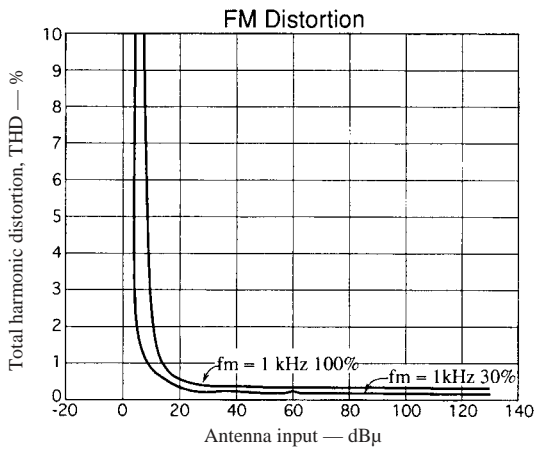
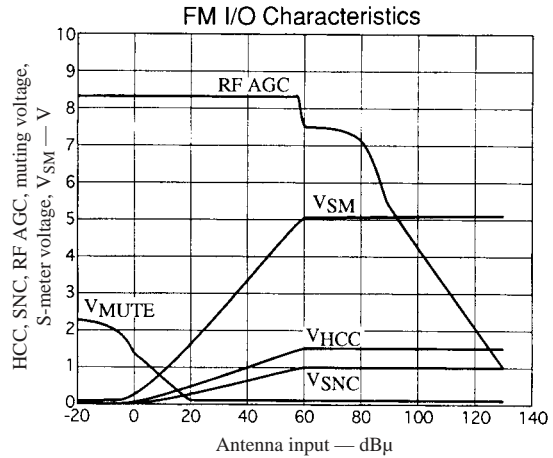
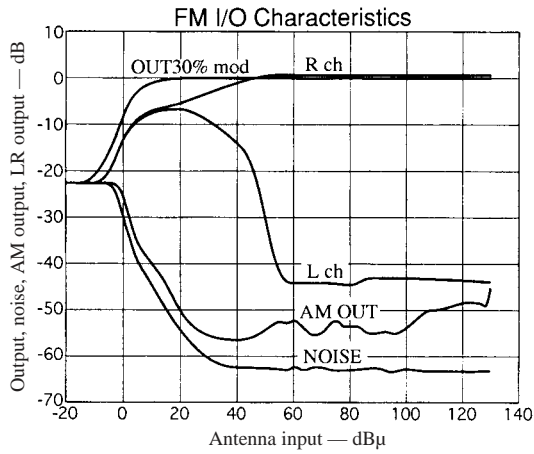

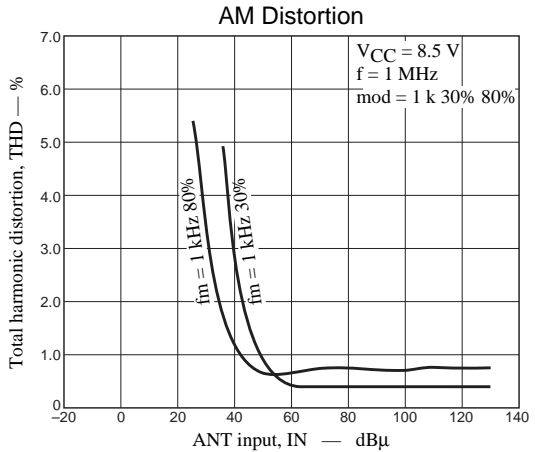
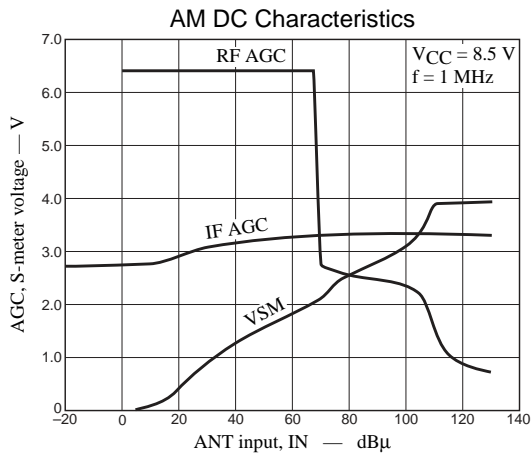
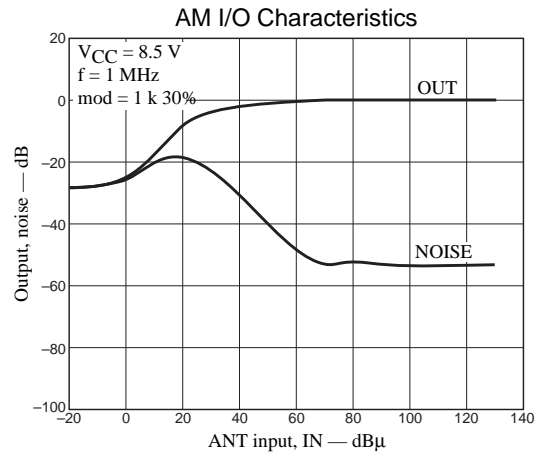
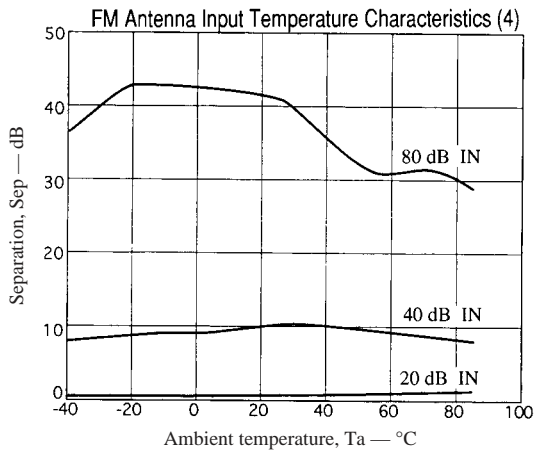
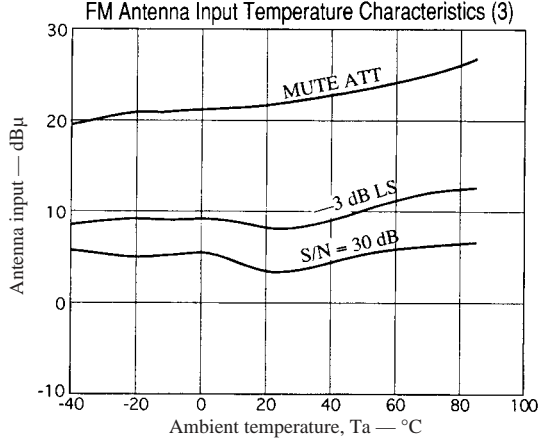
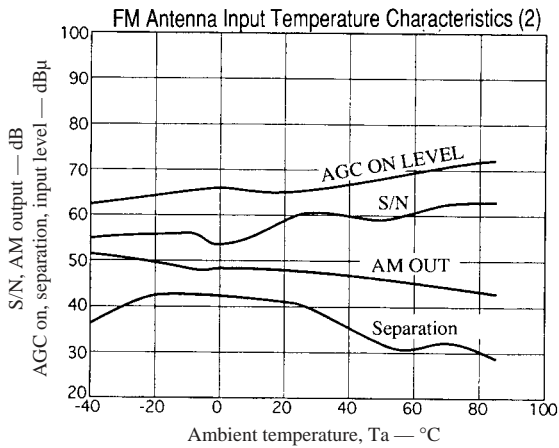
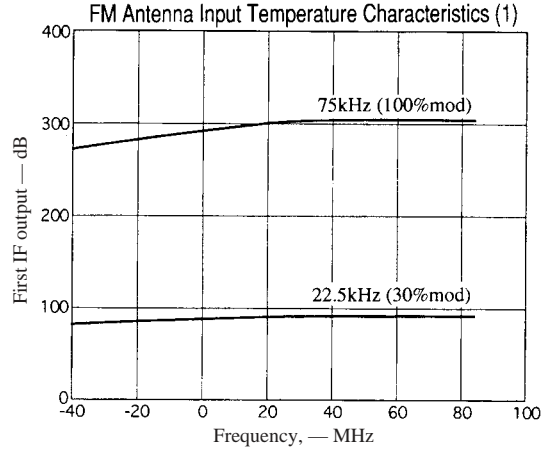
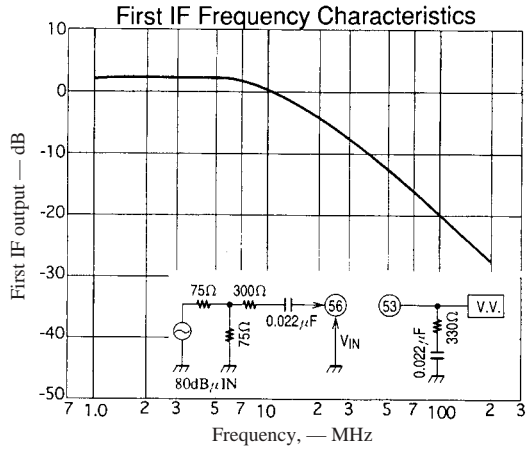

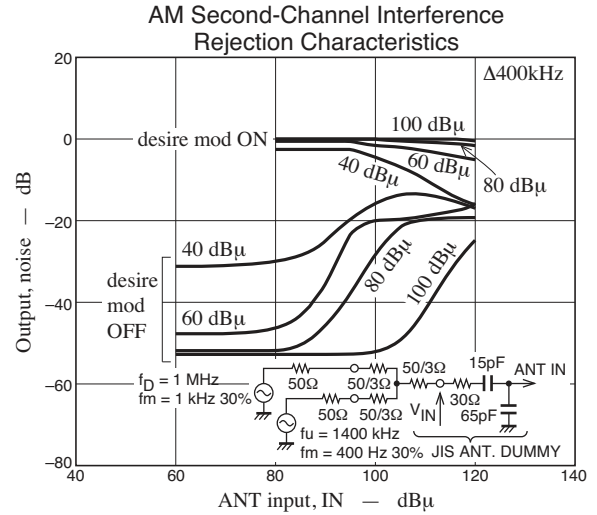
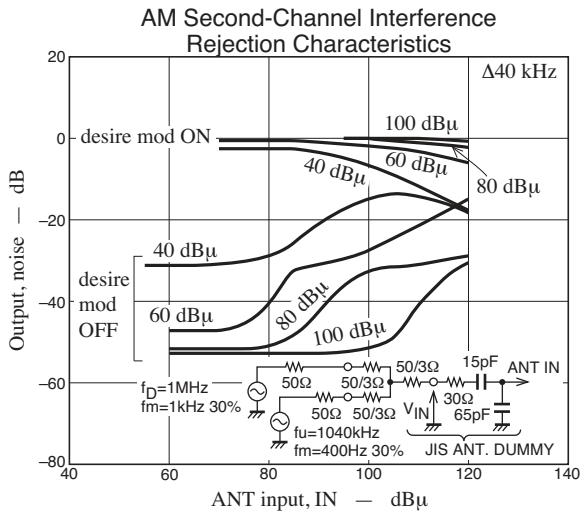

ON Semiconductor and the ON logo are registered trademarks of Semiconductor Components Industries, LLC (SCILLC). SCILLC owns the rights to a number of patents, trademarks, copyrights, trade secrets, and other intellectual property. A listing of SCILLC's product/patent coverage may be accessed at [www.onsemi.com/site/pdf/Patent-Marking.pdf](http://www.onsemi.com/site/pdf/Patent-Marking.pdf). SCILLC reserves the right to make changes without further notice to any products herein. SCILLC makes no warranty, representation or guarantee regarding the suitability of its products for any particular purpose, nor does SCILLC assume any liability arising out of the application or use of any product or circuit, and specifically disclaims any and all liability, including without limitation special, consequential or incidental damages. "Typical" parameters which may be provided in SCILLC data sheets and/or specifications can and do vary in different applications and actual performance may vary over time. All operating parameters, including "Typicals" must be validated for each customer application by customer's technical experts. SCILLC does not convey any license under its patent rights nor the rights of others. SCILLC products are not designed, intended, or authorized for use as components in systems intended for surgical implant into the body, or other applications intended to support or sustain life, or for any other application in which the failure of the SCILLC product could create a situation where personal injury or death may occur. Should Buyer purchase or use SCILLC products for any such unintended or unauthorized application, Buyer shall indemnify and hold SCILLC and its officers, employees, subsidiaries, affiliates, and distributors harmless against all claims, costs, damages, and expenses, and reasonable attorney fees arising out of, directly or indirectly, any claim of personal injury or death associated with such unintended or unauthorized use, even if such claim alleges that SCILLC was negligent regarding the design or manufacture of the part. SCILLC is an Equal Opportunity/Affirmative Action Employer. This literature is subject to all applicable copyright laws and is not for resale in any manner.