

54AC521 • 54ACT521 8-Bit Identity Comparator

General Description

The AC/ACT521 is an expandable 8-bit comparator. It compares two words of up to eight bits each and provides a LOW output when the two words match bit for bit. The expansion input $\bar{T}_{A=B}$ also serves as an active LOW enable input.

Features

- I_{CC} reduced by 50%
- Compares two 8-bit words in 6.5 ns typ
- Expandable to any word length
- Outputs source/sink 24 mA
- ACT521 has TTL-compatible inputs
- Standard microcircuit Drawing (SMD)
54AC521: 5962-90985
54ACT521: 5962-89793

Logic Symbols

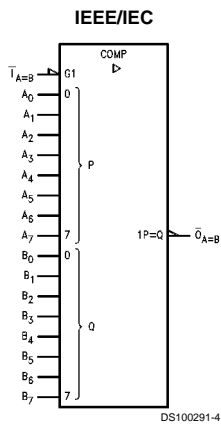
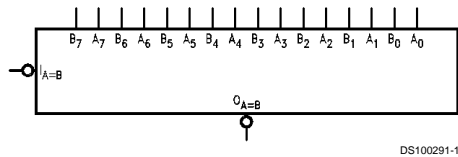

Connection Diagram

Pin Assignment for DIP and CERPACK

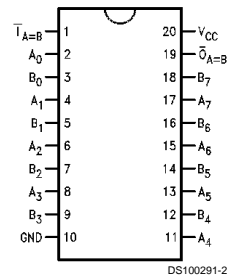

Pin Assignment for LCC

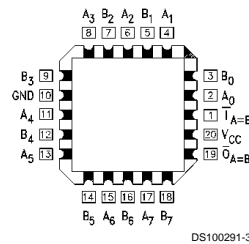

Pin Descriptions

Pin Names	Description
A ₀ -A ₇	Word A Inputs
B ₀ -B ₇	Word B Inputs
T _{A=B}	Expansion or Enable Input
O _{A=B}	Identity Output

Truth Table

Inputs		Outputs
$\bar{I}_{A=B}$	A, B	$\bar{O}_{A=B}$
L	A = B (Note 1)	L
L	A \neq B	H
H	A = B (Note 1)	H
H	A \neq B	H

H = HIGH Voltage Level
L = LOW Voltage Level

Note 1: $A_0 = B_0, A_1 = B_1, A_2 = B_2$, etc.

Logic Diagram

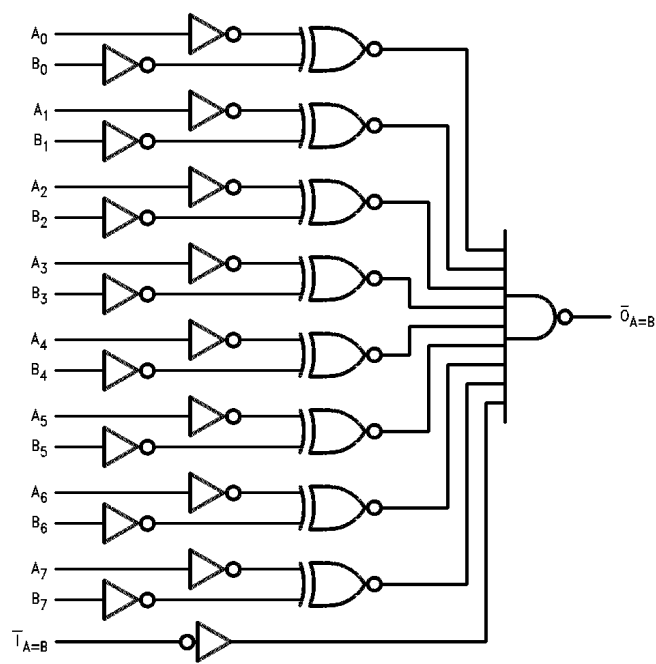

DS100291-5

Please note that this diagram is provided only for the understanding of logic operations and should not be used to estimate propagation delays.

Absolute Maximum Ratings (Note 2)

If Military/Aerospace specified devices are required, please contact the National Semiconductor Sales Office/Distributors for availability and specifications.

Supply Voltage (V_{CC})	-0.5V to +7.0V
DC Input Diode Current (I_{IK})	
$V_I = -0.5V$	-20 mA
$V_I = V_{CC} + 0.5V$	+20 mA
DC Input Voltage (V_I)	-0.5V to $V_{CC} + 0.5V$
DC Output Diode Current (I_{OK})	
$V_O = -0.5V$	-20 mA
$V_O = V_{CC} + 0.5V$	+20 mA
DC Output Voltage (V_O)	-0.5V to $V_{CC} + 0.5V$
DC Output Source or Sink Current (I_O)	±50 mA
DC V_{CC} or Ground Current per Output Pin (I_{CC} or I_{GND})	±50 mA
Storage Temperature (T_{STG})	-65°C to +150°C
Junction Temperature (T_J)	
CDIP	175°C

Recommended Operating Conditions

Supply Voltage (V_{CC})	
AC	2.0V to 6.0V
ACT	4.5V to 5.5V
Input Voltage (V_I)	0V to V_{CC}
Output Voltage (V_O)	0V to V_{CC}
Operating Temperature (T_A)	
54AC/ACT	-55°C to +125°C
Minimum Input Edge Rate ($\Delta V/\Delta t$)	
AC Devices	
V_{IN} from 30% to 70% of V_{CC}	
V_{CC} @ 3.3V, 4.5V, 5.5V	125 mV/ns
ACT Devices	
V_{IN} from 0.8V to 2.0V	
V_{CC} @ 4.5V, 5.5V	125 mV/ns

Note 2: Absolute maximum ratings are those values beyond which damage to the device may occur. The databook specifications should be met, without exception, to ensure that the system design is reliable over its power supply, temperature, output/input loading variables. Fairchild does not recommend operation of FACT™ circuits outside databook specifications.

DC Electrical Characteristics for AC

Symbol	Parameter	V_{CC} (V)	$T_A = -55^\circ\text{C to } +125^\circ\text{C}$		Units	Conditions	
			Guaranteed Limits				
V_{IH}	Minimum High Level Input Voltage	3.0	2.1		V	$V_{OUT} = 0.1V$ or $V_{CC} - 0.1V$	
		4.5	3.15				
		5.5	3.85				
V_{IL}	Maximum Low Level Input Voltage	3.0	0.9		V	$V_{OUT} = 0.1V$ or $V_{CC} - 0.1V$	
		4.5	1.35				
		5.5	1.65				
V_{OH}	Minimum High Level Output Voltage	3.0	2.9		V	$I_{OUT} = -50 \mu A$	
		4.5	4.4				
		5.5	5.4				
			3.0	2.4		V	$V_{IN} = V_{IL}$ or V_{IH} $I_{OH} = -4 \text{ mA}$ $I_{OH} = -24 \text{ mA}$ $I_{OH} = -24 \text{ mA (Note 3)}$
			4.5	3.7			
		5.5	4.7				
V_{OL}	Maximum Low Level Output Voltage	3.0	0.1		V	$I_{OUT} = 50 \mu A$	
		4.5	0.1				
		5.5	0.1				
			3.0	0.4		V	$V_{IN} = V_{IL}$ or V_{IH} $I_{OL} = 12 \text{ mA}$ $I_{OL} = 24 \text{ mA}$ $I_{OL} = 24 \text{ mA (Note 3)}$
			4.5	0.5			
		5.5	0.5				
I_{IN} (Note 5)	Maximum Input Leakage Current	5.5	±1.0		μA	$V_I = V_{CC}, GND$	
I_{OLD}	Minimum Dynamic Output Current (Note 4)	5.5	50		mA	$V_{OLD} = 1.65V \text{ Max}$	
I_{OHD}		5.5	-50		mA	$V_{OHD} = 3.85V \text{ Min}$	
I_{CC} (Note 5)	Maximum Quiescent Supply Current	5.5	80.0		μA	$V_{IN} = V_{CC}$ or GND	

Note 3: All outputs loaded; thresholds on input associated with output under test.

Note 4: Maximum test duration 2.0 ms, one output loaded at a time.

Note 5: I_{IN} and I_{CC} @ 3.0V are guaranteed to be less than or equal to the respective limit @ 5.5V V_{CC} .

DC Electrical Characteristics for ACT

Symbol	Parameter	V _{CC} (V)	T _A = -55°C to +125°C		Units	Conditions	
			Guaranteed Limits				
V _{IH}	Minimum High Level Input Voltage	4.5	2.0		V	V _{OUT} = 0.1V or V _{CC} - 0.1V	
		5.5	2.0				
V _{IL}	Maximum Low Level Input Voltage	4.5	0.8		V	V _{OUT} = 0.1V or V _{CC} - 0.1V	
		5.5	0.8				
V _{OH}	Minimum High Level Output Voltage	4.5	4.4		V	I _{OUT} = -50 μA	
		5.5	5.4				
			4.5	3.7		V	V _{IN} = V _{IL} or V _{IH} I _{OH} = -24 mA I _{OH} = -24 mA (Note 6)
			5.5	4.7			
V _{OL}	Maximum Low Level Output Voltage	4.5	0.1		V	I _{OUT} = 50 μA	
		5.5	0.1				
				4.5	0.5		V
5.5	0.5						
I _{IN}	Maximum Input Leakage Current	5.5	±1.0		μA	V _I = V _{CC} , GND	
I _{CC} T	Maximum I _{CC} /Input	5.5	1.5		mA	V _I = V _{CC} - 2.1V	
I _{OLD}	Minimum Dynamic Output Current (Note 7)	5.5	50		mA	V _{OLD} = 1.65V Max	
I _{OHD}		5.5	-50		mA	V _{OHD} = 3.85V Min	
I _{CC}	Maximum Quiescent Supply Current	5.5	80.0		μA	V _{IN} = V _{CC} or GND	

Note 6: All outputs loaded; thresholds on input associated with output under test.

Note 7: Maximum test duration 2.0 ms, one output loaded at a time.

AC Electrical Characteristics for AC

Symbol	Parameter	V _{CC} (V) (Note 8)	T _A = -55°C to +125°C C _L = 50 pF		Units
			Min	Max	
t _{PLH}	Propagation Delay A _n or B _n to $\overline{O}_{A=B}$	3.3	1.0	15.0	ns
		5.0	1.0	11.0	
t _{PHL}	Propagation Delay A _n or B _n to $\overline{O}_{A=B}$	3.3	1.0	10.5	ns
		5.0	1.0	8.0	
t _{PLH}	Propagation Delay $\overline{I}_{A=B}$ to $\overline{O}_{A=B}$	3.3	1.0	15.0	ns
		5.0	1.0	11.0	
t _{PHL}	Propagation Delay $\overline{I}_{A=B}$ to $\overline{O}_{A=B}$	3.3	1.0	10.5	ns
		5.0	1.0	8.0	

Note 8: Voltage Range 3.3 is 3.3V ±0.3V

Voltage Range 5.0 is 5.0V ±0.5V

AC Electrical Characteristics for ACT

Symbol	Parameter	V _{CC} (V) (Note 9)	T _A = -55°C to +125°C C _L = 50 pF		Units
			Min	Max	
t _{PLH}	Propagation Delay A _n or B _n to $\overline{O}_{A=B}$	5.0	1.5	11.0	ns
t _{PHL}	Propagation Delay A _n or B _n to $\overline{O}_{A=B}$	5.0	1.5	12.0	ns
t _{PLH}	Propagation Delay $\overline{I}_{A=B}$ to $\overline{O}_{A=B}$	5.0	1.5	7.5	ns
t _{PHL}	Propagation Delay $\overline{I}_{A=B}$ to $\overline{O}_{A=B}$	5.0	1.5	8.5	ns

Note 9: Voltage Range 5.0 is 5.0V ±0.5V

Capacitance

Symbol	Parameter	Typ	Units	Conditions
C _{IN}	Input Capacitance	4.5	pF	V _{CC} = OPEN
C _{PD}	Power Dissipation Capacitance	40	pF	V _{CC} = 5.0V

Applications

Ripple Expansion

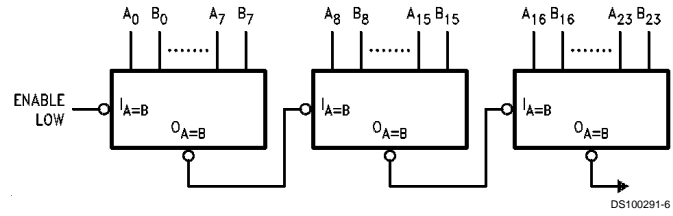

Parallel Expansion

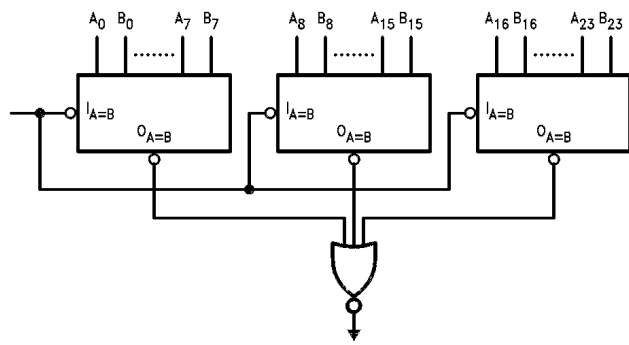



Physical Dimensions inches (millimeters) unless otherwise noted

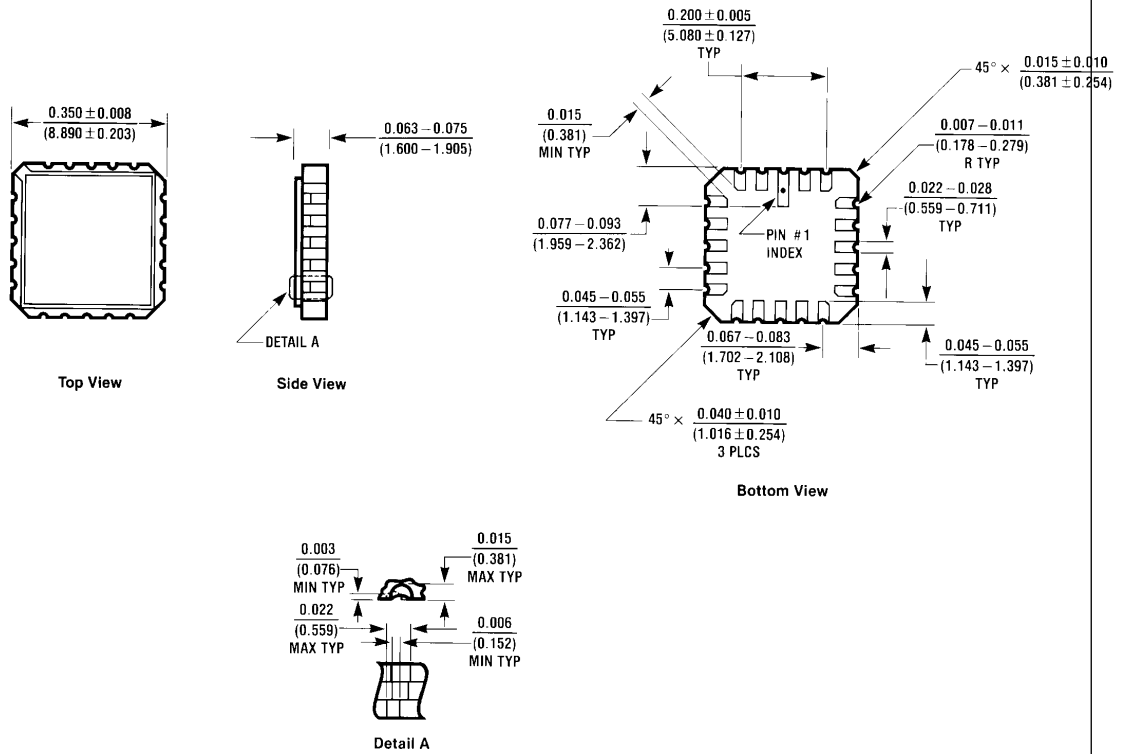

**20-Lead Ceramic Leadless Chip Carrier
Package Number E20A**

E20A (REV D)

Physical Dimensions inches (millimeters) unless otherwise noted (Continued)

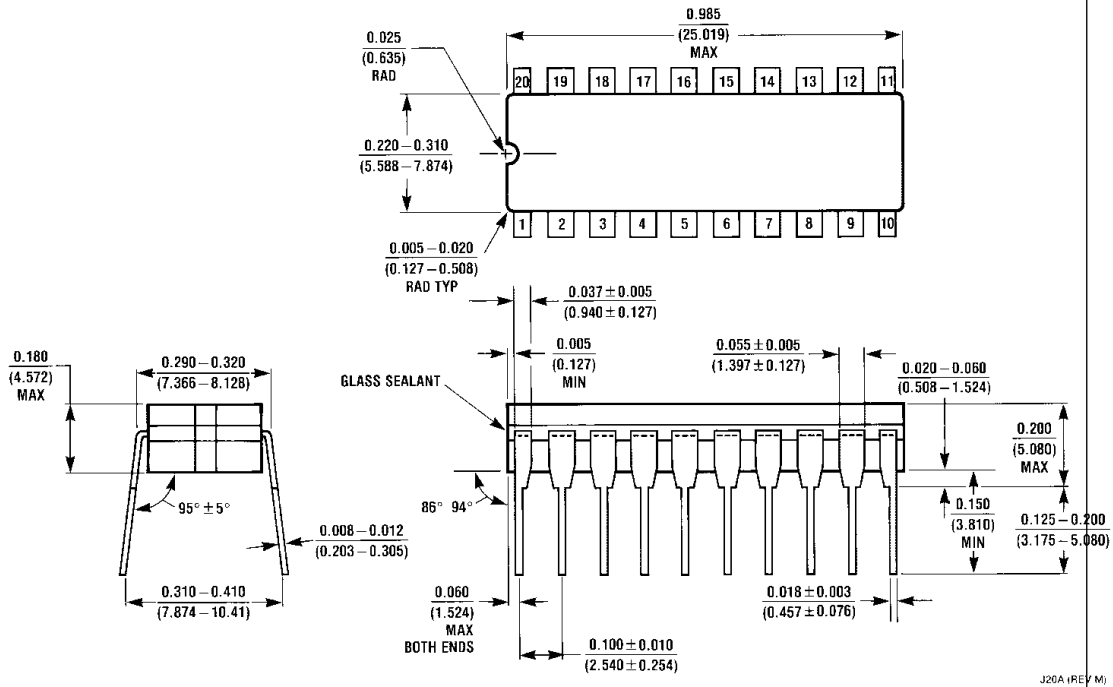

**20-Lead Ceramic Dual-in-line
J20A**

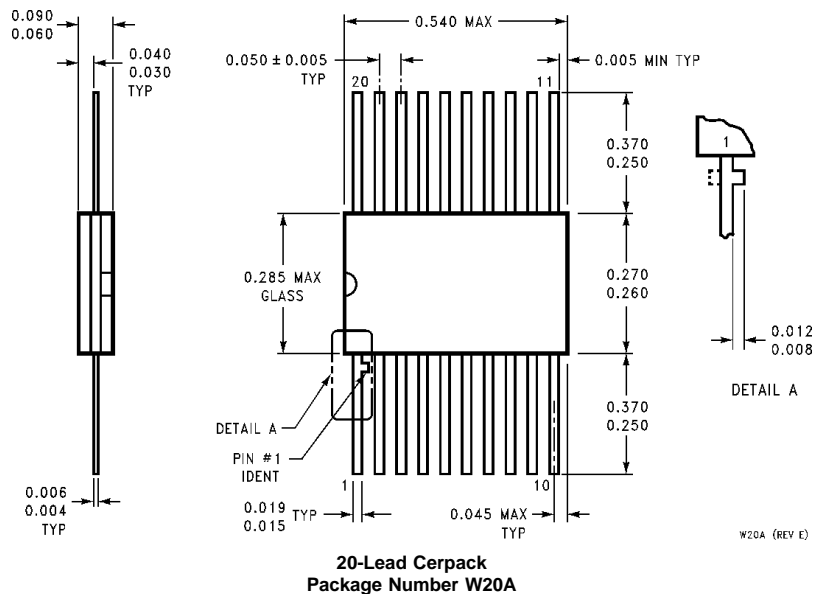

**20-Lead Cerpack
Package Number W20A**

LIFE SUPPORT POLICY

NATIONAL'S PRODUCTS ARE NOT AUTHORIZED FOR USE AS CRITICAL COMPONENTS IN LIFE SUPPORT DEVICES OR SYSTEMS WITHOUT THE EXPRESS WRITTEN APPROVAL OF THE PRESIDENT OF NATIONAL SEMICONDUCTOR CORPORATION. As used herein:

1. Life support devices or systems are devices or systems which, (a) are intended for surgical implant into the body, or (b) support or sustain life, and whose failure to perform when properly used in accordance with instructions for use provided in the labeling, can be reasonably expected to result in a significant injury to the user.
2. A critical component in any component of a life support device or system whose failure to perform can be reasonably expected to cause the failure of the life support device or system, or to affect its safety or effectiveness.



National Semiconductor Corporation
Americas
Tel: 1-800-272-9959
Fax: 1-800-737-7018
Email: support@nsc.com

www.national.com

National Semiconductor Europe
Fax: +49 (0) 1 80-530 85 86
Email: europe.support@nsc.com
Deutsch Tel: +49 (0) 1 80-530 85 85
English Tel: +49 (0) 1 80-532 78 32
Français Tel: +49 (0) 1 80-532 93 58
Italiano Tel: +49 (0) 1 80-534 16 80

National Semiconductor Asia Pacific Customer Response Group
Tel: 65-2544466
Fax: 65-2504466
Email: sea.support@nsc.com

National Semiconductor Japan Ltd.
Tel: 81-3-5620-6175
Fax: 81-3-5620-6179