

- THIS CONNECTOR ASSEMBLY IS SUPPLIED WITH METAL CONTACT RETENTION CLIPS INSTALLED IN THE INSERT ASSEMBLY.
- THIS CONNECTOR ASSEMBLY MEETS THE REQUIREMENTS OF LORAL SPEC 010772 AND MATES WITH ANY PLUG CONNECTOR WITH SAME INSERT ARRANGEMENT.
- MARK WITH .047 [1.19]-.062 [1.57] HIGH CHARACTERS. FAR SIDE REFERS TO THE WIDE SIDE OF THE KEYSTONE. NEAR SIDE REFERS TO THE NARROW SIDE OF THE KEYSTONE. IF THE REAR SHELL IS TOO SMALL FOR THE ENTIRE CUSTOMER PART NUMBER, MARKING SHALL BE LOCATED AS FOLLOWS:
 - CUSTOMER BASE NUMBER, ON FRONT SHELL, FAR SIDE.
 - CUSTOMER DASH NUMBER ON REAR SHELL, FAR SIDE.
 - "AMP" AND DATE CODE ON FRONT SHELL, NEAR SIDE.
 - AMP PART NUMBER ON REAR SHELL, NEAR SIDE.
- POINT OF ELECTRICAL ENGAGEMENT - AS MEASURED WITH A .039 [0.99] - .041 [1.04] DIAMETER SQUARE ENDED TEST PIN. CONTACT SHOWN INSTALLED FOR DIMENSIONAL REFERENCE ONLY.
- MAXIMUM WIRE INSULATION TO BE USED WITH THIS CONNECTOR ASSEMBLY IS .072 [1.83] DIAMETER.
- FOR CONTACT CRIMPING INSTRUCTION SHEET REFER TO AMP IS 7516. FOR CONTACT INSTALLATION AND REMOVAL INSTRUCTION SHEET REFER TO AMP IS 7508.
- DIMENSIONS AND TOLERANCES PER ANSI Y14.5M-1982.
- THIS DRAWING SHALL BE INTERPRETED IN ACCORDANCE WITH APPLICABLE STANDARDS LISTED IN MIL-STD-100.

PRELIMINARY-NOT RELEASED FOR PRODUCTION	.040 [1.02] .020 [0.51]	.432 [10.97] .412 [10.46]	1.093 [27.76] 1.073 [27.25]	.248 [6.30] .238 [6.05]	.439 [11.15] .419 [10.64]	.509 [12.93] .479 [12.17]	.316 [8.03] .306 [7.77]	1.317 [33.45] 1.307 [33.20]	.976 [24.79] .966 [24.54]	1.556 [39.52] 1.526 [38.76]	MS18274-1	15	2	B010772-0043	3-448816-2	3-448816-2
PRELIMINARY-NOT RELEASED FOR PRODUCTION	.049 [1.24] .029 [0.74]	.544 [13.82] .524 [13.31]	2.188 [55.58] 2.168 [55.07]			.620 [15.75] .590 [14.99]	.428 [10.87] .418 [10.62]	2.411 [61.24] 2.401 [60.99]	2.069 [52.55] 2.059 [52.30]	2.650 [67.31] 2.620 [66.55]	MS18277-1	50	5	B010772-0032	1-448816-5	1-448816-5
PRELIMINARY-NOT RELEASED FOR PRODUCTION			2.282 [57.96] 2.262 [57.45]	.248 [6.30] .238 [6.05]	.439 [11.15] .419 [10.64]			2.505 [63.63] 2.495 [63.37]	2.164 [54.97] 2.154 [54.71]	2.744 [69.70] 2.714 [68.94]	MS18276-1	37	4	B010772-0030	1-448816-4	1-448816-4
PRELIMINARY-NOT RELEASED FOR PRODUCTION	.040 [1.02] .020 [0.51]	.432 [10.97] .412 [10.46]	1.635 [41.53] 1.615 [41.02]	.248 [6.30] .238 [6.05]	.439 [11.15] .419 [10.64]	.509 [12.93] .479 [12.17]	.316 [8.03] .306 [7.77]	1.857 [47.17] 1.847 [46.91]	1.516 [38.51] 1.506 [38.25]	2.103 [53.42] 2.073 [52.65]	MS18275-1	25	3	B010772-0028	1-448816-3	1-448816-3
PRELIMINARY-NOT RELEASED FOR PRODUCTION			1.093 [27.76] 1.073 [27.25]					1.317 [33.45] 1.307 [33.20]	.976 [24.79] .966 [24.54]	1.556 [39.52] 1.526 [38.76]	MS18274-1	15	2	B010772-0026	1-448816-2	1-448816-2
			.769 [19.53] .749 [19.02]					.989 [25.12] .979 [24.87]	.648 [16.46] .638 [16.21]	1.228 [31.19] 1.198 [30.43]	MS18273-1	9	1	B010772-0024	1-448816-1	1-448816-1
	.049 [1.24] .029 [0.74]	.544 [13.82] .524 [13.31]	2.188 [55.58] 2.168 [55.07]			.620 [15.75] .590 [14.99]	.428 [10.87] .418 [10.62]	2.411 [61.24] 2.401 [60.99]	2.069 [52.55] 2.059 [52.30]	2.650 [67.31] 2.620 [66.55]	MS18277-1	50	5	A010772-0010	1-448816-0	1-448816-0
			2.282 [57.96] 2.262 [57.45]	.248 [6.30] .238 [6.05]	.439 [11.15] .419 [10.64]			2.505 [63.63] 2.495 [63.37]	2.164 [54.97] 2.154 [54.71]	2.744 [69.70] 2.714 [68.94]	MS18276-1	37	4	A010772-0008	448816-9	448816-9
		.432 [10.97] .412 [10.46]	1.635 [41.53] 1.615 [41.02]	.248 [6.30] .238 [6.05]	.439 [11.15] .419 [10.64]	.509 [12.93] .479 [12.17]	.316 [8.03] .306 [7.77]	1.857 [47.17] 1.847 [46.91]	1.516 [38.51] 1.506 [38.25]	2.103 [53.42] 2.073 [52.65]	MS18275-1	25	3	A010772-0006	448816-8	448816-8
	.040 [1.02] .020 [0.51]		1.093 [27.76] 1.073 [27.25]					1.317 [33.45] 1.307 [33.20]	.976 [24.79] .966 [24.54]	1.556 [39.52] 1.526 [38.76]	MS18274-1	15	2	A010772-0004	448816-7	448816-7
			.769 [19.53] .749 [19.02]					.989 [25.12] .979 [24.87]	.648 [16.46] .638 [16.21]	1.228 [31.19] 1.198 [30.43]	MS18273-1	9	1	A010772-0002	448816-6	448816-6
	.049 [1.24] .029 [0.74]	.544 [13.82] .524 [13.31]	2.188 [55.58] 2.168 [55.07]			.620 [15.75] .590 [14.99]	.428 [10.87] .418 [10.62]	2.411 [61.24] 2.401 [60.99]	2.069 [52.55] 2.059 [52.30]	2.650 [67.31] 2.620 [66.55]	MS18277-1	50	5	B010772-0010	448816-5	448816-5
			2.282 [57.96] 2.262 [57.45]	.248 [6.30] .238 [6.05]	.439 [11.15] .419 [10.64]			2.505 [63.63] 2.495 [63.37]	2.164 [54.97] 2.154 [54.71]	2.744 [69.70] 2.714 [68.94]	MS18276-1	37	4	B010772-0008	448816-4	448816-4
		.432 [10.97] .412 [10.46]	1.635 [41.53] 1.615 [41.02]	.248 [6.30] .238 [6.05]	.439 [11.15] .419 [10.64]	.509 [12.93] .479 [12.17]	.316 [8.03] .306 [7.77]	1.857 [47.17] 1.847 [46.91]	1.516 [38.51] 1.506 [38.25]	2.103 [53.42] 2.073 [52.65]	MS18275-1	25	3	B010772-0006	448816-3	448816-3
	.040 [1.02] .020 [0.51]		1.093 [27.76] 1.073 [27.25]					1.317 [33.45] 1.307 [33.20]	.976 [24.79] .966 [24.54]	1.556 [39.52] 1.526 [38.76]	MS18274-1	15	2	B010772-0004	448816-2	448816-2
			.769 [19.53] .749 [19.02]					.989 [25.12] .979 [24.87]	.648 [16.46] .638 [16.21]	1.228 [31.19] 1.198 [30.43]	MS18273-1	9	1	B010772-0002	448816-1	448816-1
L	J	H	G	F	E	D	C	B	A		INSERT ARRANGEMENT	NO OF POS	SHELL SIZE	CUSTOMER P/N ON CONNECTOR	AMP P/N ON CONNECTOR	PART NUMBER

THIS DRAWING IS A CONTROLLED DOCUMENT.

DIMENSIONS: INCHES	TOLERANCES UNLESS OTHERWISE SPECIFIED:	0 PLC ± .005	1 PLC ± .005	2 PLC ± .005	3 PLC ± .005	4 PLC ± .005	ANGLES ± .1°
--------------------	--	--------------	--------------	--------------	--------------	--------------	--------------

MATERIAL: SEE CALLOUTS. FINISH: SEE CALLOUTS.

REV	BY	DATE	DESCRIPTION
1	AJ GRAFF	2-11-93	
2	FK KINSEY	2-17-93	
3	FK KINSEY	2-17-93	

APPROVED: F. KINSEY

NAME: AMPLITE NONMAGNETIC RECEPTACLE ASSY WITH SIZE 20 CRIMP TYPE SOCKET CONTACTS SERIES 109, SHELL SIZES 1 THRU 5

SIZE: A1. CASE CODE: 00779. DRAWING NO: 448816. RESTRICTED TO: CUSTOMER DRAWING. SCALE: 4:1. SHEET: 1 OF 2. REV: E.

LOC		DIST		REVISIONS			
P	LYR	DESCRIPTION	DATE	DNW	APVD		
-	-	SEE SHEET 1	-	-	-	-	-

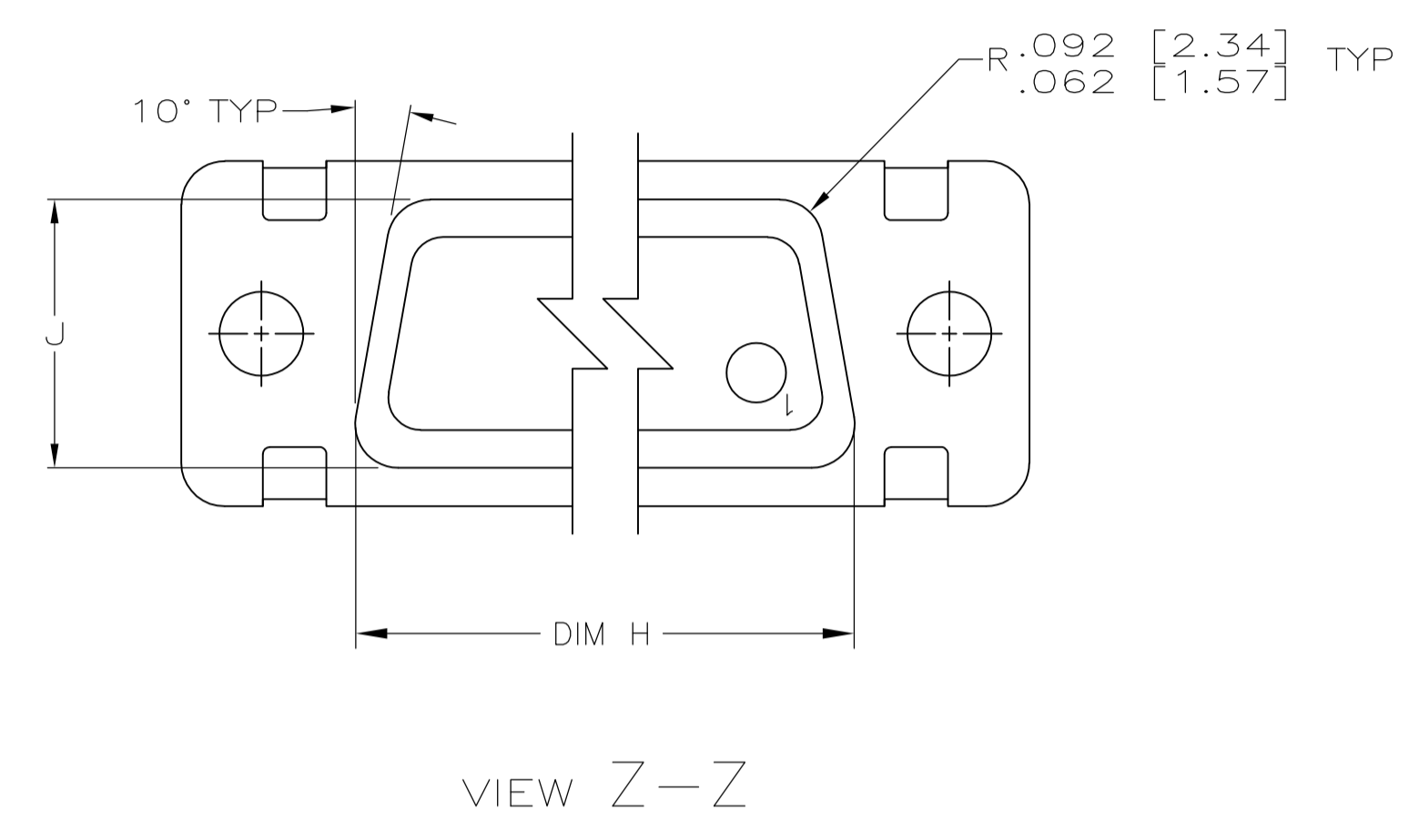
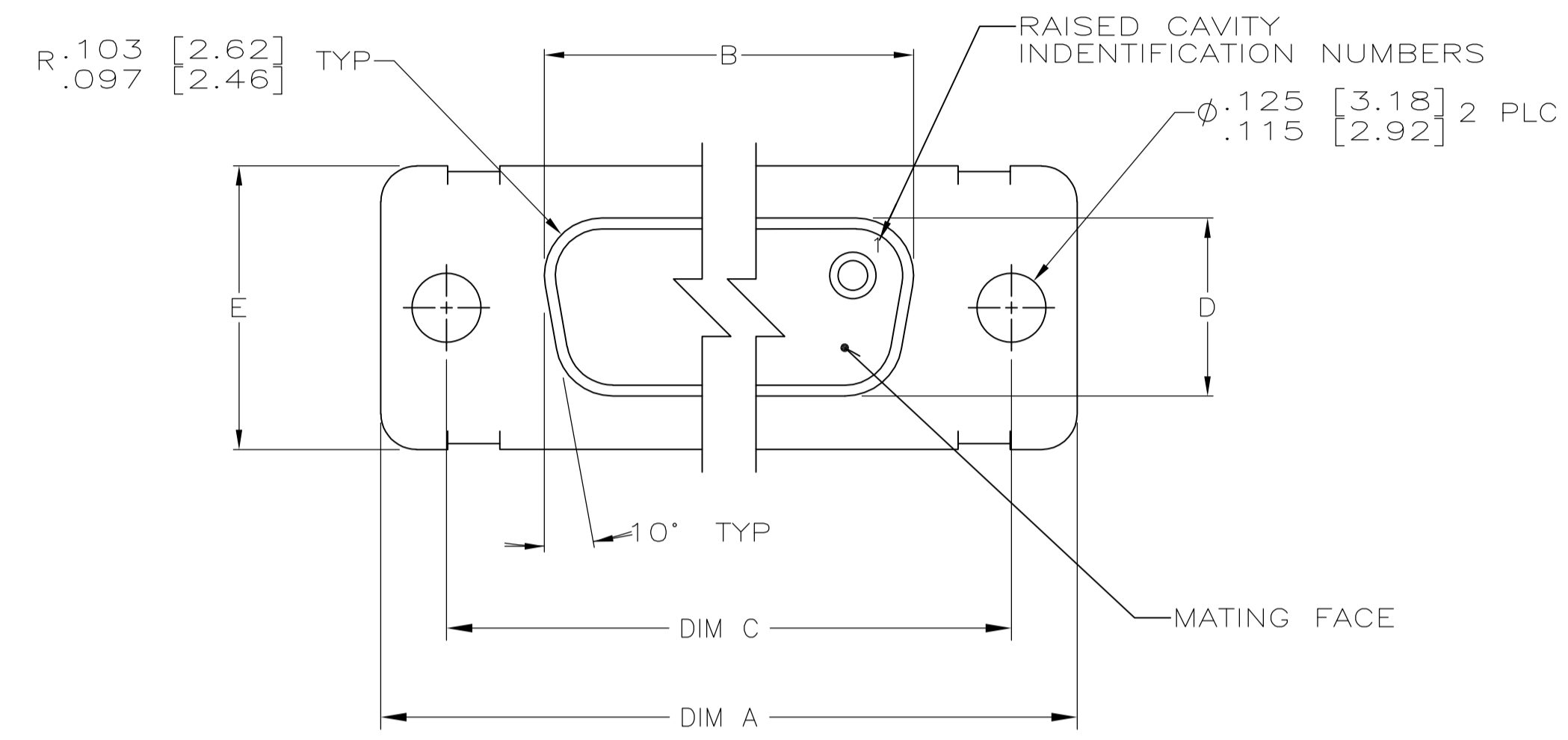

3 MARK AMP, AMP PART NO AND DATE CODE, FAR SIDE.

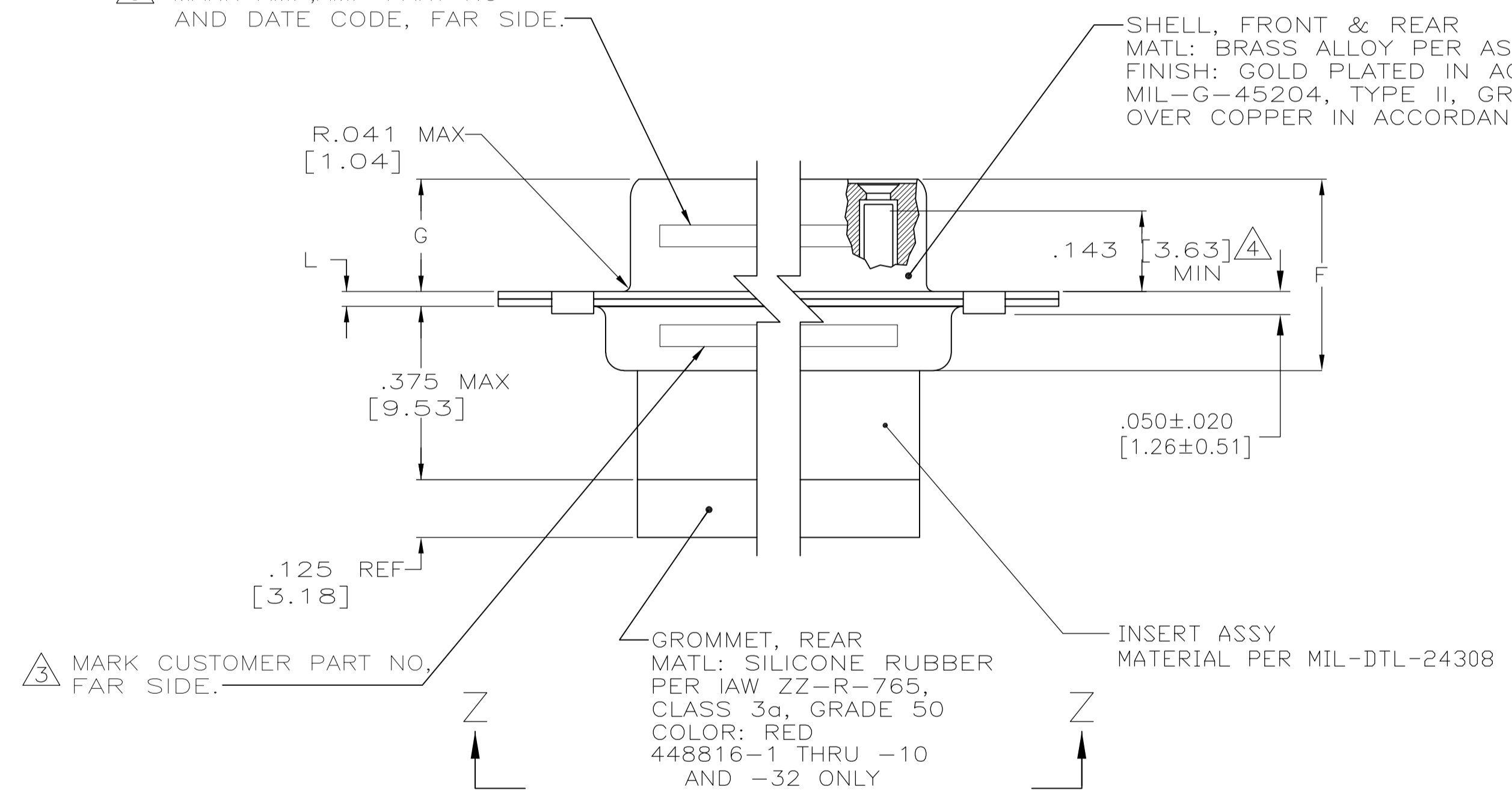

3 MARK CUSTOMER PART NO, FAR SIDE.

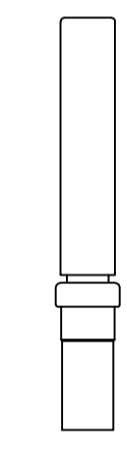

CONTACT
 AMP P/N 206793-1 (AWG 20-24)
 OR 206795-1 (AWG 26-28)

THIS DRAWING IS A CONTROLLED DOCUMENT.		DIN AJ GRAFF 2-11-93	STE TE Connectivity	
DIMENSIONS: INCHES		CHK F. KINSEY 2-17-93	NAME	
TOLERANCES UNLESS OTHERWISE SPECIFIED:		APVD	PRODUCT SPEC	
0 PLC ± -		MIL-C-24308		
1 PLC ± -		APPLICATION SPEC		
2 PLC ± -		SIZE	CAGE CODE	DRAWING NO
3 PLC ± -		—	—	—
4 PLC ± -		WEIGHT	RESTRICTED TO	
ANGLES ± ±		—	—	
MATERIAL SEE CALLOUTS	FINISH SEE CALLOUTS	A1 00779 C=448816		
CUSTOMER DRAWING		SCALE	SHEET	REV
		4:1	2 OF 2	E